

\$2.00

ham radio

magazine

hr 

NOVEMBER 1980

- four-band super quad 12
- stacking Yagi antennas 22
- crystal use locator 36
- simple CW memory 46
- 13th HW-2036 update 50

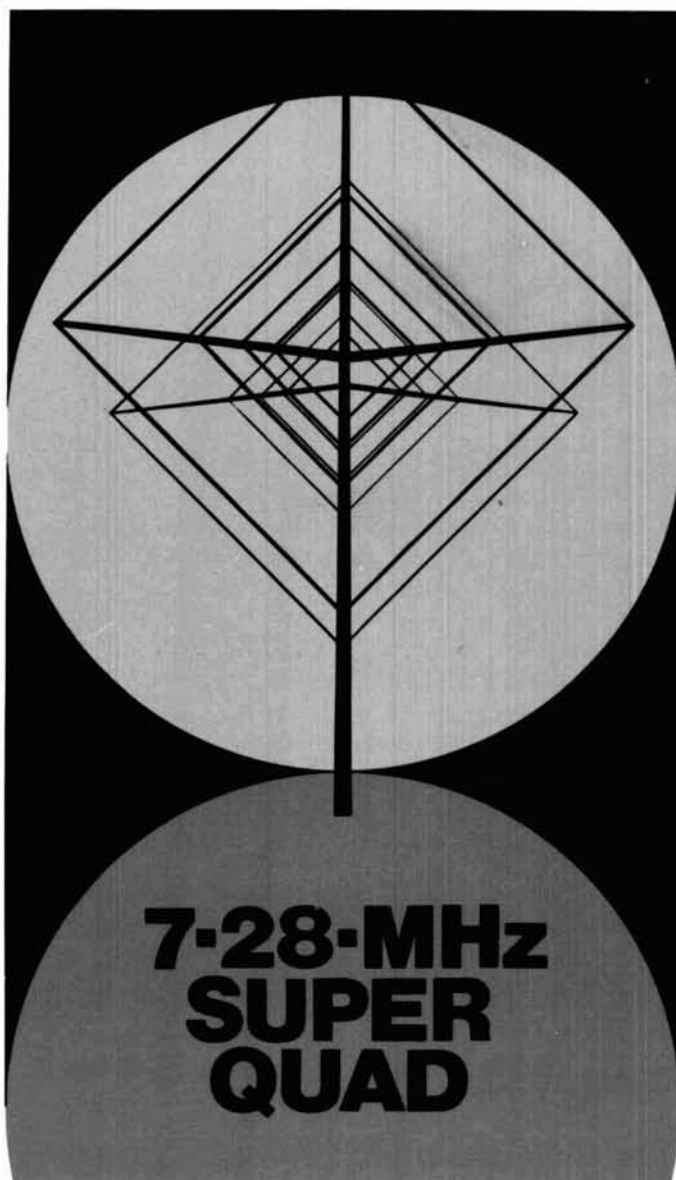



Shown with optional touch tone pad

tempo...

the first in synthesized portables gives you the broadest choice at the lowest price

...the new S-5

- * The only synthesized hand-held offering 5 watt output. (Switchable for 1 or 5 watt operation)
- * The same dependability as the time proven S-1 Circuitry that has been proven in more than a million hours of operation.
- * Heavy duty battery pack.
- * External microphone capability.
- * The S-5's exciting low price...only \$299.00
- * With touch tone pad \$339.00

The new improved Tempo S-1

- The first and most thoroughly field tested hand-held synthesized radio available. 800 channels in the palm of your hand.
- Simple to operate. (You don't need a degree in computer programming)
- Heavy duty battery pack allows more operating time between charges.
- External microphone capability
- The lowest price ever...\$259.00
- The S-1T (With touch tone pad installed)...\$289.00

Now available is the expanded line of Tempo commercial hand helds... "big name" quality at affordable prices. The FMH-12 & FMH-15 operate in the 135 to 174 MHz range and the FMH-40 & FMH-44 in the 440 to 480 MHz range. Tempo also offers the FMT-2 & FMT-42. They provide excellent VHF or UHF mobile communications and feature a remote control head for hide-away mounting. Also available is the superb MR-3 pocket receiver... a miniature, 2 channel VHF high band monitor or paging receiver.

Please call or write for complete information. Also available from Tempo dealers throughout the U.S. and abroad.

SPECIFICATIONS

Frequency Coverage: 144 to 148 MHz
 Channel Spacing: Receive every 5 kHz, transmit Simplex or ± 600 kHz
 Power Requirements: 9.6 VDC
 Current Drain: 17 ma-standby, 900 ma-transmit
 Antenna Impedance: 50 ohms
 Dimensions: 40 mm x 62 mm x 170 mm (1.6" x 2.5" x 6.7")
 Weight: 17 oz.
 Sensitivity: Better than .5 microvolts nominal for 20 db

SUPPLIED ACCESSORIES

Telescoping whip antenna, ni-cad battery pack, charger.

OPTIONAL ACCESSORIES

12 Button touch tone pad (not installed): \$39 • 16 Button touch tone pad (not installed): \$48 • Tone burst generator: \$29.95 • CTCSS sub-audible tone control: \$29.95 • Rubber flex antenna: \$8 • Leather holster: \$16 • Cigarette lighter plug mobile charging unit: \$6 • Matching 30 watt output 13.8 VDC power amplifier (S30): \$89 • Matching 80 watt output power amplifier (S80): \$149

The Tempo S-2

Tempo is first again. This time with a superior quality synthesized 220 MHz hand held transceiver. With an S-2 in your car or pocket you can use 220 MHz repeater throughout the U.S. It offers all the advanced engineering, premium quality components and exciting features of the S-1. The S-2 offers 1000 channels in an extremely lightweight but rugged case.

If you're not on 220 this is the perfect way to get started. With the addition of the S-25 (25W output) or S-75 (75W output) Tempo solid state amplifier it becomes a powerful mobile or base station. If you have a 220 MHz rig, the S-2 will add tremendous versatility. Its low price includes an external microphone capability heavy duty ni-cad battery pack, charger, and telescoping whip antenna. Price...\$349.00 With touch tone pad...\$399.00

TEMPO VHF & UHF SOLID STATE POWER AMPLIFIERS

Boost your signal... give it the range and clarity of a high powered base station. VHF (135 to 175 MHz)

Drive Power	Output	Model No.	Price
2W	130W	130A02	\$209
10W	130W	130A10	\$189
30W	130W	130A30	\$199
2W	80W	80A02	\$169
10W	80W	80A10	\$149
30W	80W	80A30	\$159
2W	50W	50A02	\$129
2W	30W	30A02	\$ 89

UHF (400 to 512 MHz) models, lower power and FCC type accepted models also available.

TOLL FREE ORDER NUMBER: (800) 421-6631

For all states except California. Calif. residents please call collect on our regular numbers.

11240 W. Olympic Blvd., Los Angeles, Calif. 90064 213/477-6701
 931 N. Euclid, Anaheim, Calif. 92801 714/772-9200
 Butler, Missouri 64730 816/679-3127



Henry Radio

Prices subject to change without notice

Yesterday you could admire all-band digital tuning in a short wave receiver.* Today you can afford it.



RF-4900

Tune in the Panasonic Command Series™ top-of-the-line RF-4900. Everything you want in short wave at a surprisingly affordable price. Like fluorescent all-band readout with a five-digit

frequency display. It's so accurate (within 1 kHz, to be exact), you can tune in a station even before it's broadcasting. And with the RF-4900's eight short wave bands, you can choose any broadcast between 1.6 and 31 MHz. That's all short wave bands. That's Panasonic.

And what you see on the outside is just a small part of what Panasonic gives you inside. There's a double superheterodyne system for sharp reception stability and selectivity as well as image rejection. An input-tuned RF amplifier with a 3-ganged variable tuning capacitor for excellent sensitivity and frequency linearity. Ladder-type ceramic filters to reduce frequency interference. And even an antenna trimmer that changes the front-end capacitance for reception of weak broadcast signals.

To help you control all that sophisticated circuitry, Panasonic's RF-4900 gives you all these sophisticated controls. Like an all-gear-drive

tuning control to prevent "backlash." Separate wide/narrow bandwidth selectors for crisp reception even in crowded conditions. Adjustable calibration for easy tuning to exact frequencies. A BFO pitch control. RF-gain control for improved reception in strong signal areas. An ANL switch. Even separate bass and treble controls.

And if all that short wave isn't enough. There's more. Like SSB (single sideband) amateur radio. All 40 CB channels. Ship to shore. Even Morse communications. AC/DC operation. And with

Panasonic's 4" full-range speaker, the big sound of AM and FM will really sound big. There's also the Panasonic RF-2900. It has most of the features of the RF-4900, but it costs a lot less.

The Command Series from Panasonic. If you had short wave receivers as good. You wouldn't still be reading. You'd be listening.

*Short wave reception will vary with antenna, weather conditions, operator's geographic location and other factors. An outside antenna may be required for maximum short wave reception.



RF-2900

*Short wave reception will vary with antenna, weather conditions, operator's geographic location and other factors. An outside antenna may be required for maximum short wave reception.

Panasonic
just slightly ahead of our time.

MFJ 941C Versa Tuner II



MFJ-941C
\$84⁹⁵ (+\$4)

Fastest selling MFJ tuner . . . because it has the most wanted features at the best price.

SWR + dual range wattmeter (300 & 30 watts full scale, forward and reflected power). *Sensitive meter* measures SWR down to 5 watts output.

More flexible antenna switch selects 2 coax lines, direct or through tuner, random wire/balanced line, or tuner bypass for dummy load.

12 position efficient airwound inductor for lower losses, more watts out.

Built-in 4:1 balun for balanced lines. 1000v capacitor spacing.

Matches everything from 160-10 meters: dipoles, inverted vees, random wires, verticals, mobile whips, beams, balanced and coax lines.

Easy to use, anywhere. Measures 8x2x6", has SO-239 connectors, 5-way binding posts, finished in eggshell white with walnut-grained sides.

MFJ-945, \$74.95, like model 941C but less ant. switch. Optional mobile bracket for either model is \$3.

MFJ 484 "Grandmaster" Memory Keyer



MFJ-484
\$139⁹⁵ (+\$4)

Up to twelve 25 character messages plus 100, 75, 50 or 25 ch. messages (4096 bits). **Repeat any message continuously or with pauses** of up to 2 min. LEDs show use.

Record, playback, or change messages instantly at touch of a button. Memories are resettable with button or touch of the paddle.

Built-in memory saver — 9 V battery takes over when power is lost.

Iambic operation with squeeze key. Dot-dash insertion. Optional BENCHER paddle \$42.95 +\$4.

Dot-Dash memories, self-completing, jam-proof spacing, instant start.

Panel controls: Speed (8-50wpm)/Record; Weight/Memories Combined; Tone/Tune; Delay (0-2 min.)/Repeat; rotary Vol/On-Off; Memory Select; Message Buttons select desired 25 ch. messages; Memory Reset button.

Ultra reliable solid state keying: grid block, cathode, solid state transmitters (-300 V, 10 mA max; +300 V, 100 mA max). Operates 12-15 VDC or 110 VAC with optional adapter, \$7.95 +\$2. Size 8x2x6". **MFJ-482, \$99.95**, four 25 or 50+two 25 ch. messages; **MFJ-481, \$89.95**, two 50 ch. messages. **Get the best seller keyers-MFJ "Grandmasters."**

MFJ 410 "Professor Morse" Code Generator/Keyer



NEW LOW PRICE
Save \$20

MFJ-410 Now Only **\$129⁹⁵** (+\$4)

Use it to learn, use it to operate. It sends *unlimited random code* in random groups for practice; *never repeats* sequences. And when you're on the air, it's a *full feature keyer*.

Vary speed from 5-50 wpm; meter readout.

Vary spacing; give fast sound to low speed.

Alpha or alphanumeric with punctuation.

Built-in speaker and phone jack; tone and vol. Ideal for classroom or private use.

Full feature keyer includes vol., speed, tone and weight controls, tune switch, dot-dash memories, keys grid block, cathode, solid-state rigs. Optional BENCHER paddle \$42.95 +\$4. Operates on 9-18 VDC, two 9 V batteries or 110 VAC with optional adapter \$7.95 +\$2. Size 7x2x6". **Get "Professor Morse"** — you'll never outgrow it.

MFJ Dual Tunable SSB/CW Filter "Signal Enhancer"



MFJ-752B **\$84⁹⁵** (+\$4)

Dual filters give unmatched performance. **The primary filter** lets you *peak, notch, low pass or high pass* with extra steep skirts.

Auxiliary filter; 70 dB notch, 40 Hz peak.

Both filters tune from 300 to 3000 Hz with variable bandwidth from 40 Hz to nearly flat.

Constant output as bandwidth is varied; linear frequency control.

Switchable noise limiter for impulse noise.

Simulated stereo sound for CW lets ears and mind reject QRM.

Inputs for 2 rigs, switch selectable. Plugs into phone jack. Two watts for speaker. OFF bypasses filter. 9-18 VDC, 300 mA or 110 VAC with optional adapter \$7.95 +\$2. 10x2 x6". **MFJ 751, \$59.95**, similar, primary filter only, less high pass & noise limiter.

MFJ BEST SELLERS

favorite products from the world's leading manufacturer of amateur radio accessories

GMT Clock/ID Timer



MFJ-101
\$29⁹⁵ (+\$4)

24 hour, solid-state, blue 0.6" digits, ID timer sounds every 9 min (also a snooze alarm), regular alarm for skeds or to awaken, power-out/alarm-on indicators, ready to use on 110 VAC, 50-60Hz, 6x2x3".

KW Dummy Load With Oil



MFJ-250
\$29⁹⁵ (+\$4)

Rated at 1 kW CW or 2 kW PEP for 10 min., half that for 20 min., cont. at 200 W CW, 400 W PEP, non-inductive 50 ohm resistor, quality transformer oil (no PCB), VSWR under 1.2:1 to 30 MHz, 1.5:1, 30-300 MHz, 2:1, 300-400 MHz. Coax conn., vent cap., 7 1/2" h x 6 3/8" diam.

300 Watt Antenna Tuner



MFJ-949B
\$129⁹⁵ (+\$4)

Does it all! Built-in dummy load, SWR, forward and reflected power meter, antenna switch, balun, matches everything from 1.8-30 MHz (coax, random wires, balanced lines), coax conn., binding post, 10x3x7".

TO ORDER PRODUCTS, CALL TOLL FREE

800-647-1800

For tech. info., order or repair status, or calls outside continental U.S. and inside Miss., call 601-323-5869.

- All MFJ products unconditionally guaranteed for one year (except as noted)
- Products ordered from MFJ are returnable within 30 days for full refund (less shipping)
- Add shipping & handling charges in amounts shown in parentheses

Write for FREE catalog, over 60 products

MFJ ENTERPRISES INCORPORATED

Box 494; Mississippi State, MS 39762

ham radio

magazine

NOVEMBER 1980

volume 13, number 11

T. H. Tenney, Jr., W1NLB
publisher and
editor-in-chief

Alfred Wilson, W6NIF
editor

editorial staff

Martin Hanft, WB1CHQ
administrative editor

Robert Schneider, N6MR
assistant editor

Thomas F. McMullen, Jr., W1SL
Joseph J. Schroeder, W9JUV
Leonard H. Anderson
associate editors

W. E. Scarborough, Jr., KA1DXQ
graphic production manager

Irene Hollingsworth
editorial assistant

Catherine M. Umphress
production assistant

Wayne Pierce, K3SUK
cover

publishing staff

Peter M. Hurd, N1SS
assistant publisher

J. Craig Clark, Jr., N1ACH
advertising manager

Susan Shorrock
circulation manager

ham radio magazine
is published monthly by
Communications Technology, Inc
Greenville, New Hampshire 03048
Telephone: 603-878-1441

subscription rates

United States: one year, \$15.00
two years, \$26.00; three years, \$35.00

Canada and other countries (via Surface Mail)
one year, \$18.00; two years, \$32.00
three years, \$44.00

Europe, Japan, Africa (via Air
Forwarding Service) one year, \$25.00

All subscription orders payable in
United States funds, please

foreign subscription agents

Foreign subscription agents are
listed on page 83

Microfilm copies
are available from
University Microfilms, International
Ann Arbor, Michigan 48106
Order publication number 3076

Cassette tapes of selected articles
from ham radio are available to the
blind and physically handicapped
from Recorded Periodicals
919 Walnut Street, 8th Floor
Philadelphia, Pennsylvania 19107

Copyright 1980 by
Communications Technology, Inc
Title registered at U. S. Patent Office

Second-class postage
paid at Greenville, N. H. 03048
and at additional mailing offices
ISSN 0148-5989

Postmaster send Form 3679 to ham radio
Greenville, New Hampshire 03048



contents

12 super quad for 7-28 MHz

Frederick Hauff, W3NZ

18 automatic CQer for RTTY

Nathan H. Stinnette, W4AYV

22 Yagi antenna design: stacking

James L. Lawson, W2PV

36 crystal use locator

Phillips Hughes, WA6SWR

38 transmission-line circuit design

H. M. Meyer, Jr., W6GGV

46 simple CW memory

John R. Megirian, K4DHC

**50 updating the Heathkit HW-2036
for digital readout and scan**

Thomas A. French, WA4BZP

58 the XK2C AFSK generator

Robert W. Lewis, W3HVK

94 advertisers index

83 flea market

90 ham mart

68 ham notebook

6 letters

**4 observation and
opinion**

8 presstop

94 reader service

46 weekender

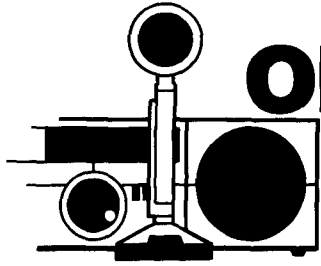

Observation & Opinion

A new book has come to our attention, a book interesting enough to merit mention in this column. The name of the book is *From Beverages Thru OSCAR — A Bibliography*, and the author is Rich Rosen, K2RR, of Littleton, Colorado.

From Beverages Thru OSCAR is not, as the name might imply, a bibliography of reference works dealing with Amateur antennas. It is instead a complete list of every article of interest to the Radio Amateur and professional published over the last 65 years in any of 288 electronics magazines and journals, including *CQ*, *ham radio*, *73*, and *QST*. The 30,000 articles referenced in this text are divided into 92 subject categories, to make locating any given article largely a matter of determining into which category it should fall. Catchy or cute article titles have been simplified and entered into their proper category. The subject categories include such headings as Preamps, Oscillators, Filters, SSB, Lasers, Alternative Power Sources, Receivers, and Antenna Hardware.

The value of such a reference text is immediately obvious. Having access to this bibliography makes it possible to track down that elusive article on signal enhancement, or rotators, or whatever — that article that you're sure you've read in some magazine or other, but you can't quite remember which magazine it was. Or whether you read the article while in the "Fathers' Suite" of the maternity ward waiting for Junior to be born or on the way to his high-school graduation. Or whether the article was in one of your regular subscription magazines or in one you leafed through at a flea market but decided not to buy. Now, with the help of K2RR's bibliography, that long-lost article can be found with a quick look in the appropriate table.

In addition, the bibliography makes it easy for the researcher or homebrewer to find just the information he needs to get started on the project put off so many times for want of a few tips from someone who's already tried. K2RR's index of articles will not, of course, give you the information you're looking for — but it will tell you where to find it, and that's very nearly as good.

Each subject category consists of a list — some of them quite lengthy — of the articles compiled for that particular subject. The most recent articles come first. There are seven columns of information on each page, the first of which identifies the subject area as denoted by a four-digit number. (All of the subjects with their four-digit identifying numbers are listed at the beginning of the book.) The second column gives an "Abbreviated Title or Topic Synopsis," which briefly describes the article. The third column gives (in coded form) the publication in which the article appeared, and the fourth column the year and month of publication. The fifth column gives the page on which the article begins and the sixth gives the author's name (except for articles appearing in any of the four major ham magazines). The last of the seven columns is reserved for miscellaneous information and notes that might be useful for purposes of identification.

All in all, it's an impressive bit of work, one which the author says took him four years and many thousands of hours to produce. That's easy to believe, looking at (and hefting) this 620-page mammoth opus. All the information contained in this book has been stored on floppy diskettes (as an alternative to the original IBM punch cards, of which 180 pounds were needed), and the author expects to be able to provide updates with each passing year. If ever there were an example of the value of computer storage, this must be it.

From Beverages Thru OSCAR — A Bibliography is currently available from Rich Rosen, K2RR, at 6043 W. Maplewood Drive, Littleton, Colorado 80123. Rich says that, in addition to the complete volume, he has also made available individual subject chapters for those who would like the benefits of this index but don't need more than a few subject headings.

In our opinion, this is the sort of reference text that many Amateurs will find useful. Our thanks go out to K2RR for having provided the Amateur fraternity with so valuable a tool.

Martin Hanft, WB1CHQ
administrative editor

EITHER WAY YOU GO...2 OR 6!



**GO WITH QUALITY.
GO WITH ICOM.
GO WITH THE BEST.**

The IC-251A is the newest addition to ICOM's all mode transceiver line. Like the matching IC-551, the IC-251A has dual digital VFO's, three memories, scanning (even SSB), and many other features you only get from ICOM.

Both units include the no backlash, no delay light chopper, similar to the IC-701, as a standard feature at no cost. Coupled to the microprocessor, this provides split frequency operation as well as completely variable offsets.

Check the specs, and you'll agree, either way you go, ICOM is simply the best.

SPECIFICATIONS

Listed below are some of the

IC-551 specifications. **IC-251A's** specs are identical except where noted (**in bold**).

Frequency Coverage: 50~54MHz
(**143.8~148.19MHz**)

RF Output Power:
SSB 10W PEP
(1~10W adjustable) (**10W**)
CW 10W
(1~10W adjustable) (**10W**)
AM 4W
(0~4W adjustable) (—)
FM* 10
(1~10W adjustable) (**1~10W**)

Sensitivity: SSB/CW/AM
Less than 0.5 μ V for 10dB S+N/N
FM* More than 30dB
S+N+D/N+D at 1 μ V

Squelch Sensitivity: SSB/CW/AM
1 μ V
FM* 0.4 μ V (**0.4 μ V**)

Selectivity: SSB/CW/AM
More than \pm 1.1KHz at -6dB (**1.2**)
Less than \pm 2.2KHz at -6dB (**2.4**)
(When Pass Band Tuning Unit is installed: less than 1KHz at -6dB)
FM* More than \pm 7.5KHz at -6dB
Less than \pm 15KHz at -60dB

Dimensions: 111mm (H)
 \times 241mm (W) \times 311mm (D)

Weight: 6.1kg (5kg)

Spurious Response Rejection Ratio:
More than 60dB

HF/VHF/UHF AMATEUR AND MARINE COMMUNICATION EQUIPMENT



ICOM

ICOM AMERICA, INCORPORATED

Sales Service Centers located at:

2112 116th Avenue NE
Bellevue, WA 98004
Phone (206) 454-8155

3331 Towerwood Dr., Suite 307
Dallas, TX 75234
Phone (214) 620-2780

ICOM INFORMATION SERVICE

2112 116th Ave., N.E.
Bellevue, WA 98004

Please send me: IC-551 specifications sheet; IC-251A specifications sheet; List of Authorized ICOM Dealers.

NAME _____ CALL _____

ADDRESS _____

CITY _____ STATE _____ ZIP _____

You may send a machine copy of this form

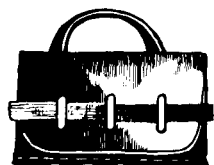

comments

battery charging

Dear HR:

I am writing to you regarding the letter to the Comments column by Robert H. Weibrecht, W6NRM. His comments regarding charging batteries at a low rate are only partly correct. The rest of the story is that the nickel-cadmium battery should be discharged to 1 volt per cell for exercise. This will help to remove the memory induced by continuous charging. Gel batteries, on the other hand, need continuous charging.

D.L. Carlson
Burnside, Minnesota

ground systems

Dear HR:

The article "Ground Systems" in your May, 1980, issue was very interesting. It was particularly interesting to know that the inductive reactance of only 9 feet of wire at 4 MHz can be 100 ohms or so, and that the rf resistance of a wire is some seventy times its dc resistance at 14 MHz! The mention of rf resistance immediately brought to mind Litz wire — three or more strands of insulated wire braided together. I immediately replaced my 12 feet of ground wire with three insulated wires braided together, and it certainly decreases BCI interference! I wonder if anyone has formulas (empirical or otherwise) for the rf resistance of ordinary wire and the rf resistance of Litz wire?

Incidentally, another thing to try if you have BCI problems is to put Amidon FB-801 ferrite beads on the ac or dc power leads just outside or just inside the case of your transceiver. A bead on the "live" side of the mike lead (again, close to where it enters your transceiver or speech processor) may also do some good. Don't put beads on any ground leads!

Keith Wilkinson, ZL2BJR/JG1YCI
Tokyo, Japan

selfish attitudes

Dear HR:

The Observations and Comments column in the August, 1980, issue of *ham radio* asks, "What can be done about the selfish attitudes of those who interrupt contest operation?"

If this were a perfect world with a perfect society, this condition would not take place. However, on the other side of the subject, why should a contest operator come on a frequency in use by others and call "CQ TEST" until he either gets control of the frequency or drives the others off?

It is my firm opinion neither group is completely free of guilt. Don't you think some better planning of worldwide contests should take place? Almost each weekend there is a contest, sometimes on both CW and SSB at the same time. Would limiting the contest to a band of frequencies be the answer? Why should the operators who like to rag chew or keep skeds each weekend be punished? Should we stand in the way of the contest operator? There is no easy solution to the problem and until each side sees the other side of the coin nothing will change.

On "What about slow-scan TV and interference by SSB operation?" I

would say this is a very difficult question to answer at the present time. Until the FCC decides to allow General class operators to use SSTV it is not a good idea what a good approach would be. As 20 meters was the band mentioned in the editorial, I have a suggestion. My thoughts at this time would be to ask the SSTV operators to consider moving from 14.230 MHz to ± 14.270 MHz as a calling frequency. This would put them near the General class end, but not too close to give or take QRM from each other.

Paul T. Atkins, K2OZ
Park Ridge, New Jersey

Q system

Dear HR:

I think the "Q system" is a good idea but should be in reverse order; that is Q1 would be full copy (first class).

Arthur Masthay, W1IUZ
Avon, Connecticut

satisfied reader

Dear HR:

Over the years, *ham radio* has had an evolution toward more technical dissertations. Although the math was minimized, I couldn't help feeling that things were too heavy to be enjoyable. On the other hand, I had a fear that I was growing old for the technology at 47.

The August, 1980, *ham radio* seems to return to more readable articles and a few reasonable construction articles. I hope this is a trend and not a maverick edition. For the first time in several years, I read all the articles.

Don Nelson, WB2EGZ
Vorhees, New Jersey

UNSURPASSED RTTY

No other RTTY terminal made gives you ALL the features of our new DS3100 ASR:

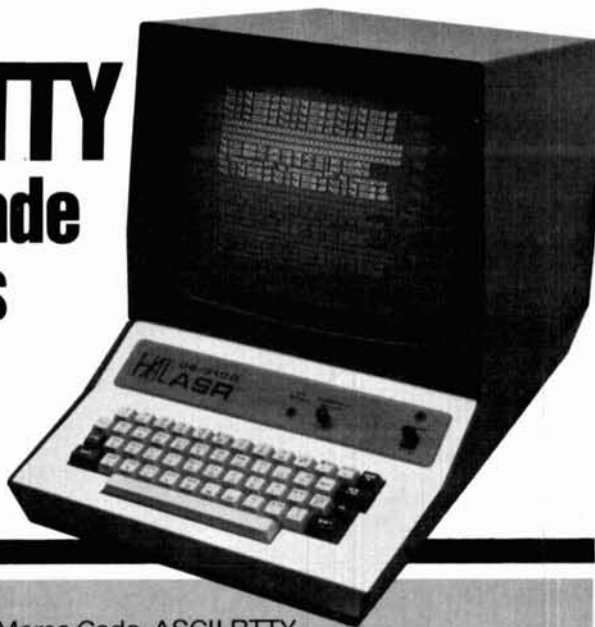

- TX/RX operation with 3 codes: Baudot RTTY, Morse Code, ASCII RTTY
- Storage buffers for 150 lines of RX storage and 50 lines of TX storage
- The HAL "original" split screen shows both RX and TX buffers or whole screen for RX
- Ten programmable "Here Is" messages can be chained from one to next
- The EAROM allows power-off storage of 2 "Here Is" messages and terminal operating conditions
- Programmable WRU answer-back and selective-call features
- Separate CW identification key for RTTY operations
- Automatic TX/RX control with KOS plus 4 keyboard controlled accessory switches
- Internal real time clock keeps 24 hour time plus date
- Newly developed CW receive circuitry and programs give superior CW reception
- New green, P31 phosphor display screen gives clear, eye-easing viewing
- On-screen status indicators give continuous display of terminal operating conditions
- Word-Wrap-Around prevents splitting of words at end of display line
- Continuous, line, and word modes offer flexibility in editing transmit text
- Attractive streamlined metal cabinet gives effective RFI shielding from transmitters

Here Are More DS3100 ASR Specifications that Give You State-of-the-Art RTTY Operation:

QBF and RY test messages ■ Loop and RS 232 RTTY I/O ■ Plus or minus CW key output ■ 25 pin EIA modem connector ■ Half or full duplex ■ Upper-lower case ASCII ■ All ASCII control codes ■ Optional line printer for all codes ■ Selectable ASCII parity ■ 110 to 9600 baud ASCII ■ 45 to 100 baud Baudot ■ 1 to 175 WPM Morse receive and transmit ■ UnShift on space for Baudot ■ SYNC idle for RTTY and Morse ■ Break key for RTTY ■ Tune key for Morse ■ Automatic CR-LF ■ 120/240 v, 50/60 Hz power ■ Custom labeled key tops show control operation ■ Copy receive text into transmit buffer ■ TX flags allow segmenting of TX buffer ■ One year warranty

PRICE: \$1995.00



HAL COMMUNICATIONS CORP.
Box 365
Urbana, Illinois 61801
217-367-7373

For our European Customers Contact:
Richter & Co., D3000 Hannover 1
I.E.C. Interelco, 6816 Bissone/Lugano

*Write or give us a call.
We'll be glad to send you our
new RTTY catalog.*

presstop

FCC'S CW EXAMS WERE CHANGED from the multiple-choice format to "fill in the blank" effective September 28. At the same time the passing grade on the new 10-question exam has been reduced from 80% to 70%. Basis for the change was a detailed study of Amateur exam takers made earlier this year, which indicated applicants who were competent at the required code speed would pass the new exam with ease, while those who weren't could rarely guess their way to a passing grade.

Recent Pass Rate Figures for Amateur exams from two FCC Field Offices, though a limited sample, are quite interesting. While over two-thirds taking the combined Elements 2 and 3 exam—Technician/General without previous Novice—passed; only 43% of those who already had a Novice license did so. Less than 25% of the Advanced Class applicants made the grade, but a third of those going for Extra in Chicago passed—while a whopping 73% (eight out of 11) Denver Extra Class applicants made it.

Part Of These Unusual Results may be due to the introduction of new exams this spring. It's also a common practice to take an exam for "practice," before being fully prepared for it.

COMPUTER DEALERS ACROSS THE COUNTRY WERE HIT recently by a con man operating from suburban Chicago locations. As reported in the September issue of Wayne Green's Micro-computing Industry, a "Thomas Janson" of "CMI, Inc." placed telephone orders with a number of computer supply houses for peripherals and supplies to be shipped C.O.D. Upon delivery the driver was paid by check which eventually bounced, but by the time the sellers had heard the bad news, "Thomas Janson" and "CMI, Inc." were long gone.

"CMI, Inc." First Operated from Riverside and then later Morton Grove, Illinois, and police in either Chicago suburb would be very pleased to hear from anyone with information on it.

10.1 MHZ OPERATION BY TWO CANADIAN Amateurs has been approved by the Department of Communications and should be authorized very soon. In response to a proposal by VE3QB, the DoC has agreed to issue him and VE3DPB VE9 licenses in the experimental services and permit them to operate using very narrow band, low bit rate digital communications anywhere in the 10.1-10.15 MHz future Amateur band. They'll be experimenting with digital data transmission in the presence of QRM, and are prepared to set up for possible 24-hour-a-day communications using computer-controlled stations.

Operation On Any Frequency within the 50-kHz-wide band will be permitted the two experimenters, as the 5-watt limit on output power is unlikely to cause other band occupants problems. As both stations are in the Ottawa area, propagation between them should not be a factor, but the effects of propagation on other interfering signals should provide useful information on problems of digital data communications on the HF bands.

Their VE9 Experimental licenses, which will be valid for a year, were to be issued around the end of September. Regular Amateur use of 30 meters is not scheduled to begin until January 1, 1982.

NATIONAL AMATEUR RADIO ALLIANCE HAS DISBANDED its membership campaign effective August 30, and is beginning to refund the \$10 membership fees collected. A memo accompanying refund money orders explains that while NARA is abandoning all attempts to build a "strong and viable membership," the NARA board wishes to "pursue matters of vital interest to the Amateur fraternity through active lobbying and campaigning," and will remain together.

Questions About Refunds or NARA in general should be sent to Directors Office, NARA, Charlottesville, Virginia 22940. The Connecticut phone number for NARA has been disconnected, with no forwarding number.

A "SOLAR MAX" HOTLINE, providing ionospheric and solar condition reports via the telephone, has been started as a joint service of NASA and the National Oceanic and Atmospheric Administration. The 24-hour hotline provides information on sunspots, solar flares, geomagnetic storms, and the impact of the sun's behavior on radio transmissions. The recording can be reached by dialing (301) 344-8129.

A FORMER CONDITIONAL'S FIGHT for "grandfathering" into General was again rejected by the FCC. WB4AZT had lost his General Class privileges in June, 1972, after his Conditional license was cancelled when he refused to take a 13 WPM code test from an FCC examiner. When the FCC decided to grandfather the remaining Conditionals into Generals in July, 1976, however, he began a four-year battle to upgrade his Technician to General.

The Commissioners Refused his request on the grounds that he no longer had a Conditional to upgrade, since it has been cancelled four years previously. He's now exhausted all administrative avenues, and will have to go to court to continue the fight.

ANASTASIO SOMOZA, FORMER NICARAGUAN leader who was assassinated in Paraguay September 17, had been active on the Amateur bands as YN4AS before he was forced into exile last July.

Move over imports, here's the new TEN-TEC

DELTA

the notable change in hf transceivers



All new, all nine hf bands and only \$849!

DELTA — the symbol of change—the name of a great new TEN-TEC transceiver. A transceiver for changing times, with new features, performance, styling, size and value.

TOTAL SOLID-STATE. By the world's most experienced manufacturer of hf solid-state amateur radio equipment.

ALL 9 HF BANDS. First new transceiver since WARC. 160-10 Meters including the three new hf bands (10, 18 & 24.5 MHz). Ready to go except for plug-in crystals for 18 and 24.5 MHz segments (available when bands open for use).

SUPER RECEIVER. New, low noise double-conversion design, with 0.3 μ V sensitivity for 10 dB S+N/N.

HIGH DYNAMIC RANGE. 85 dB minimum to reduce overload possibility. Built-in, switchable, 20 dB attenuator for extreme situations.

SUPER SELECTIVITY. 8-pole monolithic SSB filter with 2.4 kHz bandwidth, 2.5 shape factor at 6/60 dB points. And optional 200 Hz and 500 Hz 6-pole crystal ladder filters. Eight pole and 6-pole filters cascade for 14 poles of near ultimate skirt selectivity. Plus 4 stages of active audio filtering. To sharpen that i-f response curve to just 150 Hz bandwidth, 4-position selectivity switch.

BUILT-IN NOTCH FILTER. Standard equipment. Variable, 200 Hz to 3.5 kHz, with notch depth down to -50 dB. Wipes out interfering carriers or CW.

OFFSET TUNING. Moves receiver frequency up to ± 1 kHz to tune receiver separately from transmitter.

"HANG" AGC. For smoother, clearer, receiver operation.

OPTIONAL NOISE BLANKER. For that noisy location, mobile or fixed.

WVW RECEPTION. Ready at 10 MHz.

"S"/SWR METER. To read received signal

strength and transmitted standing wave ratio. Electronically switched.

SEPARATE RECEIVER ANTENNA JACK. For use with separate receiving antenna, linear amplifier with full break-in (QSK) or transverters.

FRONT PANEL HEADPHONE AND MICROPHONE JACKS. Convenient.

DIGITAL READOUT. Six 0.3" red LEDs.

BROADBAND DESIGN. For easy operation. Instant band change—no tuneup of receiver or final amplifier. From the pioneer, TEN-TEC.

SUPER TRANSMITTER. Solid-state all the way. Stable, reliable, easy to use.

200 WATTS INPUT. On all bands including 10 meters (with 50 ohm load). High SWR does not automatically limit you to a few watts output. Proven, conservatively rated final amplifier with solid-state devices warranted fully for the first year, and pro-rata for five more years.

100% DUTY CYCLE. All modes, with confidence. 20 minutes max. key-down time. Brought to you by the leader in solid-state finals, TEN-TEC.

QSK — INSTANT BREAK-IN. Full and fast, to make CW a real conversation.

BUILT-IN VOX AND PTT. Smooth, set-and-forget VOX action plus PTT control. VOX is separate from keying circuits.

ADJUSTABLE THRESHOLD ALC & DRIVE. From low level to full output with ALC control. Maximum power without distortion. LED indicator.

ADJUSTABLE SIDETONE. Both volume and pitch, for pleasant monitoring of CW.

SUPER STABILITY. Permeability tuned VFO with less than 15 Hz change per F° change over 40° range after 30 min. warmup—and

less than 10 Hz change for 20 Volt AC line change with TEN-TEC power supply.

VERNIER TUNING. 18 kHz per revolution, typical.

SUPER AUDIO. A TEN-TEC trademark. Low IM and HD distortion (less than 2%). Built-in speaker.

SUPER STYLING. The '80s look with neat, functional layout. "Panelized" grouping of controls nicely human engineered for logical use. New, smaller size that goes anywhere, fixed or mobile (4 $\frac{3}{4}$ "h x 11 $\frac{3}{8}$ "w x 15"d).

Warm, dark front panel. Easy-to-read contrasting nomenclature. Black "clam-shell" aluminum case. Tilt bail.

MODULAR/MASS-TERMINATION CONSTRUCTION. Individual circuit boards with plug-in harnesses for easy removal if necessary. Boards are available.

FULL ACCESSORY LINE. All the options: Model 282 200 Hz CW filter \$50; Model 285 500 Hz CW Filter \$45; Model 280 Power Supply \$139; Model 645 Dual Paddle Keyer \$85; Model 670 Single Paddle Keyer \$34.50; Model 247 Antenna Tuner \$69; Model 234/214 Speech Processor & Condenser Microphone \$163; Model 215 PC Ceramic Microphone \$34.50; Model 283 Remote VFO; Model 287 Mobile Mount, and Model 289 Noise Blanker available soon.

Experience The Notable Change In HF Transceivers, Experience DELTA. See your TEN-TEC dealer or write for full details.

TEN-TEC, INC.
SEVIERVILLE, TENNESSEE 37862
EXPORT 5715 LINCOLN AVE. CHICAGO, ILL. 60648

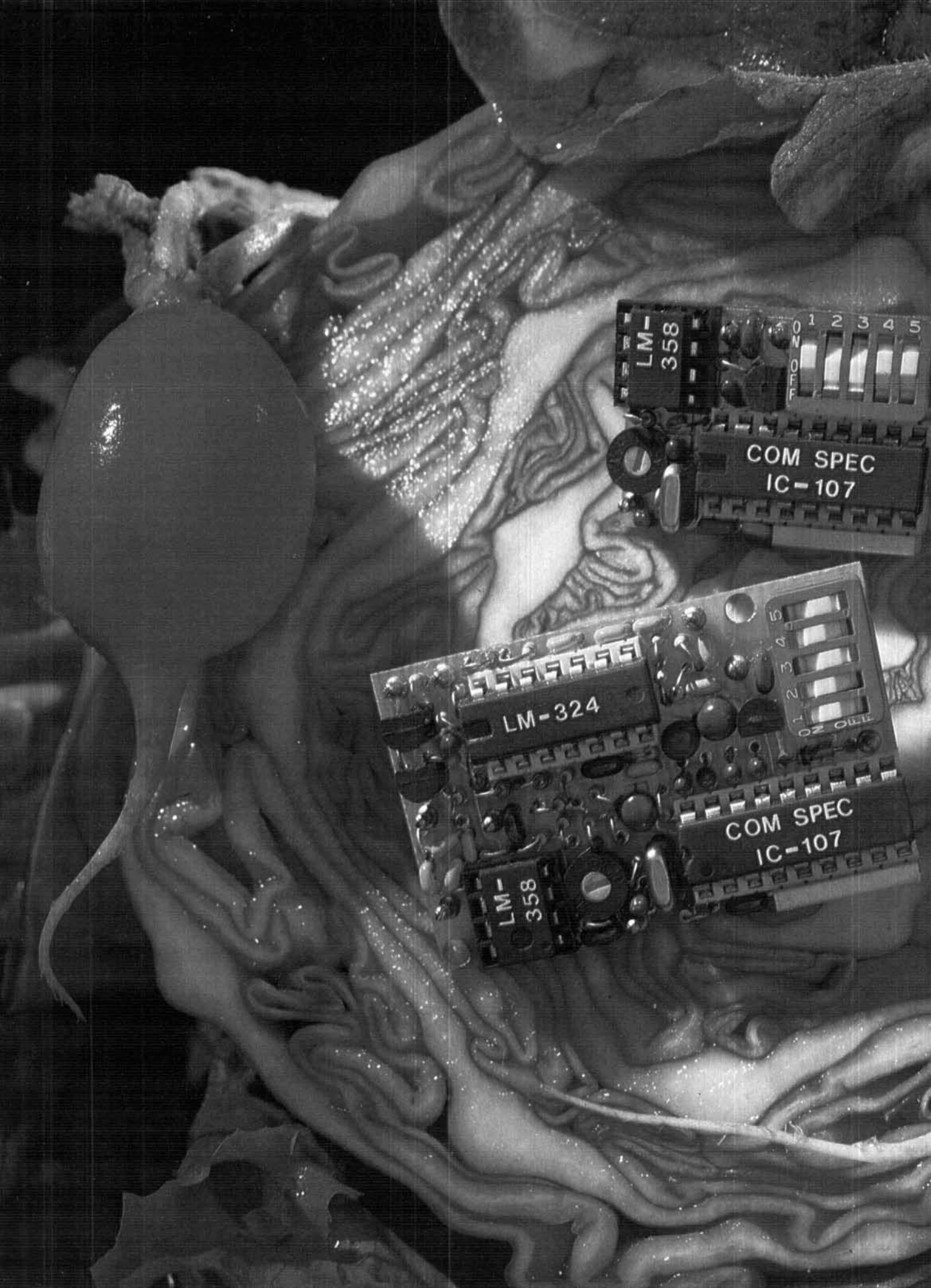

LM-358

1 2 3 4 5

COM SPEC
IC-107

LM-324

1 2 3 4 5 6 7 8 9 10 11 12 13 14 15 16

COM SPEC
IC-107

LM-358

15 14 13 12 11 10 9 8 7 6 5 4 3 2 1

02 OULL

A fresh idea!

Our new crop of tone equipment is the freshest thing growing in the encoder/decoder field today. All tones are instantly programmable by setting a dip switch; no counter is required. Frequency accuracy is an astonishing $\pm .1$ Hz over all temperature extremes. Multiple tone frequency operation is a snap since the dip switch may be removed. Our SS-32 encode only model is programmed for all 32 CTCSS tones or all test tones, touch-tones and burst-tones.

And, of course, there's no need to mention our 1 day delivery and 1 year warranty.

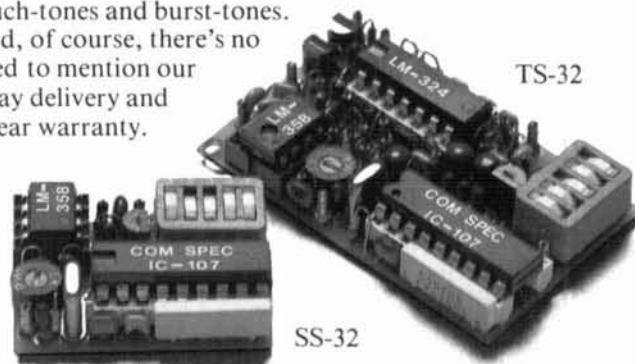

TS-32 Encoder-Decoder

- Size: 1.25" x 2.0" x .40"
- High-pass tone filter included that may be muted
- Meets all new RS-220-A specifications
- Available in all 32 EIA standard CTCSS tones

SS-32 Encoder

- Size: .9" x 1.3" x .40"
- Available with either Group A or Group B tones

Frequencies Available:

Group A			
67.0 XZ	91.5 ZZ	118.8 2B	156.7 5A
71.9 XA	94.8 ZA	123.0 3Z	162.2 5B
74.4 WA	97.4 ZB	127.3 3A	167.9 6Z
77.0 XB	100.0 1Z	131.8 3B	173.8 6A
79.7 SP	103.5 1A	136.5 4Z	179.9 6B
82.5 YZ	107.2 1B	141.3 4A	186.2 7Z
85.4 YA	110.9 2Z	146.2 4B	192.8 7A
88.5 YB	114.8 2A	151.4 5Z	203.5 M1

- Frequency accuracy, $\pm .1$ Hz maximum - 40°C to + 85°C
- Frequencies to 250 Hz available on special order
- Continuous tone

Group B		
TEST-TONES:	TOUCH-TONES:	BURST-TONES:
600	697 1209	1600 1850 2150 2400
1000	770 1336	1650 1900 2200 2450
1500	852 1477	1700 1950 2250 2500
2175	941 1633	1750 2000 2300 2550
2805		1800 2100 2350

- Frequency accuracy, ± 1 Hz maximum - 40°C to + 85°C
- Tone length approximately 300 ms. May be lengthened, shortened or eliminated by changing value of resistor

Wired and tested: TS-32 \$59.95, SS-32 \$29.95

 **COMMUNICATIONS SPECIALISTS**

426 West Taft Avenue, Orange, California 92667
(800) 854-0547 / California: (714) 998-3021



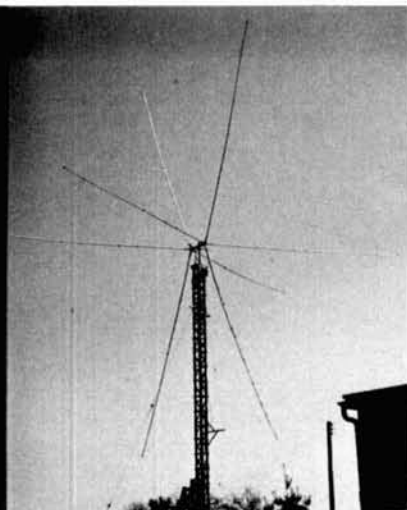

super quad for 7-28 MHz

An ambitious project
for the fellow
who likes to "roll his own"

My interests in DX and DX contests goes back many years. I often marvel at how the state of the art has progressed. Ordinary dipoles, verticals and long wires on 7 MHz worked satisfactorily in those days, as everybody else was using the same thing. By 1964 many DXers on 7 MHz had "grown" good beams, and it became harder and harder to be a winner in the pileups. To stay competitive, I had to think about drastic changes in the 7-MHz antenna department.

early quad experiments

A quad had always intrigued me, so I started to read books and collect information on this antenna. My quad project began back in 1965 after I acquired two telescoping 50-foot (15.25-meter) TV masts and some No. 18 (1-mm) copper-clad wire. These masts were extended another 5 feet (1.5 meters) using aluminum tubing. They were then erected 19 feet (5.8 meters) apart in my 100-foot (30.5-meter) wide backyard. The antenna pointed directly toward Europe.

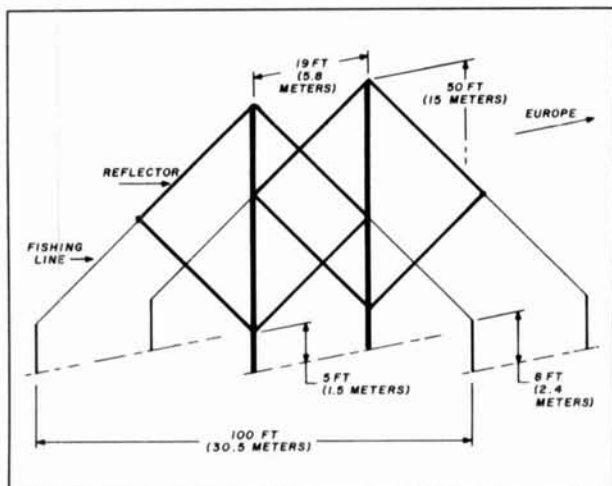

A 2-element 40-meter quad in a diamond shape was supported by these masts. The feed point and reflector tuning point were only 5 feet (1.5 meters) from ground: very convenient for tuning and matching the array. The driven element was fed by a 4:1 balun and RG-8/U coax. The quad was adjusted for minimum backward radiation.

A whole new world opened up. I began hearing European signals that were inaudible on a ground-plane antenna. However, I felt frustrated when I wanted to work DX in different directions and resorted to the ground plane antenna, which was always a good performer for long-haul DX.

After using the two-element fixed quad for a number of years and collecting stacks of data, I decided to make the antenna rotatable and also higher.

design criteria

In 1970 I arrived at the fundamental design concepts:

1. All elements to be full size.
2. The longest metallic object in the system to be 13 feet (4 meters) maximum.
3. Incorporate concentric quads for 40-20-15-10 meters.
4. Boomless or very short boom design.
5. Separate feed lines for each quad.
6. Nonmetallic tower (see 2 above).
7. Center of quads to be 44 feet (13.4 meters) above ground.
8. One person can raise and lower the array for tuning or repair.
9. Cost to be \$250 maximum.
10. Use diamond configuration in the design.
11. Keep the 19-foot (5.8-meter) spacing from driven element to reflector.

It took a year to complete the design and construction of this project with much redesign along the way, and in July 1972 the array design was fixed.

By Frederick Hauff, W3NZ, 437 South Lewis Road, Royersford, Pennsylvania 19468

From necessity many features of the entire system (tower, rotator, winch) are merely touched upon in this article, major emphasis being on design and construction of the antenna.

construction

Fig. 1 shows the construction of the spreader or spider arms. A list of tubing is given below.

Spreaders. To insert the 1-3/8 inch (34.9 mm) tubing into the 1-1/2-inch (37.9-mm) tubing, both parts must be straight, round and burr-free. The insert must be thoroughly lubricated on the outside; the same goes for the inside diameter of the 1-1/2-inch (37.9-mm) tube. I was able to insert all eight pieces with the help of a rawhide mallet by placing one end of the 1-1/2-inch (37.9 mm) tubing against a tree stump. However, it's advisable to slot the 1-3/8 inch (34.9 mm) tubing lengthwise for 30 inches (76 cm) with a saber saw, then deburr and insert the slotted end first. The 72-inch (183-cm) long tubing was polished on one end, lubricated, then driven into the tubing as shown in fig. 1. Make sure the tubing has entered at least 2 inches (5 cm).

Bushings. The insulating bushings are needed to comply with item 2 of the design criteria. The electrical length of the spider arms is 12 feet (3.7 meters) maximum. I turned these bushings on a small bench lathe. Take care to have good concentricity and roundness. For this reason the outside diameter was turned last by pushing the finished inside diameter onto an arbor made of plastic. I used scrap pieces of nylon, Delrin, and PVC. After the bushings were completed they were placed on the respective tubing sections as shown in fig. 1 and held in place with epoxy.

The spreader arm is now ready to be assembled as in fig. 1. Stainless steel hose clamps were used as shown.

List of aluminum tubing. All items listed (Page 14) are 12-foot (3.7-meters) long 6061-T6 drawn round aluminum tubing. All items must be straight and round! No defects accepted. The total cost of these items in 1971 was \$105.52. Three 12-foot lengths of 1-1/8 OD x .058 inch (28.4 x 1.5 mm) wall tubing should be added for the optional reinforcement of parts shown in detail 1, fig. 1.

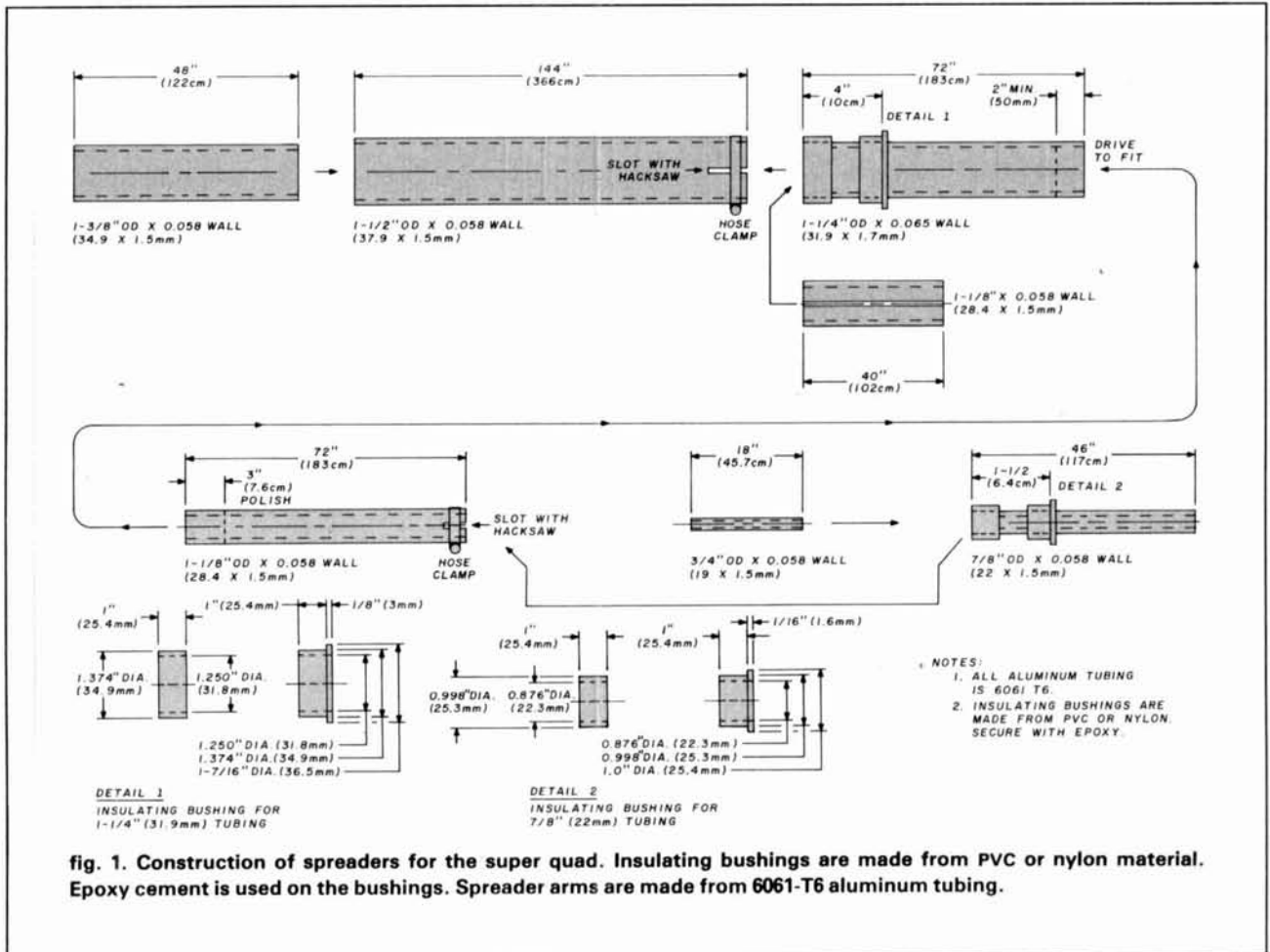

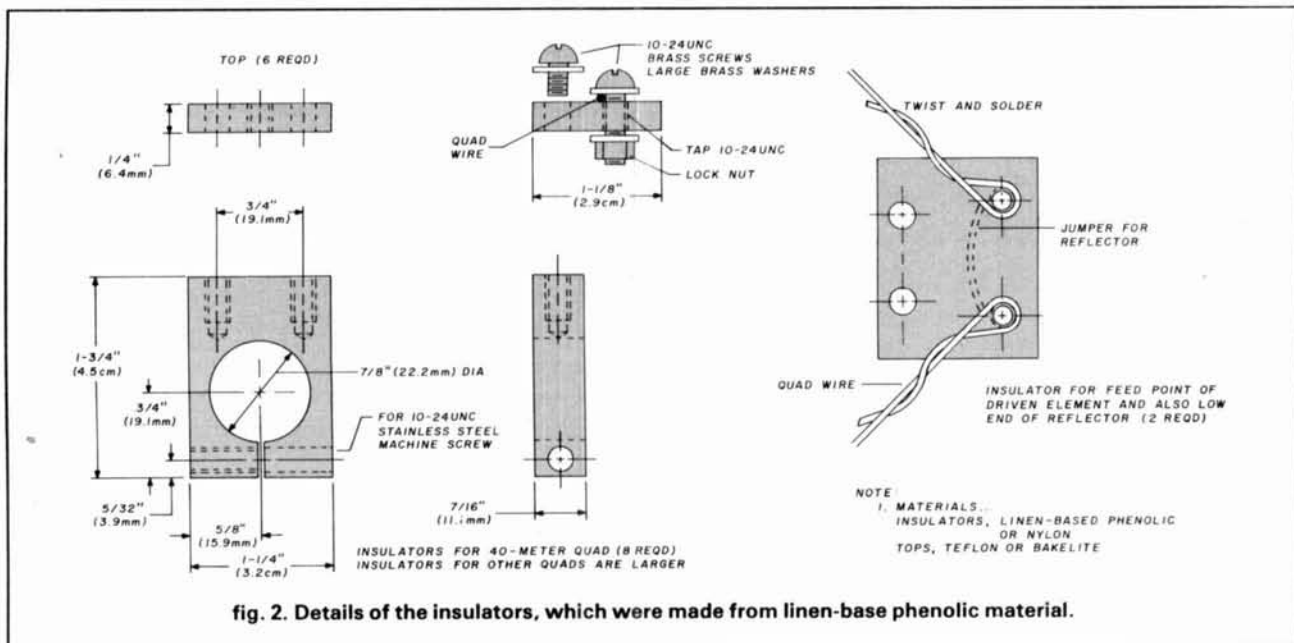

quantity	size	weight
8	1 1/2 OD x .058 (38 x 1.5 mm) wall	30 lb. (13.6 kg)
3	1-3/8 OD x .058 (35 x 1.5 mm) wall	11 lb. (5 kg)
4	1 1/4 OD x .065 (32 x 1.7 mm) wall	13 lb. (6 kg)
4	1-1/8 OD x .058 (28.4 x 1.5 mm) wall	11 lb. (5 kg)
3	7/8 x .058 (22 x 1.5 mm) wall	6 lb. (2.7 kg)
1	3/4 OD x .058 (19 x 1.5 mm) wall	1.77 lb. (1.5 mm)
		72.75 lb. (33 kg)

Insulators and brackets. A suitable insulator had to be designed and made to hold the quad wires to the spreader arms. Fig. 2 shows the insulator for the 7-MHz quad. The 20-meter quad insulator clamps onto the 1-1/4-inch (31.9 mm) tubing; the 15- and 10-meter insulators clamp to the 1 1/2-inch (37.9 mm) tubing. Variation of the insulator size must be made accordingly. The first insulators I made were without the Teflon part. During the first rain storm, rf voltage arced from the brass screw to the tubing and burned up the insulators on the high-voltage points of the driven element.

The quads are fed at the lower corner of the driven element, so I also made up some supporting brackets for the coax cables that run down the lower front spreader arm. Fig. 3 shows details for this support.

These insulators and brackets were made in my work shop using a small lathe and drill press. All the insulating supports were clamped onto their respective spreader arms in the precalculated positions. I've omitted dimensions for these locations. To calculate these points is a good mental exercise, and every high-school student should be able to arrive at the correct numbers. Final adjustments can be made after stringing the quad wires.

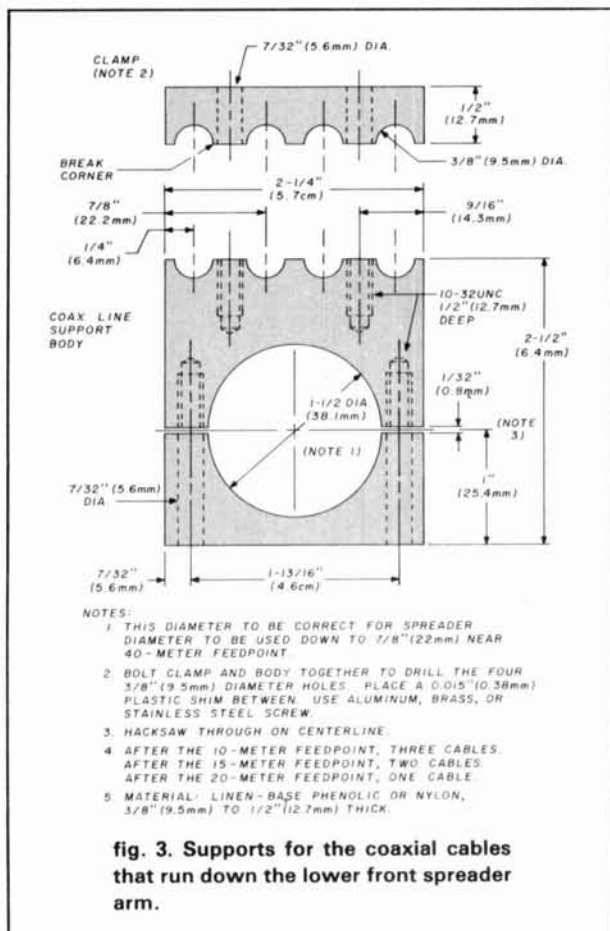

Boom and associated hardware. The boom is a length of solid PVC measuring 30 x 3 inches (76 x 7.6 cm). Nylon or Delrin could also be used. Great care must be taken when drilling the eight 3/8 inch (9.5

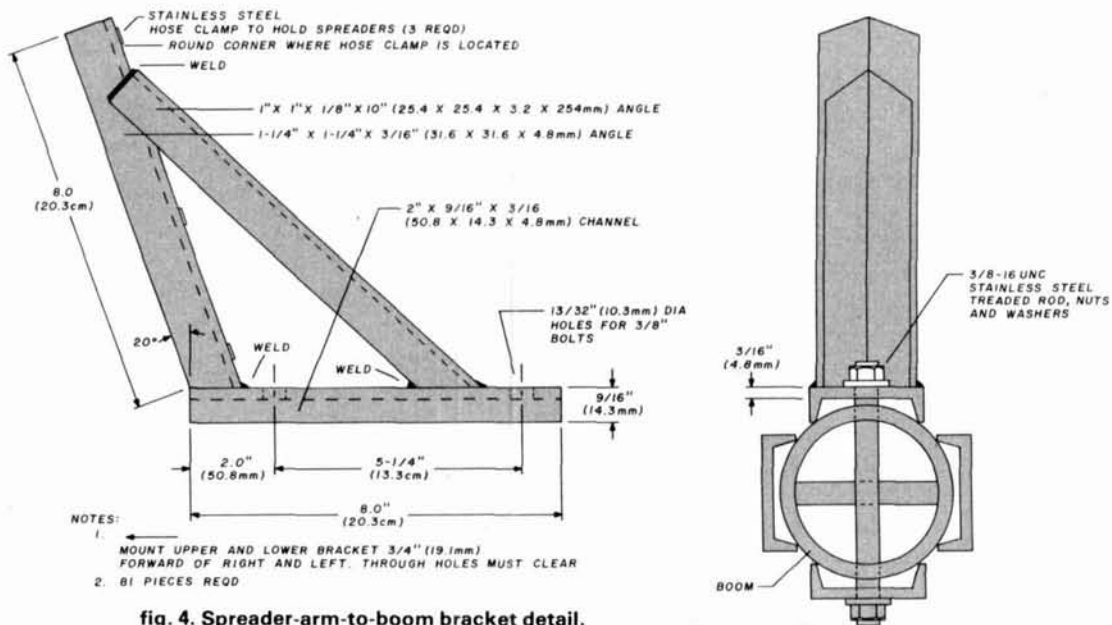

fig. 4. Spreader-arm-to-boom bracket detail.

mm) through-holes to ensure good angular alignment of the spreader arms. Also, the holes for the upper and lower boom-to-spreader-arm brackets must be about 3/4-inch (19-mm) in front of the horizontal brackets so that the 3/8-inch (9.5 mm) through-bolts won't interfere with each other. I drilled these holes on a vertical milling machine in a friend's machine shop.

The boom-to-mast plate is 1/4-inch (6.5-mm) thick steel plate. Four U bolts must be used to clamp the boom to the plate and four U bolts to clamp the plate to mast. At the beginning, I used only two U bolts for each, but the first heavy wind gave me the needed education!

Spacing between driven element and reflector is 19 feet (5.8 meters) for the 40-meter quad (0.136λ). It's not a magic number but it worked well on the fixed quad and it also provided clearance between lower spreader arms and guy wires for the tower.

The theoretical angle from vertical for the spreader arms to point outward is 17°48'. However, some preloading of the tension cords that run from the front to the rear spreader arms near the ends is needed. I chose an angle of 20°, which amounts to 12 inches (30 cm) at the end of each arm.

Fig. 4 shows the spreader-arm-to-boom bracket. I had all parts ready cut, shaped, and drilled. Then, with a template to assure the correct 20° angle, they were taken to a welder.

After welding, I gave the brackets a few coats of zinc chromate (galvanizing would have been better by far).

These brackets were mounted to the boom with stainless-steel threaded rods, cut to size, and stainless-steel washers and nuts on each end of the rods.

To conform with items 2 and 6 of the design criteria, I made the tower of wood. It's a foldover tower.

When in a vertical position, it has four guy wires (broken with insulators). The uprights for the 40-foot (12-meter) fold-over section are straight pieces of 2 x 4 lumber 20 feet (6 meters) long. The tower is 14 inches (36 cm) square (to the outside of the uprights).

The horizontal braces, which also serve as rungs for climbing the tower, are 1 x 3 lumber; the diagonals are 1 x 2 lumber. No. 10 wood screws 1.5-inch (38 mm) long and waterproof glue were used in the construction. The hinge pin is a 1-inch (25.4-mm) diameter stainless-steel rod. Hinge members are aluminum plates 3/8-inch (9.5-mm) thick, which were bolted to the uprights. The tower hinge point is 16 feet (4.8 meters) from ground. A wooden tower section, 16 feet (4.8 meters) high, is permanently bolted to 4-inch (10-cm) channels, which are embedded in a concrete base. I placed four screw-in anchors equidistant from the center of the foldover section on a 16-foot (4.9-meter) radius. Fig. 5 shows the tower and the quad.

The winch, which is used to raise and lower the

fig. 5. Photo showing the homebrew wooden tower and quad ready for erection.

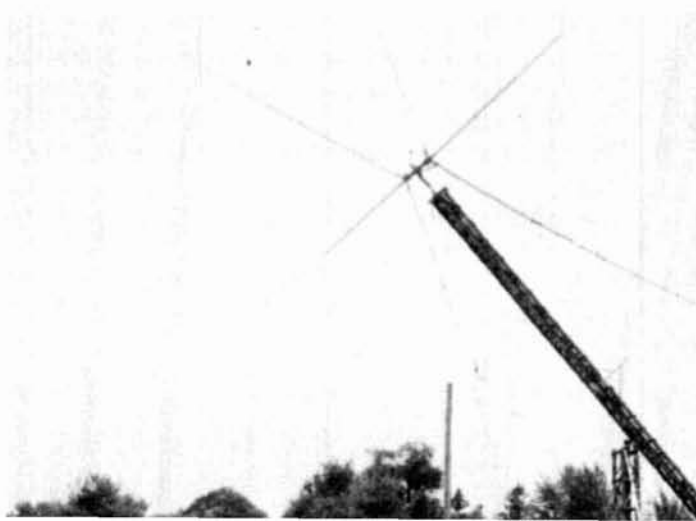

tower, is also home built and uses a 50-tooth, 1° pitch, single-thread worm gear for safety. A 1/2-inch (25.4-mm) diameter reversible 500 rpm electric drill chucked to the tower worm shaft is used to raise and lower the tower.

The rotator also uses worm gears. It's mounted 8 feet (2.4 meters) from ground inside the tower. A 2-inch (51-mm) galvanized water pipe is used for the mast. A thrust bearing is located 8 feet (2.4 meters) from the top. The drive shaft from rotor to mast is also 2-inch (51-mm) galvanized pipe. To conform to my design criteria, it was broken into three sections, which are coupled together with solid PVC couplings as insulators. Again, I want to bring to your attention the enormous stresses that are applied to these parts during strong winds.

assembly

With the tower lowered, resting on a 13-foot (4-

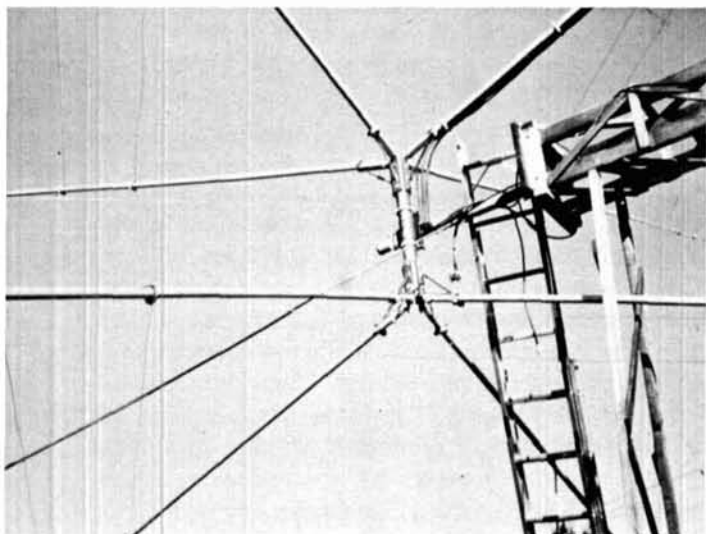

fig. 6. Photo of antenna showing extension ladder, which was used to assemble the elements and feed system.

meter) high A frame, and guyed to right and left for safety, the antenna assembly begins. An extension ladder was used (see fig. 6).

The boom was mounted to the mast, then the four driven-element spreader arms were mounted to the brackets. Use three stainless-steel hose clamps (or more). (To meet item 2 of the design criteria I insulated the arms from the brackets.) I used strips of vinyl between arms and brackets and also under the hose clamps. I used 19-foot (5.8-meter) long stress cords attached to the upper vertical spreader arm near the end and also to both horizontal arms. I used small weights on the loose ends. At this time the tower was raised to the vertical position. I rotated the antenna 180 degrees, then lowered it. The other four spreader arms were then clamped to the brackets,

and the stress cords were fastened to the reflector set of spreader arms.

At this point we're ready to attach the quad loops to the insulators. When I first erected the fixed quad, I used the formulas for the loop length from the *ARRL Antenna Book*:

$$\text{driven element (ft)} = \frac{1005}{f(\text{MHz})};$$

$$\text{reflector (ft)} = \frac{1030}{f(\text{MHz})} \quad (1)$$

I found that these numbers were wrong in my case. For my rotary quad I used:

$$\text{driven element (ft)} = \frac{994}{f(\text{MHz})};$$

$$\text{reflector (ft)} = \frac{1019}{f(\text{MHz})} \quad (2)$$

The constants 302 and 309 may be substituted into the numerators of eq. 2 for calculating lengths in meters. The lengths, from eq. 2, are 141.5 feet (43.2 meters) for the driven element and 145 feet (44.2 meters) for the reflector.

The reflector is slightly less than 2.5 per cent longer than the driven element, and the adjustment is critical. In any event, the reflector must be tuned for minimum backward radiation. (I was not concerned with SWR while tuning for maximum front-to-back ratio.) All quad loops were fastened to the insulators, which were placed in the calculated positions on the arms.

feed system

The quad is fed by 52-ohm coax and a 75-ohm quarter-wave matching transformer. One coax line runs to a relay box at the top of the tower where the desired quad is selected by one of four relays. (The inner conductor of the unused lines is *not* grounded.) The five-wire control line to the relays was decoupled 13 feet (4 meters) from the relay box by winding three turns of this control line through a 2-inch (51-mm) diameter toroid.

tune up

For tuning the quad I put a sensitive field-strength meter with a 20-foot (6-meter) long horizontal pickup dipole 6 feet (2 meters) from ground, about 200 feet (60 meters) from the quad. I pointed the quad toward the field-strength meter and fed a small amount of rf at 7050 kHz into the quad to give a full-scale meter reading. I then pointed the back of the quad toward the meter. The reading should drop to about 1/50th of full scale, which is close to zero. At this point I adjusted the meter reading to about half scale then varied the frequency plus and minus but maintained the same output from the transmitter. Wherever the

minimum reading on the meter occurred I considered to be the maximum performance (maximum front-to-back ratio) operating frequency. Record it!

I used the same procedure for the 14-MHz antenna. I cranked the tower down, with the reflector facing the ground, then made precalculated adjustments to the reflector only. (In my case the desired frequencies were 7020 kHz and 14020 kHz).

The 40-meter elements turned out to be as mentioned before. The 20-meter driven element is 71 feet (21.7 meters); reflector is 72 feet, 8 inches (22.2 meters), and the spacing is 12 feet, 8 inches (3.9 meters).

standing-wave ratio

The SWR of the 7020-kHz quad is near 1:1. That of the 14020-kHz quad is 1.5:1. The 21-MHz and the 28-MHz quads have not been tuned as described. However, the SWR on 21020 kHz was very high and I substituted a gamma match, which improved the SWR. I think that the gamma match is superior to the matching transformer.

I think the spacing is too great for the 21- and 28-MHz quads. I wasn't able to obtain the excellent results as with the 7- and 14-MHz quads. (Remember the spacing of the higher-frequency quads is not proportional to the 7-MHz quad since the boom is a constant.) But once I had the two lower bands working I never took the time to improve the 21- and 28-MHz antennas. It's too much fun to sit behind the loud-talking 40-meter antenna!

front-to-back ratio test

After the 7-MHz quad was completed and tuned I placed the back toward the field strength meter again. I shorted the insulated drive-pipe section. Nothing happened to the front-to-back ratio. Then I short circuited the guy-wire insulators and short circuited the guy wires to the drive pipe. Nothing happened to the front-to-back ratio. However, when I short-circuited two spreader arms to the mast, a definite deterioration of front-to-back ratio occurred. This test was only made on 7 MHz to satisfy my curiosity.

performance

Many times I switch from the 40-meter quad to my ground-plane antenna and some signals just turn into a faint scratching sound, whereas they were RST 559 on the quad. It's mind boggling when a European station receives me RST 599, and after I turn the antenna backside toward him, he loses me completely.

I also have a tribander TH6DXX at 74 feet (22.6 meters). I can compare the 14-MHz quad with the

Yagi at the flip of a switch. [The center of the quad is only 44 feet (13 meters) from ground.] On long-haul DX the high Yagi always out performs the quad.* Signals from Europe and Central America improved up to three S units on the quad under wide-open conditions. When band conditions are low, the Yagi takes over. When the 20-meter band gets wiped out by rain static on the Yagi, I switch to the quad. Lo and behold! no static, only signals.

maintenance

In seven years I replaced the loop wires in the 14- and 7-MHz quads twice. During an ice storm the reflector wire broke on the 7-MHz loop. The ice loading kinked the 1-1/4-inch (31.75-mm) tubing section of the upper spreader arm. The ice on the wire measured 1/2-inch (13 mm) in diameter, and the tubing was 1-3/4 inches (44.5 mm) from the ice buildup. It required only six hours to put the quad back into operation again, and the nicest part was that I could do it all by myself.

cost-reduction tips

To keep within the \$250 limit, the use of the junk-box was mandatory. I also visited a few surplus houses where I was able to pick up stainless-steel aircraft cable for \$.05 per foot, 18-inch (45.7-mm) turn-buckles for \$2.00 each, and worm gears and worms for \$5.00 per set. I cultivated the friendship of a machine-shop foreman who saved scrap aluminum plates, old steel shafting, and nylon scraps for me. I bartered a case of beer for the welding of the boom-to-spider brackets. Such is the stuff of which hams are made.

Would I do it over again? The answer is yes! However, since making the different tests I would be brave enough to use a heavy-duty commercial 50-foot (15-meter) foldover tower. Who is adventurous enough?

This has been a fun project. The greatest reward has been getting into a pileup and having those rare ones come back to me.

acknowledgement

Many thanks to N3RD, who was my critic and coordinator. I appreciate the suggestions of N3ANW. Special thanks go to my dear wife, who was always ready to help with holding and signaling chores. She kept the meals warm on many occasions and never blew her Irish fuse!

reference

1. Wayne Overbeck, N6NB, "Quads vs. Yagis Revisited," *ham radio*, May, 1979, pages 12-21.

*See Wayne Overbeck's article¹ on this controversial subject. Editor.

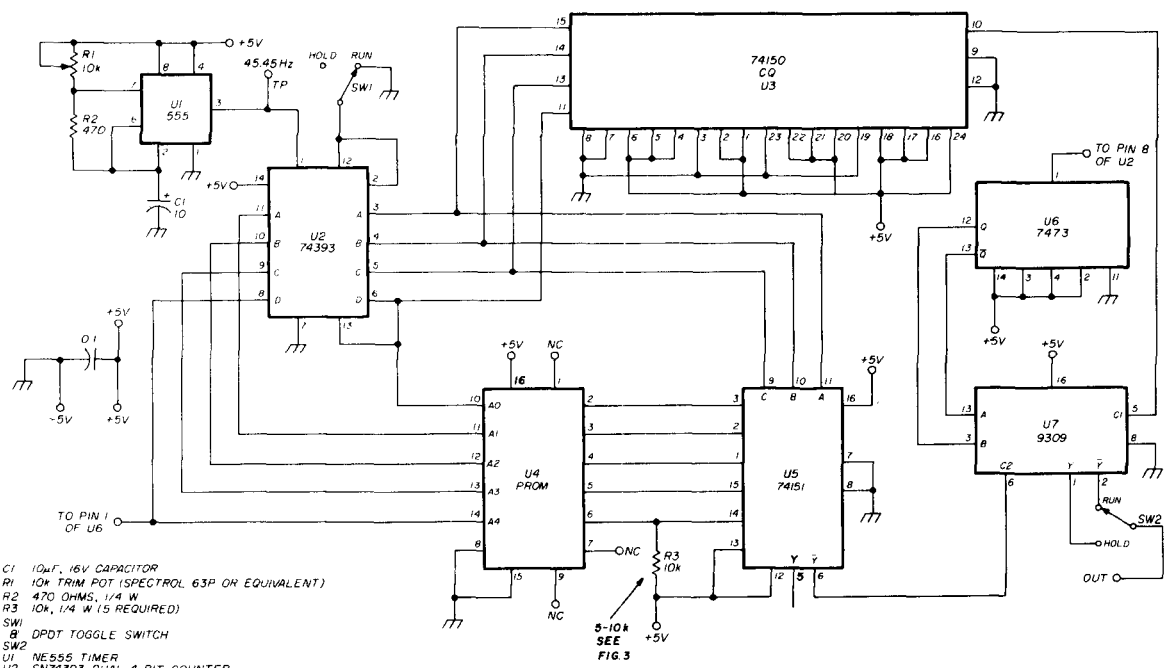

- C1 10μF, 16V CAPACITOR
- R1 10K TRIM POT (SPECTROL 63P OR EQUIVALENT)
- R2 470 OHMS, 1/4 W
- R3 10K, 1/4 W (5 REQUIRED)
- SW1 DPDT TOGGLE SWITCH
- SW2 DPDT TOGGLE SWITCH
- U1 NE555 TIMER
- U2 SN74150 DUAL 4-BIT COUNTER
- U3 SN74150N 16-LINE-TO-1-LINE MULTIPLEXER
- U4 PROM (82S23, 82S123 ETC.)
- U5 SN74151N 8-LINE-TO-1-LINE MULTIPLEXER
- U6 SN7473N DUAL JK FLIP-FLOP
- U7 DM9309 DATA SELECTOR

fig. 1. Schematic of the NS-CQ automatic CQer for RTTY. It uses only seven ICs. It sends 16 CQs without spacing; then DE; then your call sign three times; and finally CR LF. Note that five 10-k resistors are required from +5V to each of the five inputs to U5.

This IC is very similar to the 74150 except that it has only eight inputs.

Since the start and stop pulses are always the same, U5 has its first position grounded for the start pulse, and the final seven and eight positions are wired to +5 V for the stop pulses. Now all that's needed from the PROM are the five-bit data. Note there are five 10k resistors from +5 V to each of the five inputs of U5. These are necessary because some of the PROMs used have open-collector outputs.

Because the PROM outputs are in parallel and connected to U5 multiplexer inputs, PROM IC must run eight times slower to give U5 time to scan all eight inputs. This is done by taking off the proper count from U2. The PROM used here is described as a 32 x 8, or organized as 32 words of eight bits each. This can be thought of as a ladder with 32 rungs or "address positions." Each of these address positions has a storage capacity of eight bits. The address positions are advanced one position at a time with the proper binary code from counter U2.

interfacing the CQer

Output from the NS-CQ is taken from either pin 1

or pin 2 of U7. **Fig. 1** shows output from pin 2. This will give approximately 5 V on mark and 0V on space with the transmitter in LSB mode. The two outputs are opposite. When one is high the other is low. As shown, the output on pin 2 is low when reset pins 2 and 12 of U2 are above ground. This position resets the counter to zero, which stays there until again grounded. The dpdt switch changes the output of U7 pin 2 to pin 1, which is high, so the machine will hold in a mark condition during standby. If your setup is inverted with connection to pin 2, just reverse the two leads going to the dpdt switch.

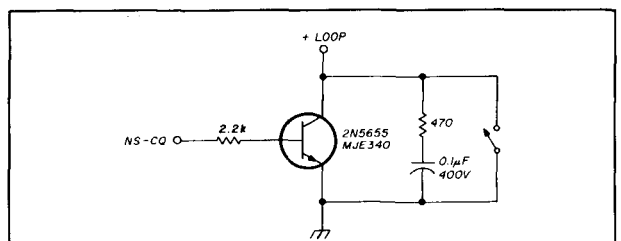

fig. 2. Alternative keying circuit that can be inserted in series with the loop.

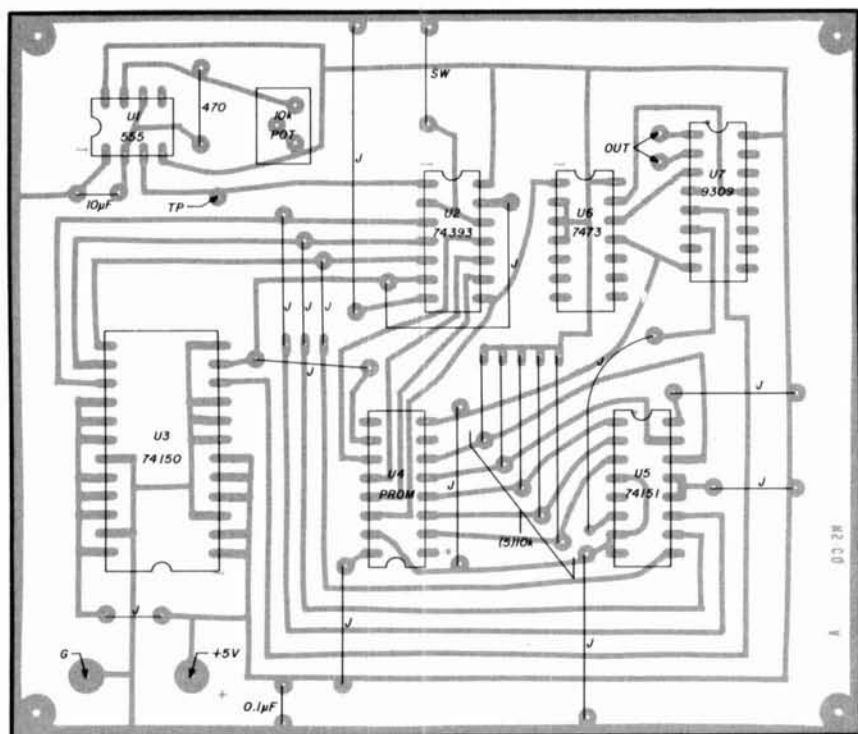

fig. 3. Parts placement on PC board. Note notch on each IC for correct placement on board.

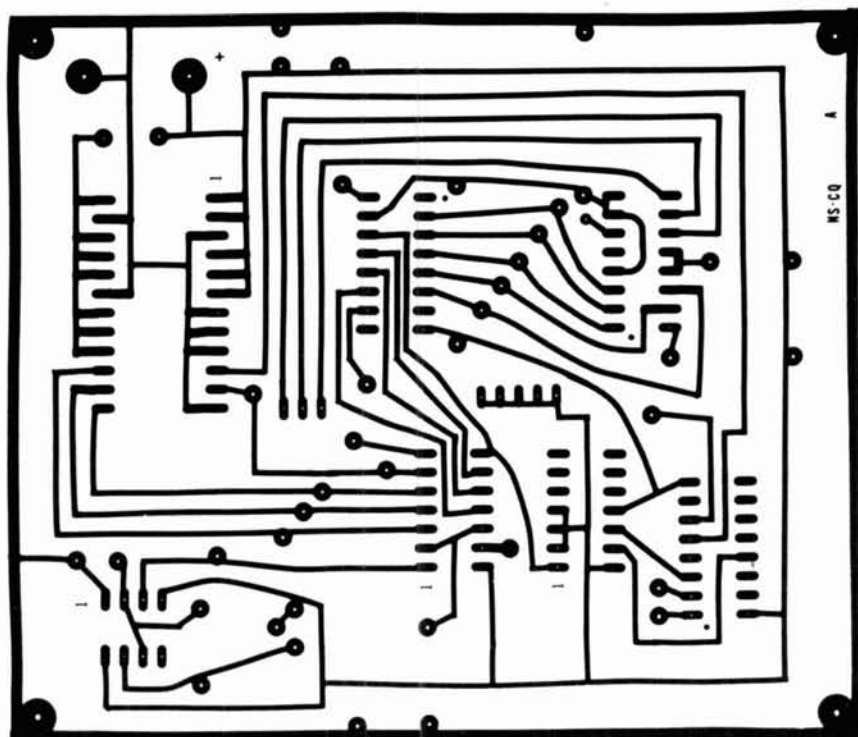

fig. 4. Foil side of the NS-CQ PC board. Boards are available from author (see text).

Most machines have the keyboard in series with the loop supply for local copy, and associated circuitry produces a keying voltage for FSK or AFSK. If your TU has a loop keying transistor, as shown in **fig. 2**, you can lift the base resistor at the far end and connect the NS-CQ output here. Another method would be to insert another keying circuit, as in **fig. 2**, in series with the loop. For AFSK, the NS-CQ output can usually replace the normal keying voltage going to your AFSK tone generator. For example, the NS-CQ will drive the *Mainline AK-2* directly. All these changes can be made with toggle switches.

construction

Construction is straightforward with a PC board.* Use a low heat soldering iron with small solder, not more than No. 18 (1 mm) in size. Refer to **fig. 3** for position of components and jumper wires.

It is strongly recommended that sockets or Molex pins be used for the ICs. This simplifies removal of an IC if necessary. If Molex pins are used, first solder the pins then remove the top tab by bending it over once or twice. **CAUTION:** It is imperative that each IC be inserted in its socket in the proper way, otherwise it may be destroyed. Each IC has a notch or deep circular indentation on one end as viewed from the top. This notch should line up with that on the parts placement diagram (**fig. 3**).

After soldering all components, check for solder bridges between pins and between circuit traces that are close together. Connect -5 V and ground to proper terminals. **Fig. 4** shows the foil side of the board.

Set R1 to 45.45 Hz with a frequency counter connected to TP. If no counter is available, you can get proper speed by slowly adjusting R1 while observing printout on the machine. Set R1 so that machine runs and prints smoothly.

the PROM

Several different types of PROMS are available. Some come with all outputs high and some with all outputs low. Using a Baudot table, a letter or function is made by changing one output bit at a time from high to low, or from low to high, as required. Special equipment is needed to do this; but simply stated, it consists of pulsing a certain voltage on an output pin for a length of time in the microsecond-millisecond range. Consult the data sheet of the PROM for proper procedure. I've found the following ICs to be the easiest to program: 82S23, 82S123, 7577, and 7578.

*A few partial kits consisting of board and programmed PROM, and a few wired and tested units are available. Send a SASE to author for prices and information.

ham radio



Kitty's November Suggestions

BARRY'S HAS HAND-HELDS

Yaesu FT-207R
Icom IC-2AT
Tempo S-1, 2, 5
Santec HT-1200



Come to **BARRY'S** for your
YAESU transceivers and receivers.



The outstanding **FT-707** or
consider the **FT-107** or the
NEW 9-Band FT-101ZD

See the **Yaesu FRG-7000** and the top rated*
FRG-7 receivers.

NOVEMBER FEATURES

GLA 1000B

MIRAGE 2M amplifiers • MURCH UT 2000B

It's **Barry's** for the **Drake TR/DR-7** and **R-7**

CW Ops — we've got **NYE keys** and
Bencher paddles

**BARRY'S HAS TUBES -
LOTS OF TUBES!!!**

BARRY now carries the **ALPHA 76PA**
with three 8874 tubes, 2,000W PEP

Our lines include:

AEA	DRAKE	MURCH
ALLIANCE	ETO	ROBOT
ASTRON	EIMAC	SHURE
AVANTI	ENCOMM	STANDARD
B & W	HUSTLER	SWAN/CUBIC
BIRD	HY-GAIN	TEMPO
COLLINS	ICOM	TRI-EX
COMMUNICATIONS	KLM	VHF ENGINEERING
SPECIALISTS	KANTRONICS	WACOM
CUSHCRAFT	MFJ	YAESU
DSI	MIRAGE	AND MORE...
DENTRON	MOSLEY	* Ask us for details.

BUSINESSMEN: Ask about **BARRY'S** line
of business-band equipment. We've got it!

Amateur Radio License Classes:

Wednesday & Thursday: 7-9 pm
Saturday 10 am-Noon

The Export Experts Invite Overseas orders

¡ AQUÍ SE
HABLA
ESPAÑOL !

— We Ship Worldwide

BARRY ELECTRONICS

512 BROADWAY, NEW YORK, N.Y. 10012

TELEPHONE (212) 925-7000

Yagi antenna design: stacking

Data for various stacked Yagi configurations

This article describes the use of multiple Yagi antennas arranged into a coherent antenna system. The number of potential arrangements is unlimited, but certain basic configurations deserve detailed analysis because they have attractive properties. To start, I shall limit the discussion to systems where the individual Yagi antennas are all physically identical and aligned for maximum radiation in the same direction. Moreover, to ensure that each Yagi contributes to the overall main radiated wave front in a coherent manner, I shall limit the configurations to those in which the Yagi positions (say, for example, the reflector end of the boom) lie in a plane perpendicular to boom direction. Usually all of the Yagis are coherently excited by the same driver current (magnitude and phase). Using identical Yagis positioned in such a plane helps maintain a uniform radiated pattern over a desired frequency band. The overall system beam pattern can be pointed in azimuth only by mechanically rotating the entire system.*

*The radiated beam from a mechanically fixed (system) array of laterally spaced Yagi antennas can, in principle, be steered in azimuth by changing the excitation phase to each Yagi antenna. However, the beam quality generally deteriorates. Such mechanically fixed, electrically steered phased arrays are not considered here.

The overall system array can be viewed as a large-area aperture illuminated in a quasi-uniform way by the individual Yagi antennas. So long as the individual Yagi antennas are not too far apart (so that illumination is relatively uniform), the system gain should be *proportional to the total effective aperture area*. The system beam pattern should also show an angular width inversely proportional to the aperture dimension. Thus, in concept, a horizontal array of Yagi antennas (horizontally polarized) should produce a narrow horizontal system beam pattern; similarly, a vertical array of Yagi antennas (horizontally polarized) should produce a narrow vertical system beam pattern.

We must consider the system array over earth or ground; in this case all of the effects mentioned previously¹ will occur. Recall that ionospheric paths over earth primarily favor low radiation angles (up to say, 20 degrees); moreover, this whole range of antenna radiation angles should be covered to accommodate a continuous earth range as well as different multi-mode ionospheric paths. We shall see that, by vertically stacking two or more horizontally polarized Yagis over ground, it is possible to improve significantly low-angle performance (over that of a single Yagi antenna over ground) *without* reducing the azimuthal coverage. This improved result comes about through a suppression of otherwise useless radiation at the higher angles.

By James L. Lawson, W2PV, 2532 Troy Road,
Schenectady, New York 12309

stacked Yagi antennas

For Amateur Radio communications relatively wide horizontal or azimuthal coverage is generally desirable, not only to make a given contact less sensitive to critical beam heading but to accommodate the many occasions in which the communication path is somewhat skewed due to ionospheric conditions. Wide azimuthal coverage is especially desirable under contest conditions, where it is advantageous to have the beam simultaneously illuminate the largest desired Amateur population. So a horizontal array of Yagi antennas doesn't appear as desirable as a vertical stack;* therefore I shall not attempt analyses of such horizontal arrays.

Vertically stacked Yagi arrays are now in reasonably wide use. It is interesting to study the theoretical performance of such systems. Before attempting a formal analysis, I will make two observations. First, vertical stacking requires a supporting mast. If the stacking separation is large (which we shall find desirable), the large mast must be entirely rotatable and, of course, very rugged mechanically. Such a mast, including its foundation, is a major undertaking.

Two interesting variations of this system are not as formidable. The first variation is a stacked Yagi antenna array offset from a fixed, or guyed, tower. The offset allows simultaneous rotation of the Yagi antennas over a range in azimuth of about 300 degrees; at either end of this range, the antennas are designed to nest around the mast. I use this construction for a stacked 28-MHz, 6-element Yagi antenna system on a Rohn 45 guyed mast. It works very well and is cost effective.

The second variation is to use a fixed, or guyed, mast with the top Yagi antenna fully rotatable and a second, lower, Yagi antenna fixed in a preferred direction. This is a particularly interesting variation for contest operation, especially on the lower frequencies where the mast must be very high.

My 7-MHz system is a good example. A full-sized, three-element beam is fully rotatable on top of a 180-foot (55-meter) Rohn 45 guyed mast. A second full-sized, three-element beam is fixed at 90 feet (27 meters), which is aimed at Europe. Thus, in the European direction, full stacking is available; in all other directions the top beam can be used alone. Moreover, it is easy to excite both beams and activate two azimuthal directions simultaneously, or it is also possible to switch instantly from one direction to another without losing the normal time to turn the large Yagi antenna.

*For certain point-to-point communications, where the path conditions are marginal, the increased gain from lateral stacking could outweigh the nuisance of the narrower azimuthal angle.

I have found the flexibility of this system to be very helpful in many situations.

antenna excitation

My second observation is that, for all types of stacked arrays, I have found it useful to provide a switching system that allows operation of each Yagi independently or both together. When only high-angle radiation is desired, the lower antenna is usually best. For lower angles of radiation, the combined stack is better. It is easy to arrange such a switch using conventional relays and quarter-wave coaxial transformers; a practical system is shown in fig. 1 for two stacked Yagi antennas.

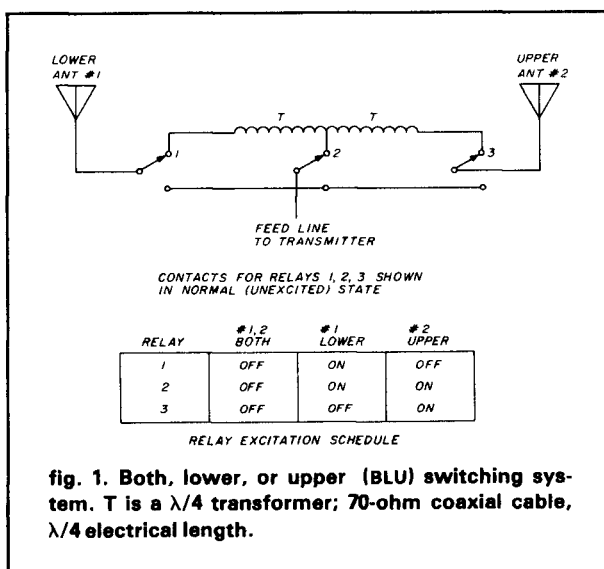

fig. 1. Both, lower, or upper (BLU) switching system. T is a $\lambda/4$ transformer; 70-ohm coaxial cable, $\lambda/4$ electrical length.

The relays may have to be compensated by small shunt capacitors if their series inductance is too large. The relay box should be mounted on the mast about half way between the Yagi antennas. Extension to more than two stacked Yagi antennas is equivalently easy. However, the particular scheme will depend on the way in which power is to be split between all Yagi antennas.

Because of these various excitation techniques, it is desirable to compute not only the properties of a vertically stacked Yagi system, but the properties of the individually excited Yagi antennas.

Two complicating problems arise. First, not only is a single Yagi antenna over ideal ground *not* the same antenna as in free space,¹ but it is further changed by all other Yagi antennas as well as their ground images. This is true even if all other Yagi antennas are not driven. To some extent their elements will be parasitically excited by the single driven Yagi antenna.

This means that the computation for a single Yagi must be carefully made to account fully for all the parasites and images in its local field. Second, if only

table 1. Representative good Yagi beams. All elements are cylindrical with radius $\rho = 0.0005260(\lambda)$.

element	3-elements 0.25 (λ) boom length		6-elements 0.75 (λ) boom length	
	length (λ)	boom position (λ)	length (λ)	boom position (λ)
reflector driven	0.49801	0.000	0.49528	0.000
D1	0.48963	0.150	0.48028	0.150
D2	0.46900	0.300	0.44811	0.300
D3			0.44811	0.450
D4			0.44811	0.600
			0.44811	0.750

the top Yagi is rotatable, the performance of the single lower antenna alone will depend on the relative azimuthal orientation of the two antennas. In this case it is instructive to compute three cases: parallel, orthogonal, and antiparallel orientations.

stacking arrangements

Let us now choose some representative horizontally polarized stacking arrangements over flat, ideal, ground and compute their theoretical performance. I shall present computed H-plane patterns over the range of elevation angles of interest.

The E-plane pattern over ideal ground is, of course, zero everywhere. System forward gain at central design frequency is shown (from zero to 20 dBi) as a function of elevation angle (from zero to 60 degrees). The plots show not only how well the overall system performs at the important low angles, but also what may be sacrificed at the higher angles, which are occasionally useful.

Two basic Yagi designs are used. They are the same three-element beam ($boom = 0.25 \lambda$) and the same six-element beam ($boom = 0.75 \lambda$) shown in table 1 of the previous article.¹ They are reproduced

for convenience in table 1.

I shall start with two stacked, identical beams over ground. In practice, the height of the upper beam will be fixed at the overall mast height. The placement of the lower antenna will be made at some lower position. It is interesting to understand the tradeoffs involved in the height of the lower antenna.

antenna patterns

I shall choose, for illustrative purposes, four different heights, HU , for the upper beam (assumed to be the supporting mast height). For each of these cases, three different heights, HL , for the lower beam are chosen. All heights are expressed in wavelengths (λ) at the central design frequency.

Tables 2 and 3 show computed results for all these cases. These tables also refer to figs. 2 and 3, which display detailed H-plane patterns for all cases.

Note that each figure has several graphs: one for the combined stacked performance (labeled 1); one for the lower antenna alone (labeled 2); one for the upper antenna alone (labeled 3); and, where applicable, what the lower antenna only would show if no upper antenna were physically present (labeled 4).

In cases 2 and 3, both antennas are physically present, but only one is driven (all nondriven elements act as parasites). I have assumed, in these calculations, that the unused driven elements are sufficiently detuned so that they play no part in overall performance.

An examination of tables 2 and 3, and especially the H-plane patterns of figs. 2 and 3, reveals a number of interesting and important characteristics of these simple, vertically stacked systems. Table 2 shows the maximum gain and corresponding elevation angle for each case of a stacked pair of 3-element beams. Also shown is the F/B ratio, which we now know varies with the exact element complex current(s), which in turn are influenced by the mutual

table 2. Gain in dBi of a 3-element stack, upper height $HU(\lambda)$ and lower height $LU(\lambda)$.

fig. no.	both		lower			upper			lower only					
	HL	HU	max. gain	angle (degrees)	F/B (dB)	max. gain	angle (degrees)	F/B (dB)	max. gain	angle (degrees)	F/B (dB)			
2A	0.30	0.75	14.42	21	24.34	11.48	33	19.72	13.96	19	21.83	11.74	36	19.50
2B	0.375	0.75	14.50	21	23.84	11.78	33	21.70	13.59	18	23.25	12.38	32	21.76
2C	0.45	0.75	14.55	21	21.81	11.83	34	25.81	12.90	18	26.23	12.96	29	23.06
2D	0.60	1.50	15.82	11	32.28	13.69	20	30.21	14.77	10	27.92	13.87	23	31.33
2E	0.75	1.50	16.56	11	21.14	14.51	16	23.97	15.19	10	22.28	14.07	18	21.21
2F	0.90	1.50	16.71	11	21.84	14.53	15	20.84	14.89	10	20.91	14.14	16	19.08
2G	0.90	2.25	15.61	8	17.78	14.32	16	20.00	14.30	6	20.21	14.14	16	19.08
2H	1.125	2.25	16.33	8	19.08	14.32	13	23.06	14.36	6	18.65	14.32	13	25.98
2I	1.35	2.25	16.99	7	17.19	14.62	10	17.49	14.77	6	18.23	14.35	11	19.48
2J	1.00	3.00	15.19	6	20.24	14.19	14	19.28	14.50	5	20.24	14.24	14	20.07
2K	1.50	3.00	16.32	6	18.80	14.38	10	19.84	14.41	5	19.28	14.38	9	19.78
2L	2.00	3.00	17.11	5	18.79	14.56	7	19.04	14.60	5	18.93	14.46	7	19.86

table 3. Gain in dBi of a 6-element stack, upper height $HU(\lambda)$ and lower height $LU(\lambda)$.

fig. no.	both			lower			upper			lower only				
	HL	HU	max. gain (degrees) (dB)	angle (degrees)	F/B (dB)	max. gain (degrees) (dB)	angle (degrees)	F/B (dB)	max. gain (degrees) (dB)	angle (degrees)	F/B (dB)	max. gain (degrees) (dB)	angle (degrees)	F/B (dB)
3A	0.30	0.75	15.22	20	24.23	13.46	44	9.57	15.08	17	23.13	13.40	30	17.14
3B	0.375	0.75	15.61	20	21.00	13.70	43	9.75	14.47	16	19.21	13.97	27	23.57
3C	0.45	0.75	15.63	19	18.85	13.51	43	8.87	13.45	16	14.10	14.52	25	29.80
3D	0.60	1.50	17.47	11	22.71	15.09	21	21.88	16.43	9	30.72	15.18	21	24.19
3E	0.75	1.50	17.28	11	14.07	15.16	20	18.50	15.74	9	18.11	15.59	18	21.52
3F	0.90	1.50	18.09	11	23.48	15.74	16	36.08	16.06	9	24.17	16.16	15	28.57
3G	0.90	2.25	18.00	8	30.06	15.94	14	26.76	16.73	6	44.62	16.16	15	28.57
3H	1.125	2.25	18.41	8	28.56	16.39	12	48.07	16.56	6	30.48	16.31	12	34.93
3I	1.35	2.25	18.60	7	19.87	16.26	11	22.61	16.36	6	21.58	16.38	10	31.95
3J	1.00	3.00	17.33	6	38.94	16.49	14	33.55	16.62	5	40.44	16.36	14	35.77
3K	1.50	3.00	18.70	6	32.04	16.61	9	36.88	16.80	5	35.32	16.58	9	38.61
3L	2.00	3.00	19.23	5	25.19	16.79	7	26.65	16.82	5	25.86	16.67	7	40.94

impedances to all other elements. Table 3 shows the equivalent quantities for the stacked pair of 6-element beams.

Note from these tables that the smaller values of overall antenna mast height, HU , do not give as much overall maximum gain as the higher antennas; this gain deficit is more severe for the 6-element beams than for the 3-element beams. This is the same general result previously obtained for single antennas over ground;¹ it results from the same phenomenon; that is, the natural increased free space directivity of the larger Yagi antennas reduces the gain potential at the higher elevation angles required for the lower antennas.

Note also from these tables that the exact placement of the lower Yagi antenna does not markedly influence the stacked maximum gain of the system but usually does significantly affect the angle of the lower antenna radiation. Note also that the excellent free space F/B ratio can be significantly affected by stacking; it is most strongly affected when the stack spacing is small and where the number of (adjacent) parasites is large, for example, especially the first three cases in table 3.

To properly assess all of these stacked Yagi antenna systems, it is necessary to look at the H-plane (elevation angle) patterns shown in figs. 2 and 3. It is instantly clear that excellent stacked coverage (curve 1) of the crucially important 0-20 degree elevation angles requires a reasonably high system ($HU = 1.0\lambda$) but not too high ($HU = 2.5\lambda$). Above the first main lobe of radiation the patterns are quite varied; it is helpful to understand the basic reasons for these variations. Fig. 4 shows a simplified sketch of the two Yagi antennas above ground, each one represented on this diagram by a point. The lower antenna is at a height HL (in λ) and the upper one is at a height HU (in λ); also shown are the image antennas below ground at heights of $-HU$ and $-HL$, respectively.

Note that at an elevation angle, θ , the radiation from the lower antenna lags that from the upper antenna by a distance $(HU - HL) \cdot \sin\theta$ (also in λ). This phase lag causes the pair of antennas to interfere both constructively and destructively. At certain values of θ , which I shall designate θ_p , destructive interference will be complete and produce a radiation pattern null. Since the phase lag between the two antennas above ground is identical to that between the two images below ground, the overall radiation will also show these nulls where

$$\theta_p = \sin^{-1} [(N + 1/2)/(HU - HL)] \quad (1)$$

where N can take on integer values starting with zero (0, 1, 2, ...).

Now, from fig. 4, note that the radiation from the image pair (which is excited out of phase with the real antenna pair) further lags by a distance $(HU + HL) \cdot \sin\theta$. Thus nulls will also occur in the overall pattern due to ground reflections at values of θ which I shall designate as θ_G where:

$$\theta_G = \sin^{-1} [M/(HU + HL)] \quad (2)$$

where M can assume integral values (0, 1, 2, ...).

As an example, consider fig. 3L where $HU = 3.00\lambda$ and $HL = 2.00\lambda$. Eqs. 1 and 2 predict that nulls should occur (in the range 0 to 60 degrees shown) as follows:

$$\begin{aligned} \theta_p &= 30 \text{ degrees} \\ \theta_G &= 11.5 \text{ degrees, } 23.6 \text{ degrees,} \\ &\quad 36.9 \text{ degrees, } 53.1 \text{ degrees} \end{aligned}$$

While fig. 3L, which shows gain only above 0 dBi, only suggests these minima, the full calculations show them all quite clearly. Moreover, note from fig. 3L that the upper envelope of gain falls off substantially with azimuthal angle; this general result is caused

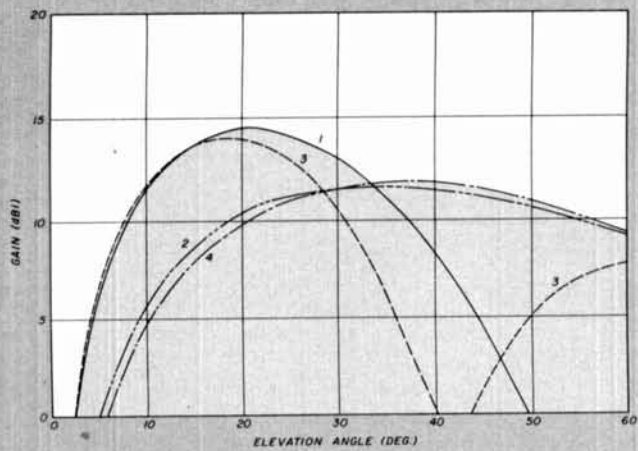

fig. 2A. Gain of a 3-element stack. Curve 1 — both, 2 — lower, 3 — upper, 4 — lower only (upper physically absent).

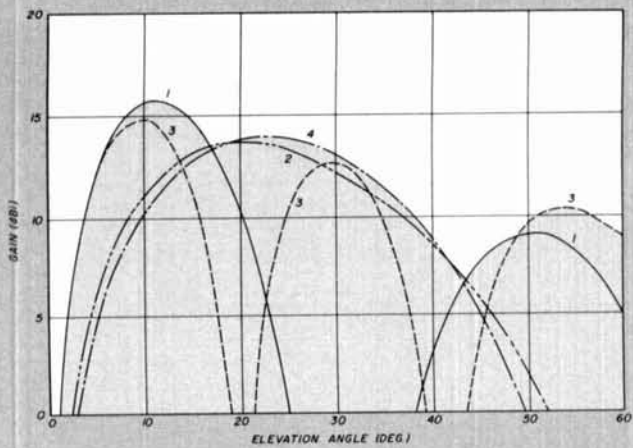

fig. 2D. Gain of a 3-element stack. Curve 1 — both, 2 — lower, 3 — upper, 4 — lower only (upper physically absent).

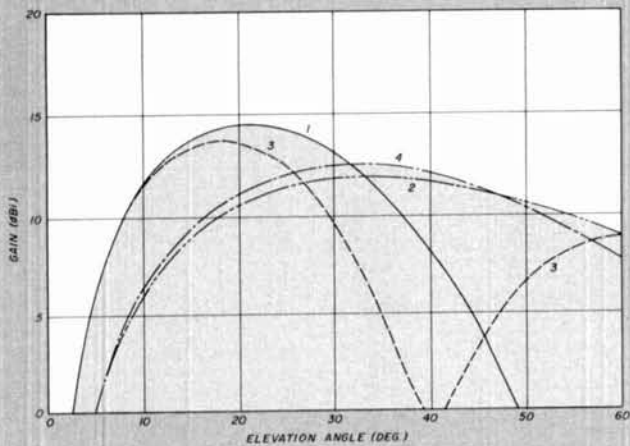

fig. 2B. Gain of a 3-element stack. Curve 1 — both, 2 — lower, 3 — upper, 4 — lower only (upper physically absent).

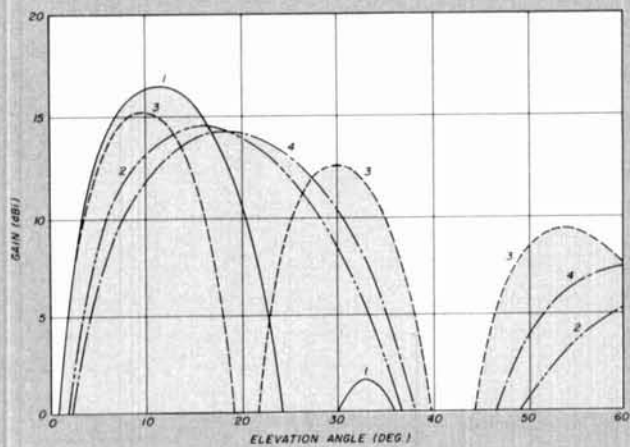

fig. 2E. Gain of a 3-element stack. Curve 1 — both, 2 — lower, 3 — upper, 4 — lower only (upper physically absent).

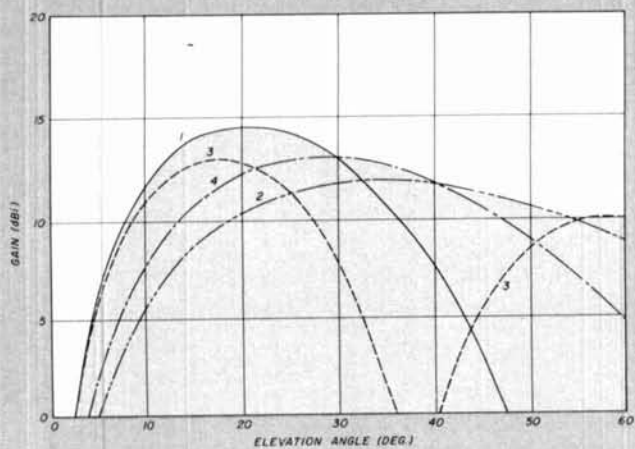

fig. 2C. Gain of a 3-element stack. Curve 1 — both, 2 — lower, 3 — upper, 4 — lower only (upper physically absent).

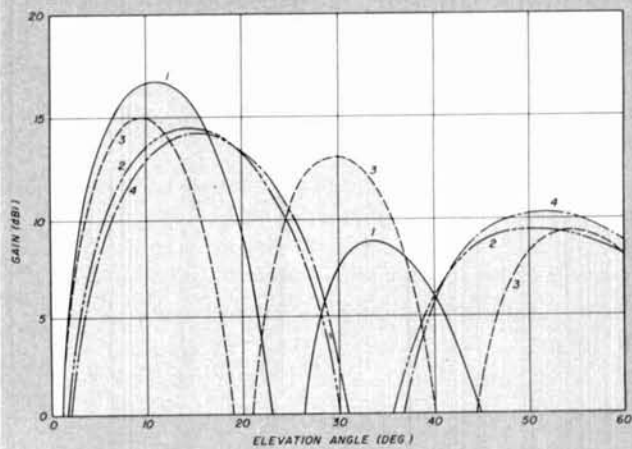

fig. 2F. Gain of a 3-element stack. Curve 1 — both, 2 — lower, 3 — upper, 4 — lower only (upper physically absent).

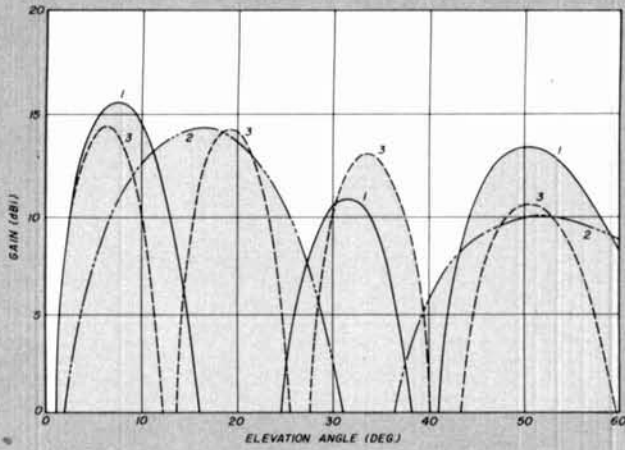

fig. 2G. Gain of a 3-element stack. Curve 1 – both, 2 – lower, 3 – upper.

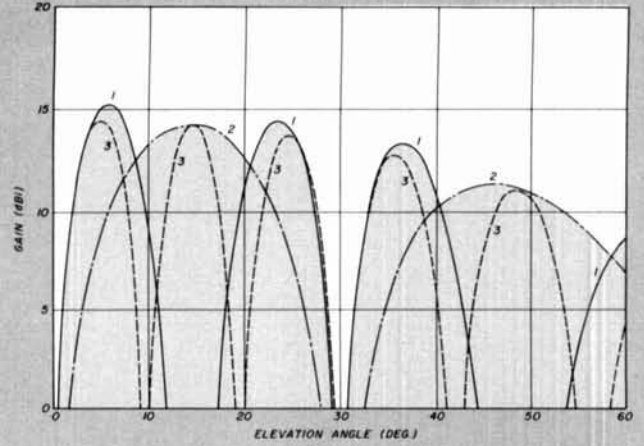

fig. 2J. Gain of a 3-element stack. Curve 1 – both, 2 – lower, 3 – upper.

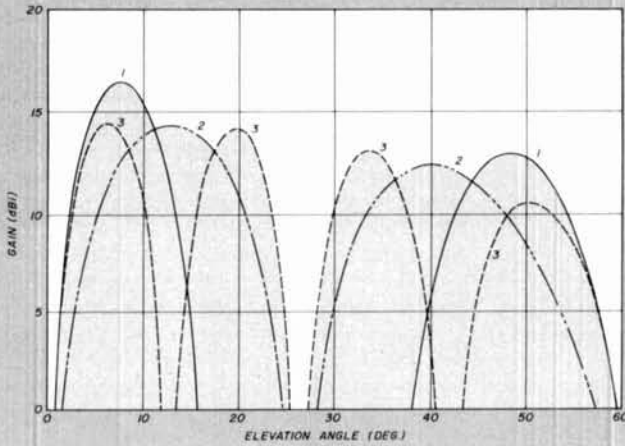

fig. 2H. Gain of a 3-element stack. Curve 1 – both, 2 – lower, 3 – upper, 4 – lower only (upper physically absent).

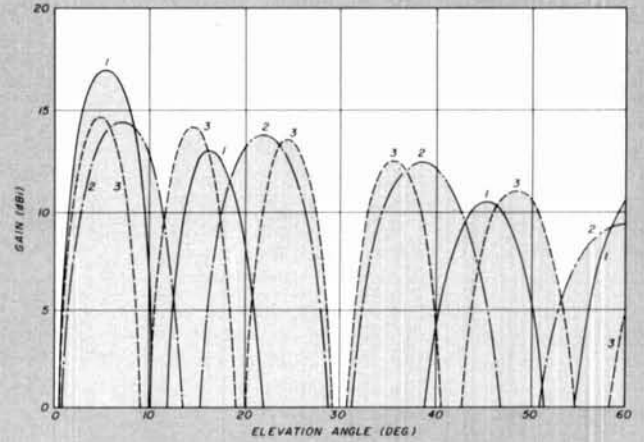

fig. 2K. Gain of a 3-element stack. Curve 1 – both, 2 – lower, 3 – upper, 4 – lower only (upper physically absent).

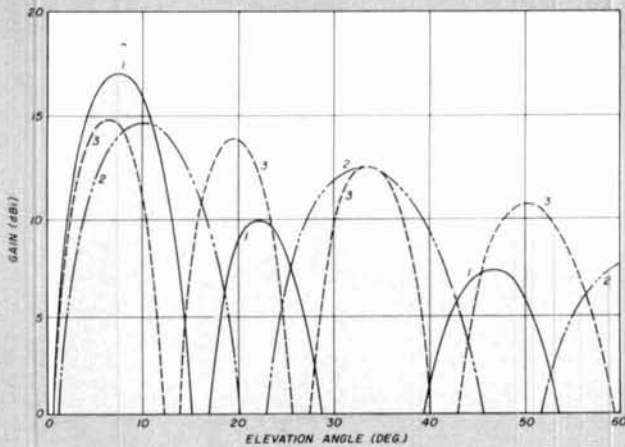

fig. 2I. Gain of a 3-element stack. Curve 1 – both, 2 – lower, 3 – upper, 4 – lower only (upper physically absent).

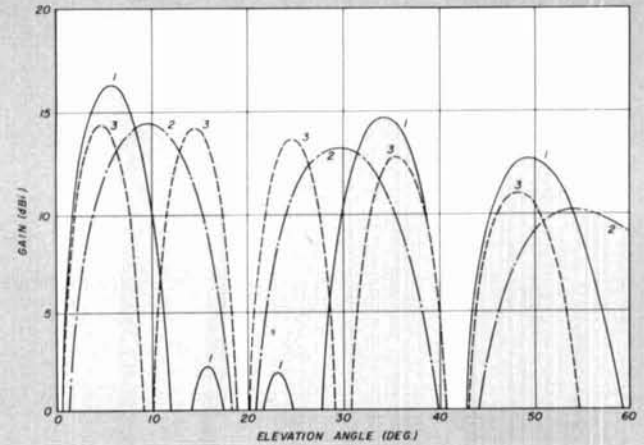

fig. 2L. Gain of a 3-element stack. Curve 1 – both, 2 – lower, 3 – upper, 4 – upper only (upper physically absent).

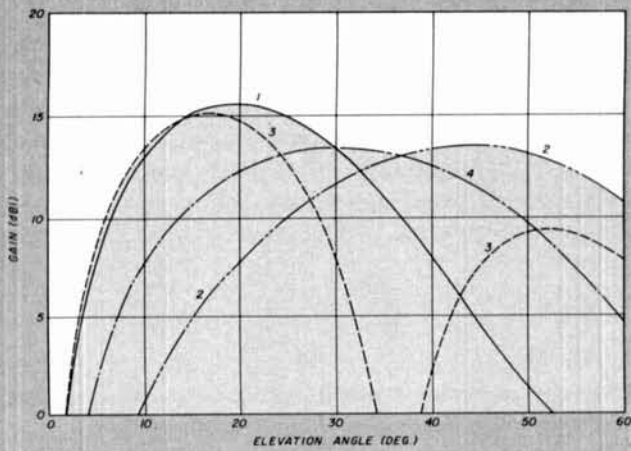

fig. 3A. Gain of a 6-element stack. Curve 1 — both, 2 — lower, 3 — upper, 4 — lower only (upper physically absent).

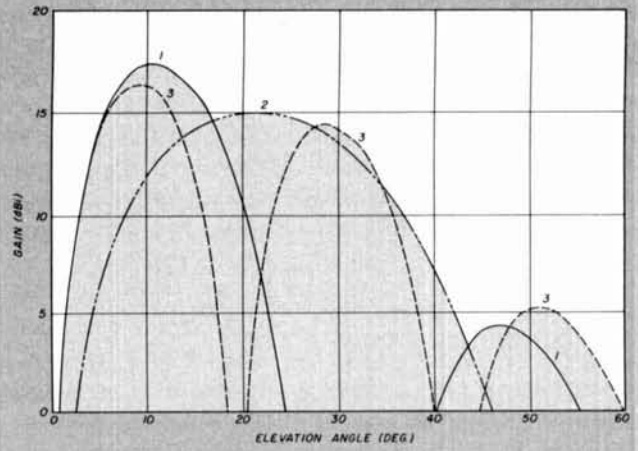

fig. 3D. Gain of a 6-element stack. Curve 1 — both, 2 — lower, 3 — upper.

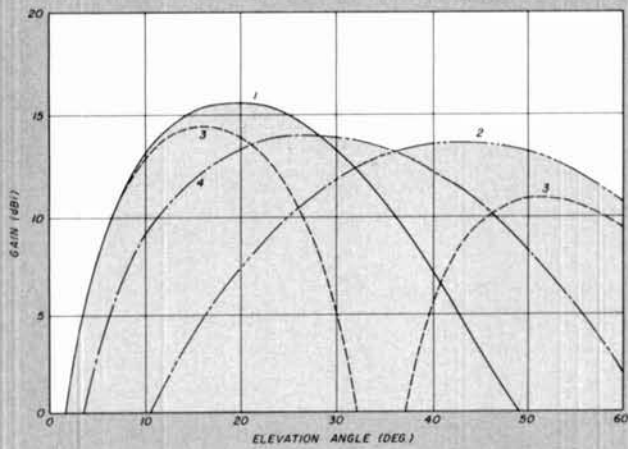

fig. 3B. Gain of a 6-element stack. Curve 1 — both, 2 — lower, 3 — upper, 4 — lower only (upper physically absent).

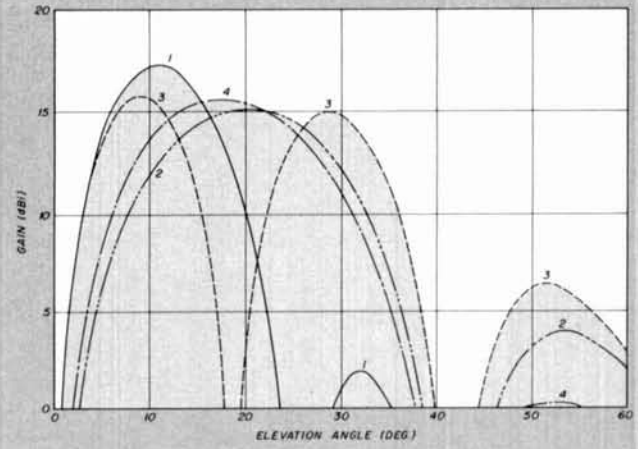

fig. 3E. Gain of a 6-element stack. Curve 1 — both, 2 — lower, 3 — upper, 4 — lower only (upper physically absent).

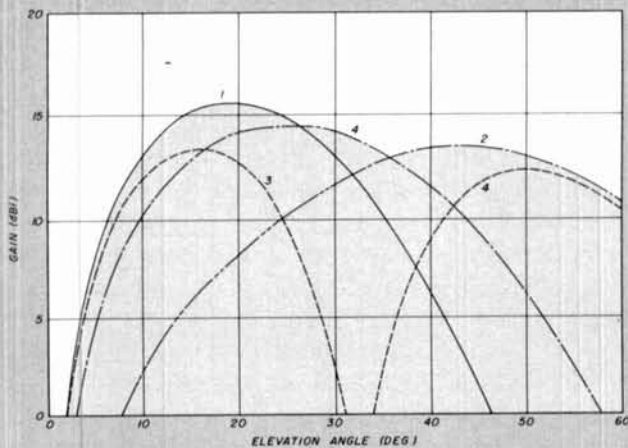

fig. 3C. Gain of a 6-element stack. Curve 1 — both, 2 — lower, 3 — upper, 4 — lower only (upper physically absent).

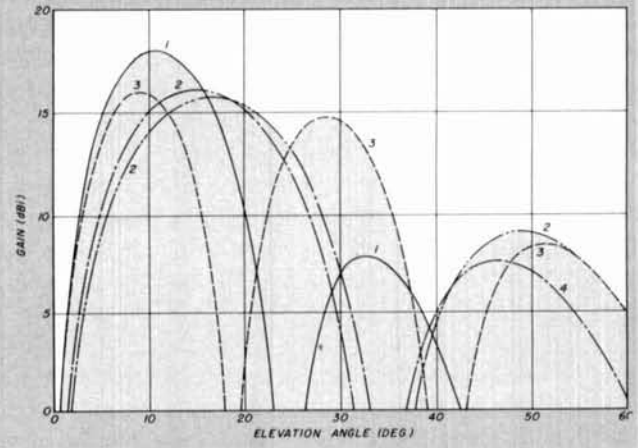

fig. 3F. Gain of a 6-element stack. Curve 1 — both, 2 — lower, 3 — upper, 4 — lower only (upper physically absent).

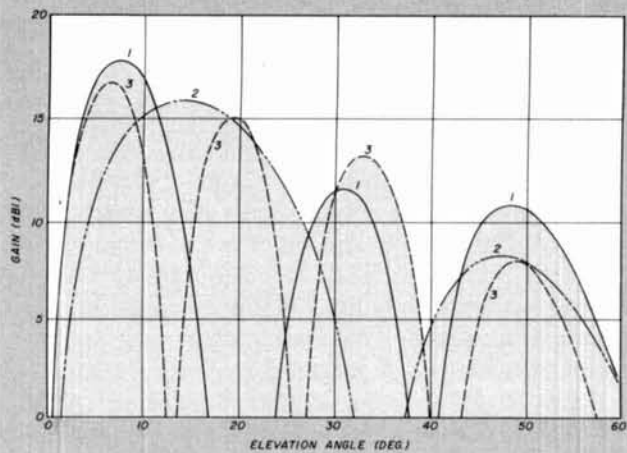

fig. 3G. Gain of a 6-element stack. Curve 1 – both, 2 – lower, 3 – upper, 4 – lower only (upper physically absent).

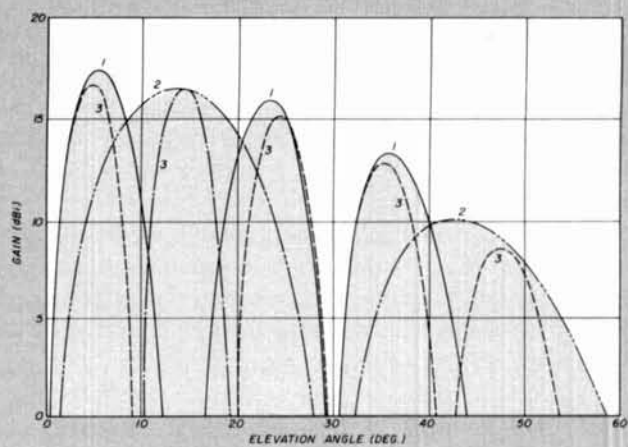

fig. 3J. Gain of a 6-element stack. Curve 1 – both, 2 – lower, 3 – upper, 4 – lower only (upper physically absent).

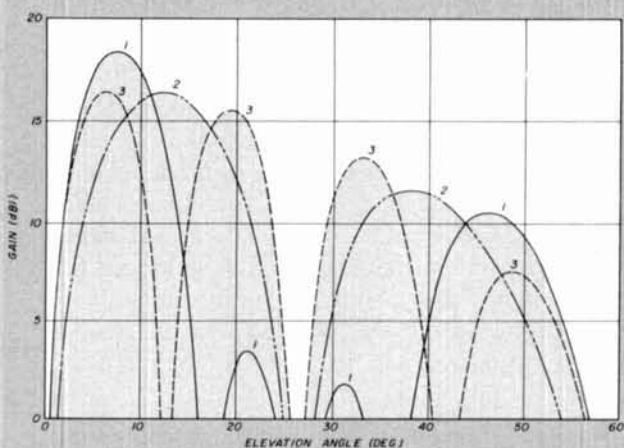

fig. 3H. Gain of a 6-element stack. Curve 1 – both, 2 – lower, 3 – upper, 4 – lower only (upper physically absent).

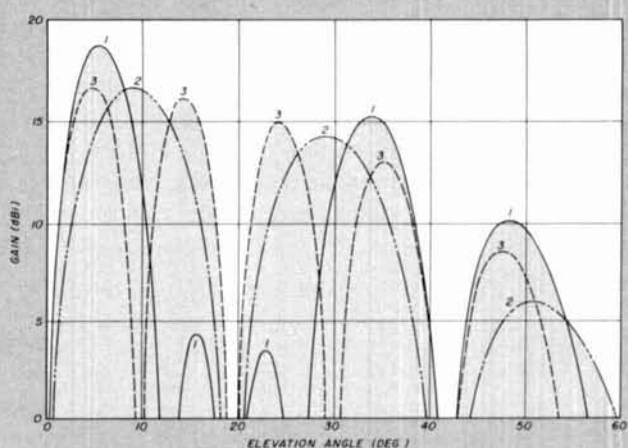

fig. 3K. Gain of a 6-element stack. Curve 1 – both, 2 – lower, 3 – upper, 4 – lower only (upper physically absent).

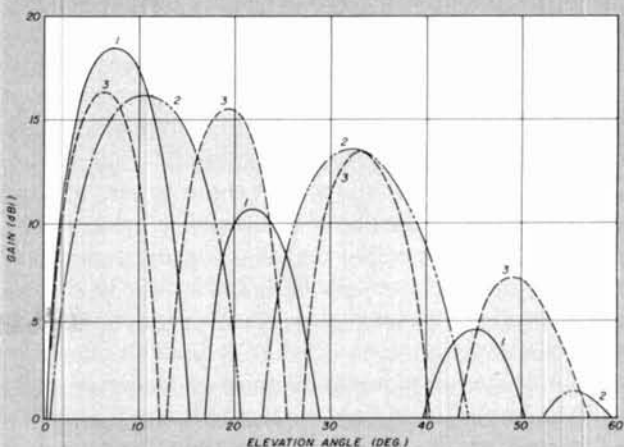

fig. 3I. Gain of a 6-element stack. Curve 1 – both, 2 – lower, 3 – upper, 4 – lower only (upper physically absent).

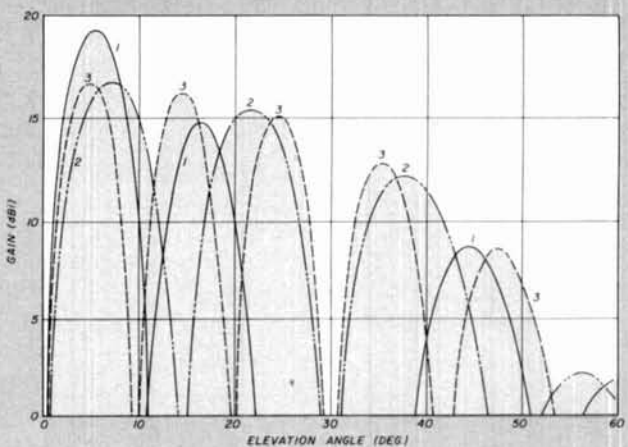

fig. 3L. Gain of a 6-element stack. Curve 1 – both, 2 – lower, 3 – upper, 4 – lower only (upper physically absent).

by the natural free space directivity of the individual Yagi antennas. Note that this effect is much more pronounced for the larger 6-element Yagi antennas (fig. 3L) than for the smaller 3-element equivalent stack (fig. 2L).

Thus, the overall H-plane pattern is the result of three effects: first, the natural free-space directivity of the individual Yagi antennas; second, the interference effect of the two real antennas; and third, the interference effect of the above ground system with its image counterpart. All three effects have different angular dependences; it is therefore not surprising that the overall resultant can be quite varied and complex.

For those readers interested in constructing a vertically stacked Yagi antenna array, a careful scrutiny of tables 2 and 3 and especially all of the relevant figures is quite enlightening. It is apparent that there is no single ideal design; nevertheless, there are a number of salient points that are worth noting.

1. A mast height (upper antenna height) of 0.75λ is really not high enough to get very much additional gain from stacking, especially with large Yagi antennas.

2. The higher systems provide better low-angle performance than the lower systems but sacrifice (sometimes needed) high-angle performance. They also provide less gain sacrifice due to ground images for big antennas and through increased antenna spacing provide less spoiling of the inherently good individual Yagi free-space characteristics.

3. The important (lowest) first-lobe gain is only weakly dependent on the placement of the lower antenna. The gain alone would favor HL somewhat above $HU/2$ (see for example figs. 3G, 3H, and 3I); nevertheless, a lower placement (wider element spacing) will result in smaller beam interactions.

4. Mutual coupling or interaction between Yagi antennas tends to spoil the otherwise excellent properties of a single Yagi. This spoiling is most pronounced for low systems where spacings are small, not only to ground but between Yagi antennas (see for example figs. 2A, 2B, and 2C). This spoiling can be easily seen in the altered pattern(s) of the lower beam (curve 2) when the upper beam is physically present and (curve 4) when the upper beam is absent. You can also see the effect that stacking has on the F/B ratios (tables 2 and 3) and also (not shown) the effects on the calculated driving point impedances of both upper and lower Yagi antennas.

5. Interactive effects are also more serious when large Yagi antennas are used. This general result is anticipated and is due to the larger number of adja-

cent parasites; it is illustrated by comparing curves 2 and 4 of figs. 2B and 2C with those of figs. 3B and 3C.

6. Any good (reasonably high) stacked array will benefit by the *Both, Lower, Upper* or BLU switch arrangement (see figs. 3G and 1) where at high angles a fill in the performance can be made (usually) using the lower antenna only. Best higher angle fill occurs when the placement of the lower antenna is at or preferably below $HU/2$. A good practical height is $HU/3 > HL > HU/2$. Note that a good fill obtained in this way slightly compromises maximum gain; however, this compromise is really not very serious.

7. With the BLU switch available it is interesting to compare performances. In all cases, at the very lowest angles, B and U give essentially identical results, that is, the stack is just as good as the upper antenna alone. However, the stack always accepts a broader range of vertical angles in its first lobe (due to its lower average height) and at its peak has more gain than either upper or lower alone. This gain advantage is one to three dB depending on the particular stack. Although this may not seem very impressive, experience demonstrates that the stack does indeed provide a commanding performance advantage over a single Yagi antenna and, coupled with the broader vertical coverage of the first lobe, will be more consistent.

8. A number of excellent stacked arrays can be chosen from these figures. As a good example note fig. 3D. I have operated a stack very much like this on 14 MHz for several years; experience shows this to be a superb performer even without a BLU switch arrangement. Figs. 3E and 3F also look very attractive, but the closer beam spacing results in increased variations in F/B properties and probably would require a BLU switch for best high-angle fill. For a higher stack note the excellent gain performances of figs. 3G through 3I. However, for any of these cases, a fill seems desirable by the use of a BLU switch; note that for best fill at some higher angles the *upper* antenna should be used. For a very high stack fig. 3J provides exceptional stacked gain, and by the additional use of the lower antenna (for fill), it accommodates radiation angles up to nearly 30 degrees. However, at the 30 degree angle the system performance is abysmal, giving essentially zero response for any setting of the BLU switch.

electrically derived fill

I shall now turn briefly to an alternative method of obtaining higher-angle fill, a method that promises to be operationally simple and potentially very effective. Up to this point, I have used identical driver currents

table 4. Performance of stack shown in fig. 3D vs. relative phase angle, ϕ , of lower-to-upper drive current. Gain is in dBi, elevation angle in degrees, F/B in dB, R and X in ohms, and ϕ in degrees.

phase ϕ	maximum elevation			impedance	
	gain	angle	F/B	R	X
0	17.47	11	22.71	21.96	-1.22
45	16.95	11	23.53	21.96	-1.09
60	16.47	11	23.80	21.94	-1.05
90	15.00	10	24.45	21.88	-0.99
120	15.81	28	21.46	21.79	-0.98
135	16.43	28	22.41	21.75	-0.99
180	17.26	28	25.33	21.65	-1.07
-45	16.74	11	21.80	21.86	-1.30
-90	14.53	28	37.64	21.73	-1.30
-135	16.69	28	29.43	21.65	-1.20

in both magnitude and phase. Let us now consider what effect is made on (stacked) H-plane patterns if the phase of the drive current in the lower antenna is changed relative to that in the upper antenna. I shall use as a test case the stack of 3D and will change the relative phase angle, ϕ , of the lower antenna drive current with respect to that of the upper antenna drive current. Computation of system performance under these conditions exhibits some remarkable effects. Table 4 shows performance as a function of ϕ (in degrees) for several discrete relative phase angles from zero to 180 degrees, and fig. 5 shows the H-plane patterns corresponding to selected values of ϕ .

The H-plane pattern for any positive value of ϕ is nearly identical to the pattern for the same negative value of ϕ ; minor differences (which are also evident

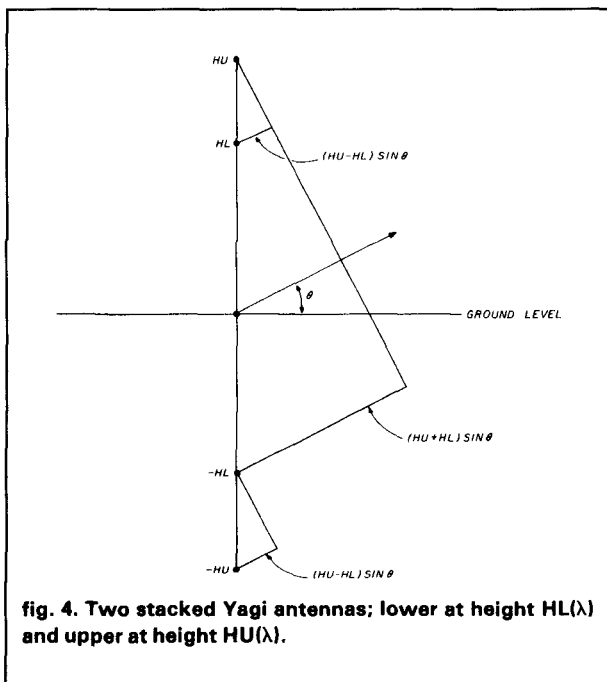

fig. 4. Two stacked Yagi antennas; lower at height HL(λ) and upper at height HU(λ).

in table 4) are caused by the detailed way in which all mutual coupling effects take place. It is easy to see from fig. 5 that reversing the phase ($\phi = 180$ degrees) results in excellent system performance at higher angles; basically giving maxima where the original H-plane pattern showed minima. At intermediate values of ϕ an intermediate result is obtained where the resulting H-plane pattern is a combination of both the $\phi = 0$ degrees (original pattern) and the $\phi = 180$ degrees (out-of-phase pattern). Note that this higher angle fill effectively uses the extra gain potential of both Yagi antennas; it is therefore potentially superior to a single Yagi antenna fill and is also quite easy to implement (by switching in to only one of the antennas a coaxial line whose electrical length is $\lambda/2$).

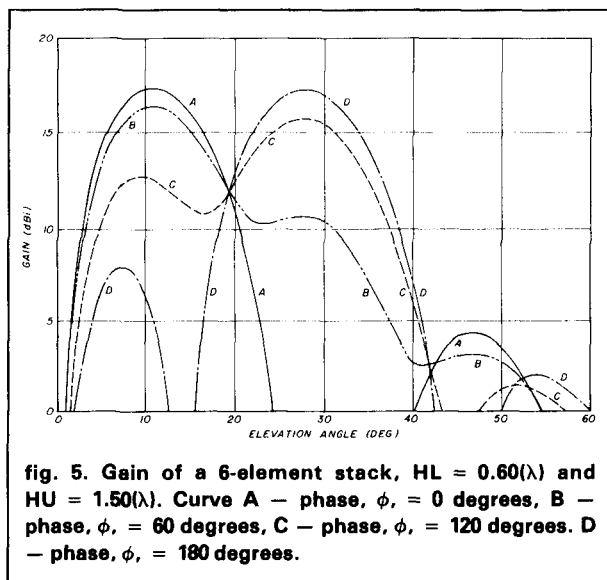

fig. 5. Gain of a 6-element stack, HL = 0.60(λ) and HU = 1.50(λ). Curve A — phase, ϕ , = 0 degrees, B — phase, ϕ , = 60 degrees, C — phase, ϕ , = 120 degrees. D — phase, ϕ , = 180 degrees.

One can also see clearly from fig. 5 that if ϕ is relatively small little degradation of system performance occurs; this fact potentially allows the stacking of dissimilar Yagi antennas. Nevertheless the use of dissimilar antennas raises questions about how to measure the effective ϕ and certainly increases the complications of controlling ϕ over a reasonable bandwidth of frequencies.

It is important to note that only two values of ϕ are desired. The in-phase case ($\phi = 0$ degrees) is best for low-angle performance and the out-of-phase ($\phi = 180$ degrees) is best for higher values of elevation angle. All other values of ϕ give inferior results to either one or the other of these cases.

more than two antenna arrays

Let me now consider the possibility of stacking

table 5. Gain of multi 6-element stacks, lowest at height $H1(\lambda)$ and next at $H2(\lambda)$, etc. Gain is in dBi.

fig. no.	H1	H2	H3	H4	all			lowest			top			lowest only		
					max. gain	angle (degrees)	F/B (dB)	max. gain	angle (degrees)	F/B (dB)	max. gain	angle (degrees)	F/B (dB)	max. gain	angle (degrees)	F/B (dB)
6	0.75	1.50	2.25		19.14	8	14.81	15.22	20	15.58	16.31	6	22.51	15.59	18	21.52
7	0.75	1.50	2.25	3.00	20.23	6	15.92	15.28	23	16.06	16.22	5	21.04	15.59	18	21.52

more than two Yagi antennas. It is obvious that some additional performance improvement should be possible provided the mast height is sufficiently high. As examples I show computations for two different evenly spaced stacks shown in table 5. The first stack shows three of the 6-element Yagis evenly spaced with a top height of 2.25λ , and the second shows four 6-element Yagis evenly spaced to a top height of 3.0λ . Figs. 6 and 7 show the H-plane patterns for these two systems; they should be compared with figs. 3G and 3J, which are basically equivalent 2-Yagi stacks of comparable mast height. It is at once apparent from fig. 6 that the addition of the third Yagi antenna gives a main lobe gain over fig. 3G of 1.1 dB; all other characteristics are quite comparable. Likewise, fig. 7 shows that the two additional Yagi antennas give a main lobe gain increase of 1.9 dB over fig. 3J; again, all other characteristics are quite similar.

These examples of vertically stacked Yagi antenna arrays using more than two antennas show that a noticeable gain increase is possible over a 2-antenna stack; moreover they open up a wide range of higher-angle fill possibilities. As an example, fig. 7 shows patterns where all four antennas are excited; for fill at higher angles, the lowest antenna (curve 2) and the highest antenna (curve 3) are shown. Note, however, that additional fill situations are possible if two or even three of the original four antennas are excited coherently. Moreover one can also consider feed line phasing(s) for even better fill. Clearly, a host of possibilities exists, but the practical use of all potentially desirable combinations not only requires a complex switching system but a great deal of trouble in determining experimentally the right combination for the prevailing circuit conditions. Surely the additional complexity and expense of these large vertical stacks reaches a point of practical diminishing returns. Nevertheless, how fortunate we are to be able to predict with reasonable confidence the performance of such large systems, without ever having to build one.

I shall conclude this article on stacking by referring again to the basic two-antenna stack shown in fig. 3D. Note that the F/B performance has deteriorated from the excellent free-space performance of the individual Yagi antennas of 48 dB to 22.7 dB. Analogous to the optimization of a single Yagi antenna over ground,¹ it is possible to optimize the basic Yagi de-

table 6. Specifications for 6-element beams optimized by slight shifts in boom positions for D1 and D3. All element radii are $0.0005260(\lambda)$.

element	optimized for free space		optimized for stack fig. 3D	
	length (λ)	boom position (λ)	length (λ)	boom position (λ)
reflector driven	0.49528	0.000	0.49528	0.000
D1	0.48071	0.150	0.48157	0.150
D2	0.44811	0.2991650	0.44811	0.302948
D3	0.44811	0.450	0.44811	0.450
D4	0.44811	0.5999658	0.44811	0.63948
D4	0.44811	0.750	0.44811	0.750

sign for this stacked system. Table 6 shows the optimized parameters of the 6-element Yagi antenna first for free space and second for the stack of fig. 3D ($HL = 0.6\lambda$, $HU = 1.5\lambda$). Tables 7 and 8 show the swept-frequency performance of each of these cases close to the design frequency.

The iterative optimization was carried out by adjustments of the boom positions of D1 and D3 to obtain high F/B (> 90 dB) and by a slight adjustment of driven-element length to minimize reactance at the design frequency. Note again that, because of mutual coupling interactions, the stacked Yagi antenna is not the same Yagi antenna as it would be in free space, nor is it the same Yagi antenna as it would be

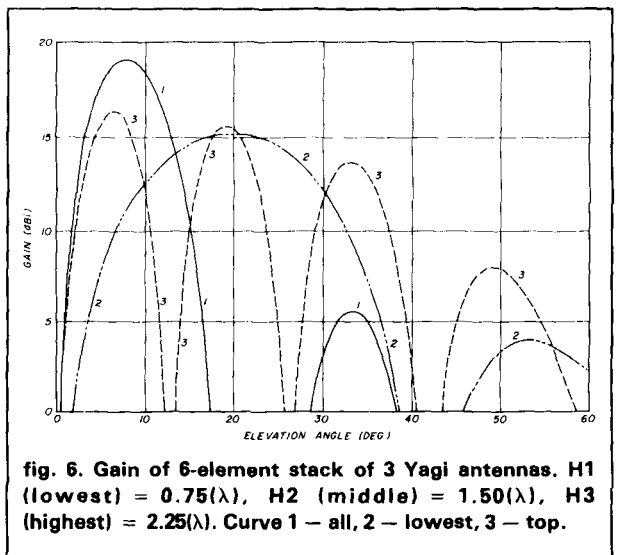

fig. 6. Gain of 6-element stack of 3 Yagi antennas. $H1$ (lowest) = $0.75(\lambda)$, $H2$ (middle) = $1.50(\lambda)$, $H3$ (highest) = $2.25(\lambda)$. Curve 1 - all, 2 - lowest, 3 - top.

table 7. Free-space performance of optimized 6-element Yagi (specification in table 6).

frequency	gain (dBi)	F/B (dB)	angle (deg.)	driver impedance (ohms)	
				R	X
0.996	10.59	26.59	0	22.42	-6.53
0.998	10.65	32.64	0	22.10	-3.50
1.000	10.70	120.18	0	21.80	-0.42
1.002	10.75	32.69	0	21.51	2.72
1.004	10.79	26.68	0	21.25	5.93

table 8. Performance of (fig. 3D) optimized, stacked 6-element Yagi over ground. (Specification in table 6.)

frequency	gain (dBi)	F/B (dB)	angle (deg.)	driver impedance (ohms)	
				R	X
0.996	17.28	24.90	11	16.76	-6.24
0.998	17.35	30.86	11	16.25	-3.14
1.000	17.42	94.69	11	15.75	0.02
1.002	17.48	30.69	11	15.27	3.23
1.004	17.53	24.57	11	14.82	6.50

singly over ground (compare with **table 5** of reference 1).

orthogonal and antiparallel stacked Yagis

Now that an optimized Yagi design has been found, which provides the superlative performance shown in **table 8** when the two stacked antennas are parallel to each other, we can ask about performance degradation when the two Yagi antennas are orthogonal to each other and also when they are antiparallel. This question is relevant when a stack is used where the lower antenna is fixed in some direction and the upper antenna is rotatable. **Table 9** shows the system performance for the case where both Yagis are supported at the center of the boom.

It is clear that, in principle, optimization can be carried out for only one configuration, and performance will automatically deteriorate somewhat for other geometries. The extent of deterioration will be more severe for stacks with small antenna spacings (both with respect to ground and to each other); that is,

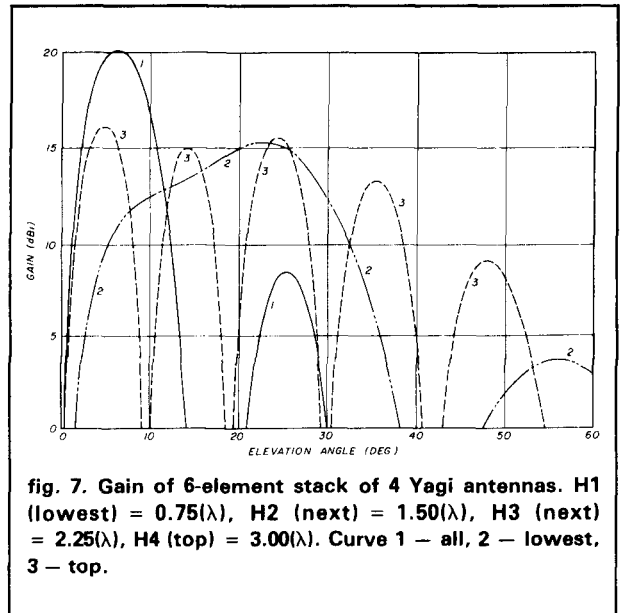

fig. 7. Gain of 6-element stack of 4 Yagi antennas. H1 (lowest) = 0.75(λ), H2 (next) = 1.50(λ), H3 (next) = 2.25(λ), H4 (top) = 3.00(λ). Curve 1 - all, 2 - lowest, 3 - top.

with lower overall mast height. For the stack shown in **table 9**, it is gratifying to see that the performance for all situations is really quite acceptable.

summary

1. Vertical stacking of two Yagi antennas allows both substantial improvement in low-angle system performance and improved flexibility. This flexibility can be used either to obtain fill at some needed higher angles or to illuminate other azimuthal angles (one of two Yagi antennas rotatable).
2. Mast heights of between one and perhaps 2.5 λ can provide excellent 2-Yagi stacked systems.
3. Higher masts favor low-angle radiation and also give smaller mutual interaction effects. However, they also treat the (occasionally useful) higher angles unfavorably.
4. For all vertical stacks, improved performance is available if excitation is switchable to both antennas, *B*, the lower antenna, *L*, or the upper antenna *U* (BLU switch). Switching must be done in a way that preserves phase integrity and keeps the total drive impedance matched to the supply coaxial line. For

table 9. Gain in dBi of a parallel-optimized, stacked 6-element Yagi array showing the alternative configurations.

configuration	both				lower				upper			
	gain (dBi)	F/B (dB)	R (ohms)	X (ohms)	gain (dBi)	F/B (dB)	R (ohms)	X (ohms)	gain (dBi)	F/B (dB)	R (ohms)	X (ohms)
parallel	17.42	94.69	15.75	0.02	15.06	30.34	13.66	-0.41	16.40	25.64	15.59	-0.51
orthogonal					15.15	38.09	14.10	-0.80	16.60	20.86	15.87	-0.82
antiparallel					15.03	31.24	13.63	-0.44	16.43	23.88	15.57	-0.54
angle (deg.)			11				21				9	

State
of the art



by
K.V.G.

XF-910

Introducing the new 2-pole 9 MHz Crystal Filter.

The XF-910 crystal filter has been designed for use in modern receiver IF systems using I.C. amplifiers. It is used between the IF amplifier and detector stages to suppress wideband I.C. noise and prevent noise overload of the detector.



The XF910 can also be used in place of ceramic filters and tuned circuits in simple receivers when superior selectivity of the XF9-B is not required, Price \$16.35 plus shipping.

SPECIFICATION XF910:

Center Frequency	9.0 MHz	Ultimate attenuation	> 40.0 dB
Bandwidth	15.0 kHz	Terminations:	6000 ohms
Passband Ripple	< 1.0 dB		zero pF
Insertion Loss	< 0.5 dB	Mechanical	3-lead Hc18/u can

1296 MHz EQUIPMENT

Announcing the new 1296 MHz units
by Microwave Modules.



Low Noise RECEIVE Converter MM1296-144
Low Noise RECEIVE Preamplifier MM1296
Low Power LINEAR TRANSVERTER MM1296-144
Plus all our regular 1296 MHz items, antennas, filters, triplers.

TRANSVERTERS FOR ATV OSCARS 7, 8 & PHASE 3

Transverters by Microwave Modules and other manufacturers can convert your existing Low Band rig to operate on the VHF & UHF bands. Models also available for 2M to 70cm and for ATV operators from Ch2/Ch3 to 70cms. Each transverter contains both a Tx up-converter and a Rx down-converter. Write for details of the largest selection available.

Prices start at \$199.95 plus \$3.50 shipping.

SPECIFICATIONS:

Output Power	10 W
Receiver N.F.	3 dB typ.
Receiver Gain	30 dB typ.
Prime Power	12V DC



Attention owners of the original MM1432-28 models: Update your transverter to operate OSCAR 8 & PHASE 3 by adding the 434 to 436 MHz range. Mod kit including full instructions \$26.50 plus \$1.50 shipping, etc.

ANTENNAS (FOB CONCORD, VIA UPS)

144-148 MHz J-SLOTS

8 OVER 8 HORIZONTAL POL.	+ 12.3 dBd	D8/2M	\$55.95
8 BY 8 VERTICAL POL.		D8/2M-VERT.	\$65.60
8 + 8 TWIST		8XY/2M	\$57.75

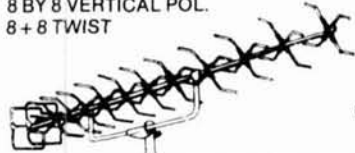

420-450 MHz MULTIBEAMS

For local, DX, OSCAR,
and ATV use.

48 EL.	GAIN + 15.7 dBd	70/MBM48	\$69.95
88 EL.	GAIN + 18.5 dBd	70/MBM88	\$95.95

UHF LOOP YAGIS

28 LOOPS	GAIN + 20 dBi	50-ohm, Type N Connector	
1250-1340 MHz	1296-LY	8 ft. boom	\$59.70
1650-1750 MHz	1691-LY	6 ft. boom	\$64.70

Send 30¢ (2 stamps) for full details of KVG crystal products and all your VHF & UHF equipment requirements.

Pre-Selector Filters	Amplifiers	SSB Transverters	
Varactor Triplers	Crystal Filters	FM Transverters	
Decade Pre-Scalers	Frequency Filters	VHF Converters	
Antennas	Oscillator Crystals	UHF Converters	

si

**Spectrum
International, Inc.**
Post Office Box 1084
Concord, Mass. 01742, USA

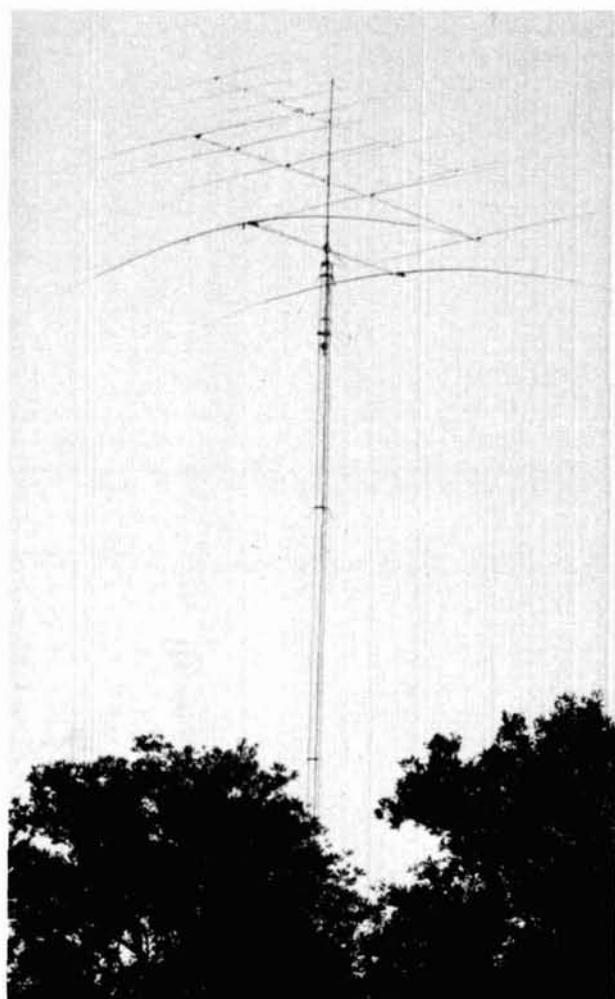

those antenna stacks where the lower and upper beams remain aligned (rotate together), a highly useful switch is a phase reverser to only one of the beams.

5. Vertical stacks using 3 or 4 Yagi antennas can display even greater performance, but the stacks must be very high and must use for best results a more complex feed-line switching arrangement.

6. Optimization (very high F/B at one frequency) can be obtained for only one physical configuration at a time. Nevertheless, there are practical examples where an optimized antenna design for a 2-Yagi stack will still exhibit excellent properties when only the lower antenna or only the upper antenna is excited; moreover, these excellent properties are retained even if the azimuthal directions of the two individual Yagi antennas are parallel, orthogonal or even anti-parallel.

reference

1. J.L. Lawson, "Yagi Antenna Design: Ground or Earth Effects," *ham radio*, October, 1960, page 29.

ham radio

If You Want The Finest

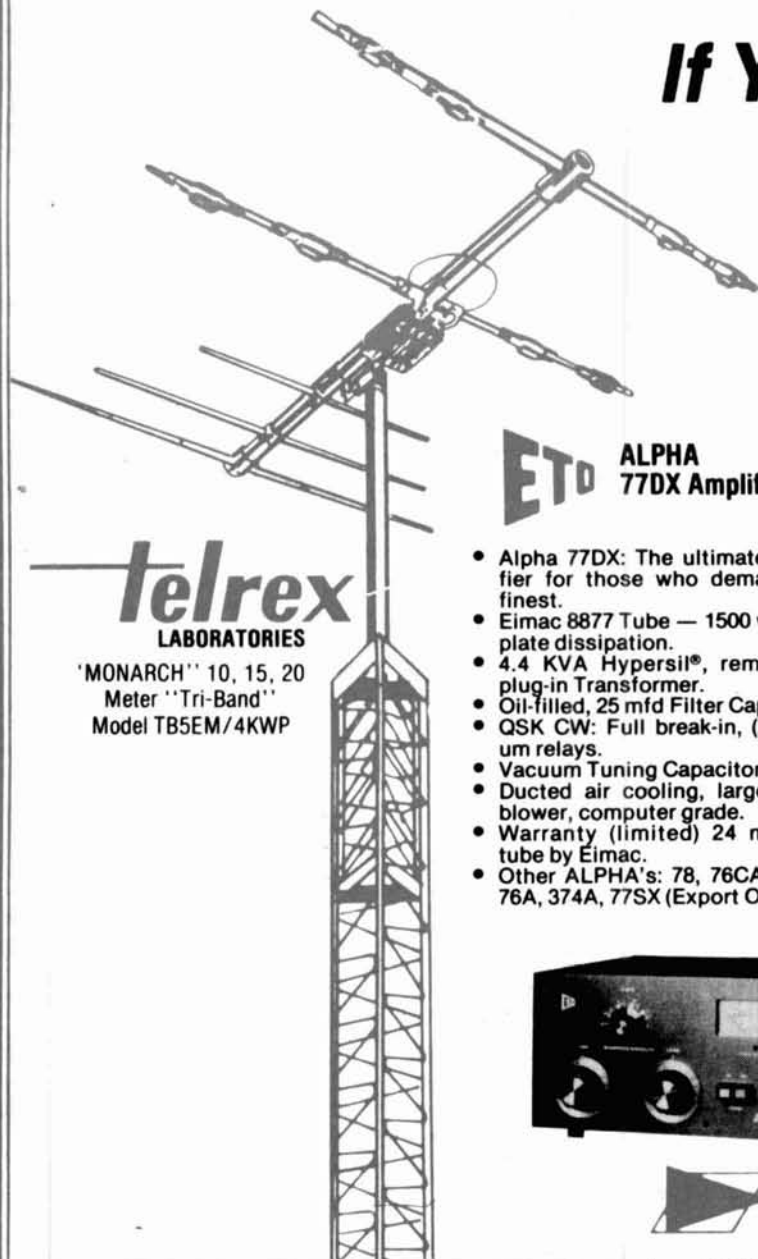

telrex

LABORATORIES

'MONARCH' 10, 15, 20
Meter "Tri-Band"
Model TB5EM/4KWP

ETO

ALPHA 77DX Amplifier

- Alpha 77DX: The ultimate amplifier for those who demand the finest.
- Eimac 8877 Tube — 1500 watts of plate dissipation.
- 4.4 KVA Hypersil®[®], removable, plug-in Transformer.
- Oil-filled, 25 mfd Filter Capacitor.
- QSK CW: Full break-in, (2) vacuum relays.
- Vacuum Tuning Capacitor.
- Ducted air cooling, large, quiet blower, computer grade.
- Warranty (limited) 24 months, tube by Eimac.
- Other ALPHA's: 78, 76CA, 76PA, 76A, 374A, 77SX (Export Only).

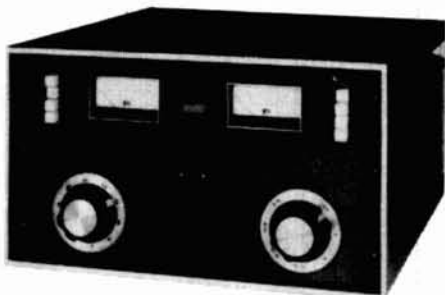

signal/one

CX-11-A Integrated Station



Phone Don Payne, K4ID, for Special Prices, Brochure, and OPERATING EXPERIENCE on the CX-11A and Alphas.

PAYNE RADIO

Personal Phone — (615) 384-2224
P. O. Box 100, Springfield, Tenn. 37172

- **POWER OUTPUT:** 150 watts CW/SSB output all bands (2) MRF 422 Finals.
- **OPTIONAL POWER OUTPUT:** 200 to 225 Watts CW/SSB output
- **SYNTHESIZED FREQUENCY COVERAGE:** All amateur bands 1.8-30 MHz in full 1 MHz bands, plus 4 additional 1 MHz bands for future expansion.
- **TWO PTO'S:** Dual receiving, transceive on either, or split operation.
- **QSK CW;** Full break-in, vacuum relays. 300 Hz CW Filter built-in.
- **SELECTIVITY:** Two 8 pole plus one 4 pole filter deliver 20 pole 1.4:1 shape factor (6dB/60dB), plus post detection 1.5, 1.0, .4 and .1 kHz bandwidth.
- **BUILT-IN A/C supply,** 115/230V, 50/400 Hz, Hypersil® transformer. IF shift, noise blanker, RF clipping, CW keyer, notch/peak filter.
- **SERVICING:** Self service easiest of any transceiver by using gold-plated sockets for transistor and IC replacement.
- **RELIABILITY:** Less than 1% failure. 99% of problems resolved in field.
- **QUALITY:** All military and computer grade. 100% American made.
- **PRICE \$5900,** mfg. by Signal/one Corp., Phoenix, AZ 85021.

crystal use locator

A computer program for matching crystal frequencies to popular Amateur radios

If you're like I am, you have a box full of crystals. They came from scrapped equipment, 5-for-\$1.00 sales that couldn't be passed up, old fm rigs, and abandoned frequencies. I decided that I wanted to find out if the crystals were good for anything in the radios I own. To save a lot of hand calculations I wrote program XLOC. Within XLOC are the crystal formulas for all the radios I own and the frequencies on which these radios can be used. If I type in a crystal frequency, XLOC prints out all the radios in which the crystal is usable and the resulting frequency.

program description

Listing 1 is a sample run of XLOC. After entering the crystal frequency in MHz, XLOC plugs it into the crystal formulas for each radio and checks the result to determine if it's in the specified band for that radio. If one or more of these calculations generates an in-band result, the crystal frequency is printed, followed by pairs of radio descriptions and resulting operating frequencies. If the crystal doesn't produce a valid operating frequency for any of the radios, the message "SORRY!" is printed and XLOC prompts for the next crystal frequency. Entering a 0 in response to the prompt causes XLOC to terminate.

Internally XLOC is straightforward. It's within Technical Systems Consultants' extended BASIC program for the Model 6800 computer.* Looking at listing 2, lines 30 through 100 establish the possible operating frequency ranges for the radios.

Example. Line 40 establishes the frequency range for band 1 to be 28 MHz to 30 MHz. Seven bands are set up in XLOC. To add a new band, just add statements after line 100 to set up new values in the *BS*

and *BE* arrays. For example, to set up a band from 220-225 MHz as band 8 you'd add the statement

$$110 BS(8) = 220:BE(8) = 225$$

Note that *BS* and *BE* are dimensioned at 20. If you want to handle more than 20 bands total, line 30 would have to be changed.

The other information that must be set up is the radio descriptions, the bands on which they operate, and the crystal formulas. Lines 180 through 520 establish the first two. Each string in array *N\$* contains a radio description, and the corresponding element in array *B* contains the number of the band on which it is designed to operate. More radio description/band pairs can be added after line 520. *B* and *N\$* are dimensioned at 20; therefore, the DIM statement at line 180 would have to be changed to handle more than twenty radios.

Logic. Line 660 reads the crystal frequency into variable *X*. Then variable *FD* is set to zero to indicate that no radio requiring this crystal has yet been found. Variable *C* is set to 1 to indicate that we are starting with the first radio. This is used as an index for the *N\$* and *B* arrays. Lines 700 through 1030 consist of pairs of statements. The first statement is the crystal formula for the radio; the second statement is always a GOSUB 1080.

The subroutine at line 1080 checks to see if the operating frequency (*OP*) that resulted from the calculation in the first statement falls within the desired band. If it does, the radio name and operating frequency are printed. In any case, *C* is incremented so it points to the information about the next radio. If more radios have been added, then the crystal formulas, each followed by a GOSUB 1080, must be added following line 1030. Each formula should be written using the variable *OP* as the result and *X* as the crystal frequency. For example, if a transmitter operates on 32 times the frequency of its crystal, the formula would be written:

$$OP = 32 * X$$

Finally, if no radio is found that could use the crystal (indicated by *FD* never getting set to 1) the message "SORRY!" is printed and control is transferred back to the prompt message.

By Phil Hughes, WA6SWR, Specialized Systems Consultants, P. O. Box 2847, Olympia, Washington 98507

*Southwest Technical Products.

listing 1. Sample run of XLOC program. Enter the crystal frequency in MHz. The output shows if the crystal is in the specified band for the radio of interest.

```

RUN
Crystal Use Locator

Enter crystal frequency in MHz (or 0 if done)? 11.67267
SDRRY!

Enter crystal frequency in MHz (or 0 if done)? 11.10417
11.10417
GE 7668326-G1 RCVR
447.75012 MHz

Enter crystal frequency in MHz (or 0 if done)? 10.93333
10.93333
GE 7668326-G1 RCVR
441.59988 MHz

Enter crystal frequency in MHz (or 0 if done)? 11.845
11.845
RCA CMU-15 RCVR
441.565 MHz

Enter crystal frequency in MHz (or 0 if done)? 12.3194
12.3194
SWAN FM-2X XMTR
147.8328 MHz
WILSON 1402-SM XMTR
147.8328 MHz
RCA CMU-10 XMTR
443.4984 MHz
GE 7669061-G1 XMTR
443.4984 MHz

Enter crystal frequency in MHz (or 0 if done)? 37.2
37.2
GE 2 MTR RCVR
155.835 MHz

Enter crystal frequency in MHz (or 0 if done)? 0

READY

```

listing 2. XLOC program listing. Seven bands are set up. To add a new band add statements after line 100 to set up new values in the BS and BE arrays. Program will handle 20 Amateur bands; if more are desired, line 30 must be changed.

```

READY
LIST
10 REM XLOC - Crystal Use Locator SSC 1-80
20 REM Band start and end values
30 DIM BS(20),BE(20)
40 BS(1)=28:BE(1)=30
50 BS(2)=50:BE(2)=54
60 BS(3)=28:BE(3)=54
70 BS(4)=144:BE(4)=148
80 BS(5)=144:BE(5)=174
90 BS(6)=438:BE(6)=450
100 BS(7)=420:BE(7)=470
140 REM N# is the radio description
170 REM B is the desired band
180 DIM N$(20),B(20)
190 N$(1)="SWAN FM-2X RCVR"
200 B(1)=4

```

```

210 N$(2)="SWAN FM-2X XMTR"
220 B(2)=4
230 N$(3)="WILSON 1402-SM RCVR"
240 B(3)=4
250 N$(4)="WILSON 1402-SM XMTR"
260 B(4)=4
270 N$(5)="RCA CMU-10 RCVR"
280 B(5)=7
290 N$(6)="RCA CMU-10 XMTR"
300 B(6)=6
310 N$(7)="RCA CMU-15 RCVR"
320 B(7)=6
330 N$(8)="RCA CMU-15 XMTR"
340 B(7)=6
350 N$(9)="LINK 2240 XMTR"
360 B(9)=4
370 N$(10)="LINK 1905 RCVR"
380 B(10)=5
390 N$(11)="LINK 2210 RCVR"
400 B(11)=5
410 N$(12)="GE 7668326-G1 RCVR"
420 B(12)=6
430 N$(13)="GE 7669061-G1 XMTR"
440 B(13)=6
450 N$(14)="GE 2 MTR RCVR"
460 B(14)=5
470 N$(15)="GE 2 MTR XMTR"
480 B(15)=4
490 N$(16)="GE ET-6-B XMTR"
500 B(16)=2
510 N$(17)="GE ER-6-B RCVR"
520 B(17)=2
630 PRINT "Crystal Use Locator"
640 FKINT
650 PRINT "Enter crystal frequency in MHz (or 0 if done)";
660 INPUT X
670 IF X=0 THEN 1200
680 FD=0
690 C=1
700 OP=(X*3)+10.7
710 GOSUB 1080
720 OP=X*12
730 GOSUB 1080
740 OP=(X*9)+10.7
750 GOSUB 1080
760 OP=X*12
770 GOSUB 1080
780 OP=(X*48)+39.1
790 GOSUB 1080
800 OP=X*36
810 GOSUB 1080
820 OP=(X*36)+15.145
830 GOSUB 1080
840 OP=X*36
850 GOSUB 1080
860 OP=X*48
870 GOSUB 1080
880 OP=(X*18)-5
890 GOSUB 1080
900 OP=(X*4)-4.943
910 GOSUB 1080
920 OP=(X*36)+48
930 GOSUB 1080
940 OP=X*36
950 GOSUB 1080
960 OP=(X*4)+7.035
970 GOSUB 1080
980 OP=X*24
990 GOSUB 1080
1000 OP=X*24
1010 GOSUB 1080
1020 OP=X*16
1030 GOSUB 1080
1040 IF FD=0 THEN PRINT "SDRRY!"
1050 PRINT
1060 PRINT
1070 GOTO 650
1080 REM Check for match
1090 IF OP>BE(B(C)) THEN 1180
1100 IF OP<BS(B(C)) THEN 1180
1110 IF FD=1 THEN 1160
1120 FD=1
1130 PRINT
1140 PRINT TAB(5);X
1150 PRINT
1160 PRINT N$(C)
1170 PRINT TAB(5);OP;"MHz"
1180 C=C+1
1190 RETURN
1200 END

```

READY

transmission-line circuit design

Using distributed
resonant circuits
for VHF/UHF
transmission lines —
equations and design
relationships

dedication statement

I would like to dedicate this article to the memory of Jim Fisk, WIHR, since it was due to his encouragement that this extensive task was undertaken.

Resonant transmission-line circuits predominate at frequencies above 50 MHz. The reason is that finite practical lengths of transmission line can be readily used to achieve resonance rather than lumped values of capacitance and inductance in the less-than-10 pF and low-nH range respectively. This article shows how various transmission-line configurations can be designed into resonant circuits at these higher frequencies.

The spectrum above 50 MHz becomes ever more important as advances in technology permit more extensive exploitation. Low-noise-figure devices, higher-power devices, greater efficiency, and low cost have yielded hardware today that ten years ago was considered impossible.

Technology advances haven't been limited to devices only. The complex calculations required for rf and other engineering problems have been simplified by programmable scientific calculators such as the Hewlett-Packard HP-67/97 and Texas Instruments

By H. M. Meyer, Jr. W6GGV, 29330 Whitley Collins Drive, Rancho Palos Verdes, California 90274

TI-59. These tools permit solution of design problems in hours rather than weeks, with a precision previously considered unrealistic. An interesting by-product of the time saved is that a more thorough trade-off between design parameters can be achieved, yielding a more efficient final design. More than 15 years ago I addressed this same topic (reference 1), necessarily more crudely. This article provides a fresh approach, using more elegant tools, which results in significantly expanded and new data.

The article is divided into three parts. First I address the governing expressions for calculating resonant transmission-line parameters. Included are data on design relationships such as efficiency, coupling, and resonating capacitance. The second part concerns the geometry of twelve different transmission lines in common use and derives the parameters for resonant-circuit design. The third part gives design examples demonstrating the use of the data provided.

This article is the result of my interest in resonant transmission-line phenomena for over 30 years. Comments, corrections, new formulations, or additional data are welcomed.

calculation of resonant circuits

A description of methods to calculate parameters of resonant transmission-line circuits is provided. After deciding on the physical parameters that fit the chosen configuration, efficiency and coupling are discussed. Graphs and tables are provided.

HP-67/97 programs are detailed using the HP-97 printer capability. Therefore, the tables describing the programs are displayed in HP-97 format. To convert the programs for HP-67 use, refer to the *HP-67 Owners Handbook*, Appendix E, page 324. The programs contained here are usable on the new HP-41C with the same magnetic cards.

Distributed resonant circuits. Distributed resonant circuits are different from lumped-constant circuits: fixed elements of inductance and capacitance are not required for resonance. Instead, the uniform values of distributed inductance and capacitance per unit length of transmission line are used together with a fixed line length and a capacitance, with the physical configuration determining line impedance, Z_0 .

Distributed resonant circuits become practical at frequencies of 50 MHz and above because reasonable values of loaded circuit Q can be achieved with realistic geometries. Furthermore, since there are many transmission-line configurations to choose from, space constraints are readily met.

Optimum transmission-line configurations are generally available. Each is chosen to fit within the physi-

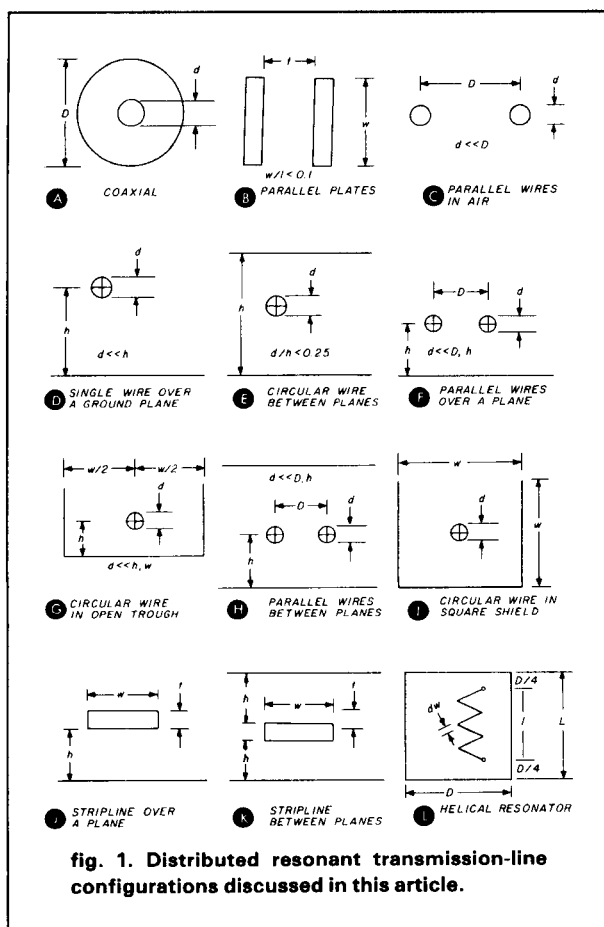

fig. 1. Distributed resonant transmission-line configurations discussed in this article.

cal dimensions, materials, and hardware available. To provide maximum flexibility, twelve different configurations are discussed. See fig. 1.

To determine the parameters of a resonant quarter-wavelength ($\lambda/4$) segment of transmission line, the following expression is used:

$$X_C = Z_0 \tan \beta \ell \quad (1)$$

$$\text{where } X_C = \frac{1}{2\pi FC}; \text{ capacitive reactance} \quad (2)$$

necessary to resonate line section

F = resonant frequency (hertz)

C = capacitance at the unterminated end of the $\lambda/4$ line (farads)

β = electrical degrees per unit length at the resonant frequency ($^\circ/\text{in.}$ or $^\circ/\text{cm}$)

Z_0 = transmission-line impedance (ohms)

ℓ = length of line used (inches or cm)

A coaxial line cross section is shown in fig. 2A, which illustrates the key parameters considered. The ratio of D/d determines line impedance Z_0 . (This parameter is discussed in detail in a following sec-

table 1. HP-67/97 program for calculating Z_0 , C , β , or F given any three unknowns.

step	HP-97 key	HP-97 code	step	HP-97 key	HP-97 code	step	HP-97 key	HP-97 code
001	*LBLA	21 11	051	RCL7	36 07	103	CHS	- 22
002	STO0	35 00	052	X = 0?	16-43	104	÷	- 24
003	3	03	053	RTN	24	105	STO4	35 04
004	0	00	054	x	- 35	106	RTN	24
005	0	00	055	Pi	16-24	107	*LBL4	21 04
006	X=Y	- 41	056	2	02	108	2	02
007	÷	- 24	057	x	- 35	109	4	04
008	.	- 62	058	x	- 35	110	0	00
009	0	00	059	1/X	52	111	STO9	35 09
010	2	02	060	STO6	35 06	112	*LBL6	21 06
011	5	05	061	RTN	24	113	2	02
012	4	04	062	*LBL1	21 01	114	ST-9	35-45 09
013	÷	- 24	063	RCL5	36 05	115	RCL3	36 03
014	STO1	35 01	064	RCL2	36 02	116	RCL4	36 04
015	PSE	16 51	065	x	- 35	117	x	- 35
016	3	03	066	TAN	43	118	1-X	52
017	6	06	067	1/X	52	119	1	01
018	0	00	068	RCL6	36 06	120	3	03
019	X=Y	- 41	069	x	- 35	121	.	- 62
020	÷	- 24	070	STO3	35 03	122	4	04
021	STO2	35 02	071	P/S	51	123	7	07
022	PSE	16 51	072	*LBL2	21 02	124	5	05
023	RCL0	36 00	073	RCL6	36 06	125	x	- 35
024	EEX	- 23	074	RCL3	36 03	126	RCL9	36 09
025	6	06	075	÷	- 24	127	x	- 35
026	x	- 35	076	TAN -1	16 43	128	STOB	35 12
027	STO7	35 07	077	RCL2	36 02	129	RCL5	36 05
028	RTN	24	078	÷	- 24	130	3	03
029	*LBLB	21 12	079	STO5	35 05	131	6	06
030	STO3	35 03	080	R/S	51	132	0	00
031	RTN	24	081	*LBL3	21 03	133	x	- 35
032	*LBLC	21 13	082	RCL2	36 02	134	RCL9	36 09
033	STO4	35 04	083	RCL5	36 05	135	÷	- 24
034	GSB9	23 09	084	x	- 35	136	TAN	43
035	RTN	24	085	TAN	43	137	RCLB	36 12
036	*LBLD	21 14	086	RCL3	36 03	138	X=Y	- 41
037	STO5	35 05	087	x	- 35	139	-	- 45
038	RTN	24	088	STO6	35 06	140	.	- 62
039	*LBLa	21 16 11	089	GSB8	23 08	141	0	00
040	STOI	35 46	090	R/S	51	142	1	01
041	DSP5	- 63 05	091	*LBL8	21 08	143	X ≤ Y?	16-35
042	GSBi	23 45	092	RCL7	36 07	144	GTO6	22 06
043	*LBL9	21 03	093	x	- 35	145	RCL9	36 09
044	RCL4	36 04	094	Pi	16-24	146	1	01
045	EEX	- 23	095	2	02	147	1	01
046	1	01	096	x	- 35	148	8	08
047	2	02	097	x	- 35	149	1	01
048	CHS	- 22	098	1/X	52	150	1	01
049	x	- 35	099	STO8	35 08	151	X=Y	- 41
050	STO8	35 08	100	EEX	- 23	152	÷	- 24
			101	1	01	153	STO0	35 00
			102	2	02	154	R/S	51

table 2. HP-67/97 program run time for three frequencies.

F	77.70395 MHz	144.03659 MHz	2952.75 MHz
ℓ	17	13.14	0.4
C	35	10	1.2
Z_0	70	70	70
run time	2 min. 10 sec.	3 min. 54 sec.	5 min. 45 sec.

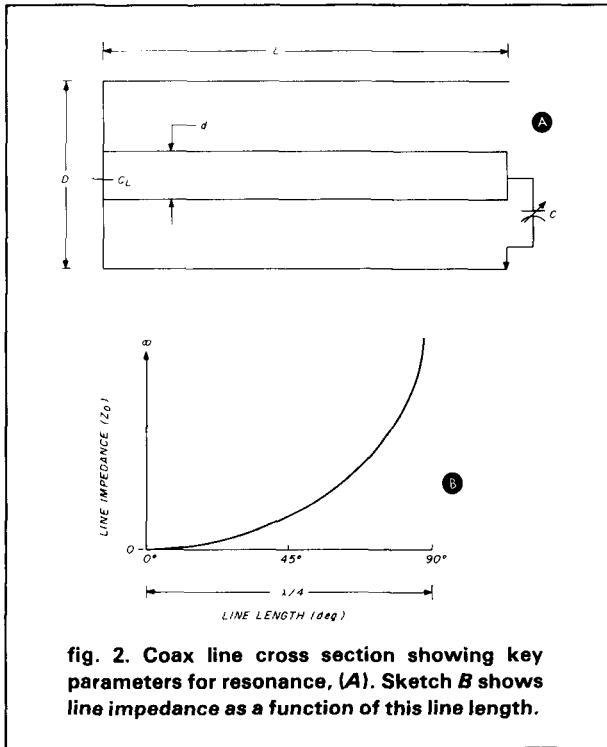

fig. 2. Coax line cross section showing key parameters for resonance, (A). Sketch B shows line impedance as a function of this line length.

tion.) Parameter β (eq. 1) is determined from the following relationship:

$$\beta = \frac{360^\circ}{\lambda} \quad (3)$$

where λ = wavelength in the same units as line length.

The basic relationship is

$$\lambda = \frac{3 \times 10^8}{F_{\text{Hz}}} \quad (4)$$

for $\lambda_{in} = \frac{11,810 \text{ (air)*}}{F_{\text{MHz}}} \quad (5)$

$\lambda_{cm} = \frac{29,999 \text{ (air)*}}{F_{\text{MHz}}} \quad (6)$

*dielectric constant of air = 1.0006

Also the general relationship of line impedance versus electrical degrees for a quarter-wave section, shorted at one end, is shown in fig. 2B. Note that this line impedance is totally different from the capacitive load reactance, X_C , in eq. 1, which resonates the line length.

Computer program. An HP-67/97 program was

written to calculate Z_0 , C, ℓ , and F, given any three parameters. The program is shown in table 1. Since the solution of eq. 2 for F yields a transcendental function, an approximation convergence solution is used when frequency is requested. The lower limit of this program is 49.21 MHz, where $\lambda = 240$ inches, and the program requires a match to 1 per cent to achieve a solution. If lower frequency requirements

table 3. Register contents for HP-67/97 program when calculating Z_0 , C, ℓ , and F.

STO 0	F_{MHz}
STO 1	λ_{inches}
STO 2	$\beta_{\circ/\text{inch}}$
STO 3	Z_0
STO 4	C_{pF}
STO 5	ℓ_{inches}
STO 6	$X_{C \text{ ohms}}$
STO 7	F_{Hz}
STO 8	C_{farads}
{ STO 9 }	transient for loop
{ STO B }	

are necessary, the values in the program may be changed in steps 108, 109, and 110 (table 1). The maximum wavelength-to-lowest-frequency ratio is 999 inches or 11.82 MHz (eq. 5).

The lower frequency of 49.21 MHz was chosen in this program to minimize the solution time. The higher the frequency away from the beginning trial frequency of 49 MHz, the longer the computing time — minutes are involved. (See table 2.)

Table 3 identifies the register contents used in the HP-67/97 program. Table 4 identifies the formulas used for calculation. Table 5 shows how the program is controlled for each desired value. Table 6 shows sample problems entered and the calculated results.

table 4. HP-67/97 formulas for calculating Z_0 , ℓ , C, and F.

calculates Z_0

$$Z_0 = \frac{\tan \beta \ell}{X_C} \quad (7)$$

calculates ℓ_{inches}

$$\frac{\tan^{-1} \beta \ell}{\beta} = \frac{X_C}{Z_0} \quad (8)$$

calculates C_{farads} for resonance

$$C = \frac{I}{2 F \pi Z_0 \tan \beta \ell} \quad (9)$$

calculates F_{MHz}^*

$$\frac{13.475 \lambda_{in}}{C_{\text{pF}}} = Z_0 \tan \frac{360^\circ}{\lambda_{in}} \ell \quad (10)$$

note: $\tan^{-1} = \text{arctan}$.

*iteratively solved for a value of λ by trial substitution to an accuracy of 0.01.

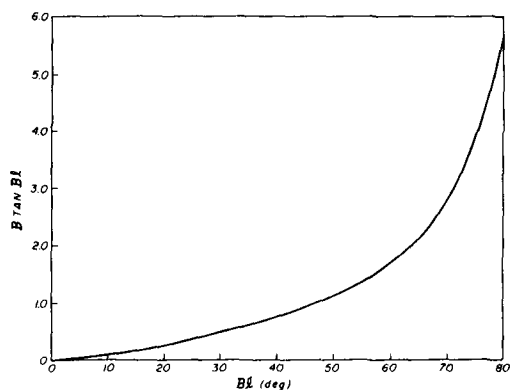

fig. 3. Plot of tangent βl (degrees) for calculating X_C or Z_0 .

Each of four separate calculations is shown with the repeatability for the same values indicated. Note that when F_{MHz} is requested a small error results of about 4 out of 14,440 in frequency (0.03 per cent). This small error results from the convergence solu-

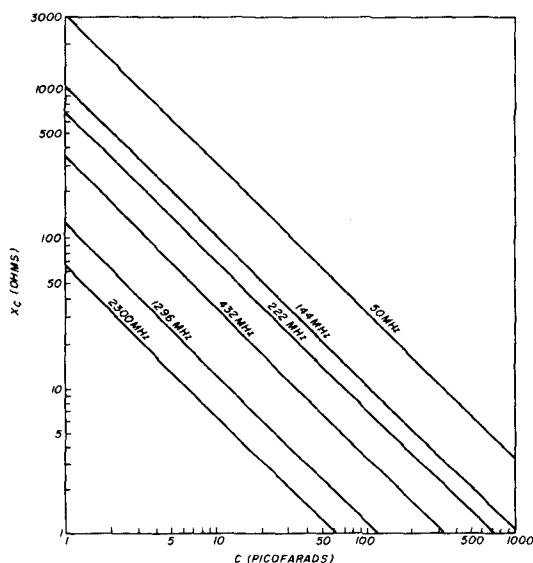

fig. 4. Plot of X_C versus C for the vhf/uhf bands.

table 5. HP-67/97 program control for calculating Z_0 , C , l , and F .

enter F_{MHz}	press A	(MHz)
enter Z_0	press B	(ohms)
enter C_{pF}	press C	(pF)
enter l	press D	(inches or cm)

Enter any three of the above and calculate the fourth by selecting

- 1 Z_0
- 2 l
- 3 C_{pF}
- 4 F_{MHz}

and press fa

table 6. Sample problems and results.

	1	2	3	4
F_{MHz}	144	144	144	144.03659*†
Z_0	70	70*	70	70
C_{pF}	10	10	10*	10
l inches	13.13522*	13.13522	13.13522	13.13622

*calculated value
†loop run time 3 min. 54 sec.

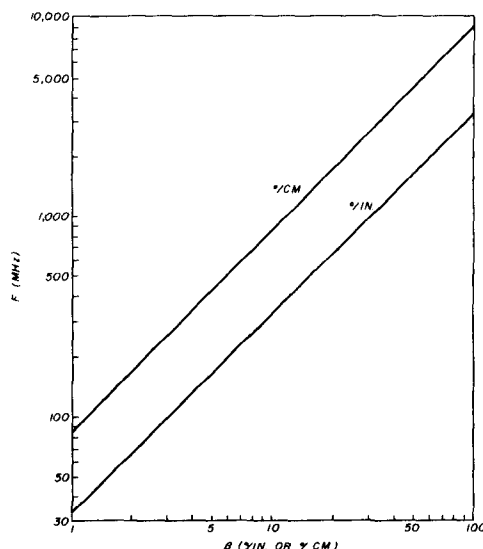

fig. 5. Frequency as a function of β in degrees per inch or degrees per cm.

tion discussed previously but is well within acceptable design limits.

Fig. 3 is a plot of the tangent βl versus degrees for calculating X_C or Z_0 manually. Fig. 4 shows X_C in ohms versus C in picofarads for each of the vhf/uhf Amateur bands. Fig. 5 shows β in degrees per inch and degrees per cm versus frequency.

Considerations and useful relationships. An important consideration in resonant circuits is efficiency, which is determined from

$$\text{efficiency per cent} = \frac{\text{unloaded } Q - \text{loaded } Q}{\text{unloaded } Q} \times 100 \quad (11)$$

Thus the highest possible unloaded Q is desirable to achieve the best tank-circuit efficiency. Q is generally greater for fully enclosed and shielded transmission-line configurations. Unshielded lines have a low unloaded Q because of radiation losses. Also low values of Z_0 cause less radiation, so a low value of Z_0 should be chosen for unshielded lines. For coaxial geometries the highest values of unloaded Q are realized with Z_0 between 70-85 ohms.

The parameter Q can be estimated by dividing the center resonant frequency of the circuit under consideration by its 3-dB bandwidth (single-section filters or loosely coupled sections). For stripline configurations with dielectric loading, line efficiency is dominated by dielectric constraints (discussed in detail in references 2 and 3).

In most cases it's important to make the transmission lines electrically as long as possible within the $n \lambda/4$ constraints. This means that the value of capacitance needed to tune the circuit to resonance should be as small as practicable. This value must include the variability of the active/passive device or devices used. If a desired range of frequency is to be tuned, calculate the required capacitance at the higher frequency then multiply by the square of the frequency ratio; that is:

$$C_{F_{high}} \left(\frac{F_{high}}{F_{low}} \right)^2 = \text{ratio} \quad (12)$$

This equation yields the required capacitance range exclusive of device capacitance. If passive and active devices are used, their minimum capacitances should be subtracted from the value calculated to cover the desired bandwidth with a minimum of capacitance. Nominally values of tuning capacitance for input and output circuits should be designed for ± 25 per cent capacitance tuning range from the center design value. For example, if a single 4CX250B coaxial tank circuit is to tune between 144 MHz-148 MHz with a Z_0 of 77 ohms and a cavity length of 10 inches, what

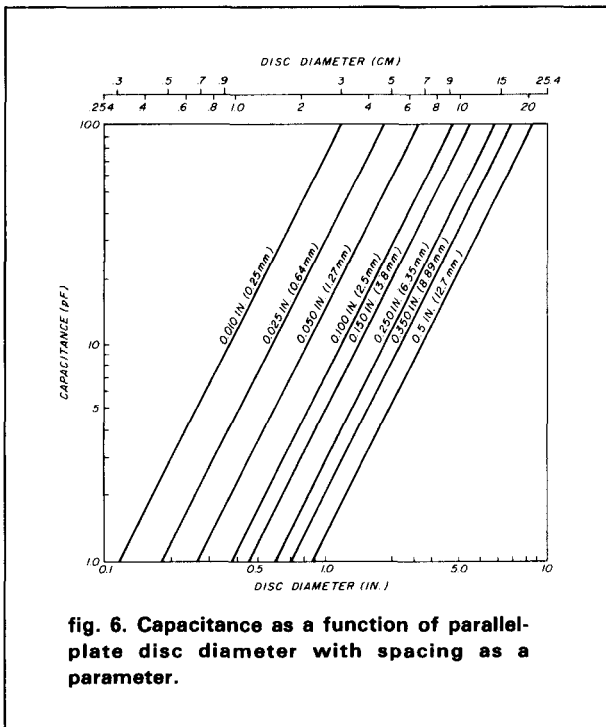

fig. 6. Capacitance as a function of parallel-plate disc diameter with spacing as a parameter.

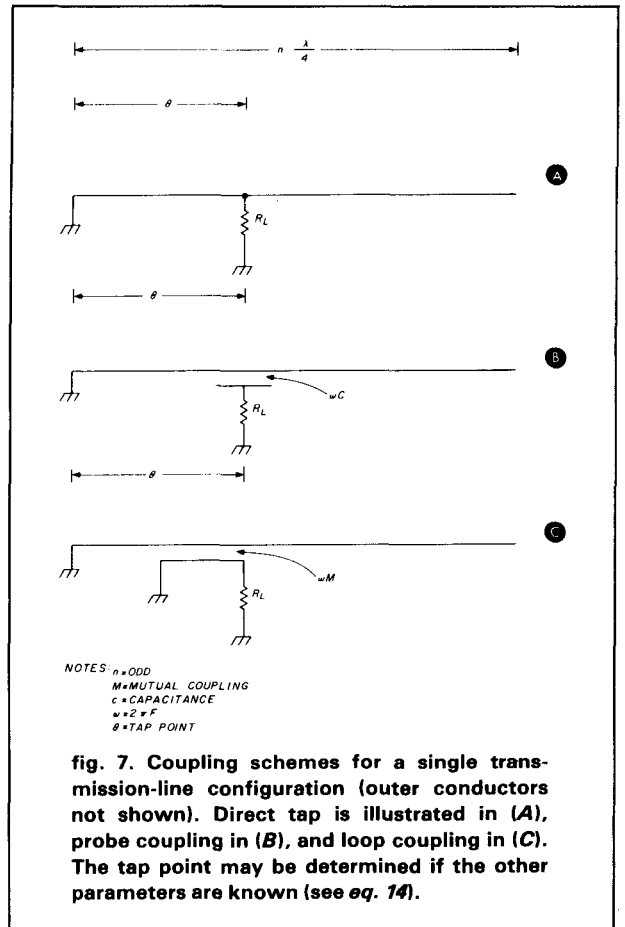

fig. 7. Coupling schemes for a single transmission-line configuration (outer conductors not shown). Direct tap is illustrated in (A), probe coupling in (B), and loop coupling in (C). The tap point may be determined if the other parameters are known (see eq. 14).

is the capacitance tuning range if the minimum tube-output capacitance is 4.0 pF? From eq. 1, the capacitance required is 13.9 pF at 148 MHz. The frequency ratio is:

$$\frac{(148)^2}{(144)^2} = 1.06$$

When multiplied by the resonating capacitance, 13.9 pF yields 14.7 pF. Subtracting the minimum tube capacitance of 4.00 pF yields 10.7 pF as the minimum tuning capacitance required for the design conditions given. The ± 25 -per cent rule previously suggested provides a more conservative realization (13.5 pF ± 25 per cent).

Tuning capacitor. Construction of the tuning capacitor can be simplified by using parallel plate discs. Fig. 6 shows capacitance versus diameter for parallel-plate capacitors with various spacings between discs. In some cases a dielectric can be used, so the capacitance value is then multiplied by the dielectric constant. The basic equation is:

$$C_{pF} = 0.225 \epsilon_r \left[(N-1) \frac{A}{T} \right] \quad (13)$$

where ϵ_r = dielectric constant
 N = number of plates
 A = area (square inches)
 T = spacing (inches)

(For metric dimensions, substitute 0.0885 for 0.225.)

It's important to note that an appropriate spacing between discs must be chosen based on the voltage involved. Very close spacings should be avoided, even under low-voltage conditions, unless excellent parallelism can be achieved. Under high-voltage conditions (greater than 1000 Vdc), no sharp edges are permitted. All edges must be rounded and smooth to prevent build-up of high electrical fields, which can cause flashover.

Coupling into and out of transmission-line circuits can be made using a direct tap, probe coupling, or loop coupling. This idea is shown in **fig. 7** for a single transmission line configuration with the outer conductors not shown. Other techniques are possible but are not discussed.

At resonance θ , the tap point, may be determined if the other parameters are known. In **fig. 7A**, the equation is:

$$R = \frac{Z_0^2}{R_L} \sin^2 \theta \quad (14)$$

where R = resistance at resonance at θ on the line (ohms).

Z_0 = transmission-line impedance (ohms).

θ = electrical degrees from ground.

R_L = load resistance (ohms).

If θ is desired with the other values known,

$$\theta = \sin^{-1} \sqrt{\frac{RR_L}{Z_0^2}} \quad (15)$$

In **fig. 7B** the equation is:

$$R = Z_0^2 \omega C^2 R_L \sin^2 \theta, \quad (16)$$

which can be solved for C :

$$C_{\text{farads}} = \sqrt{\frac{R}{Z_0^2 \omega^2 R_L \sin^2 \theta}} \quad (17)$$

The loop-coupled case (**Fig. 7C**) is described by:

$$R = \frac{\omega^2 M^2}{R_L} \cos^2 \theta \quad (18)$$

where M = mutual coupling.

Parameter R is normally equal to R_L when coupling to external transmission lines. A reasonable value for mutual coupling, M , is between 0.5 and 0.8, depending on how tightly the loop is coupled to the line. For the loop, X_L should be tuned out with a variable capacitor in series with the loop to ground if X_L is greater than $R_L/100$. The amount of capacitance required may be calculated from the values of inductance

as a function of conductor size given in **table 7**. These values are for straight lengths of conductor but are useful in determining design values for loops. Note that, for equal lengths of conductor with current flowing in opposite directions, the effective inductance is cancelled.

It's clear from **table 7** that the law of diminishing returns prevails when larger-diameter conductors are substituted for smaller sizes to decrease inductance. The inductance is halved from No. 22 to 3/16-inch tubing. The only reason for using a larger loop conductor size is for current-handling capability (2 kW PEP output at 144 MHz requires 3/16-inch copper tubing).

table 7. Conductor size versus straight pigtail sheet inductance.

conductor	inductance	
	nH/in.	(nH/cm)
1/4 in. tubing	9.005	(3.55)
3/16 in. tubing	10.446	(4.12)
1/8 in. tubing	12.526	(4.93)
AWG 8 wire	12.374	(4.87)
AWG 10 wire	13.564	(5.34)
AWG 12 wire	14.742	(5.70)
AWG 14 wire	15.92	(6.27)
AWG 16 wire	16.89	(6.65)
AWG 18 wire	18.091	(7.12)
AWG 20 wire	19.23	(7.57)
AWG 22 wire	20.387	(8.03)
AWG 24 wire	21.516	(8.47)
AWG 26 wire	22.691	(8.93)
AWG 28 wire	23.832	(9.38)

A further use of **table 7** is to calculate lumped resonant circuits at vhf/uhf from the length of conductor and a resonating capacitor. It's reasonably accurate and useful if stray capacitances are considered.

references

1. H.M. Meyer, Jr., W6GGV, "The Design of VHF Tank Circuits," 73, November, 1964.
2. H.A. Wheeler, "Transmission Line Properties of a Stripline Between Parallel Planes," *IEEE Professional Group on Microwave Theory and Techniques*, Volume MIT 26 No. 11, November, 1978, pages 866-876.
3. H.A. Wheeler, "Transmission Line Properties of a Strip on a Dielectric Sheet on a Plane," *IEEE Transactions on Microwave Theory and Techniques*, Volume MIT 25, August, 1977, pages 631-647.

bibliography

- Bahl, Dr. I.J., "Use Exact Methods for Microstrip Design," *Microwaves*, December, 1978, pages 61-62.
- Gardiol, F.E., "HP-65 Program Computes Microstrip Impedance," *Microwaves*, December, 1977, pages 186-187.
- Murdock, B.K., *Handbook of Electronics Design and Analysis Procedures Using Programmable Calculators*, Van Nostrand Reinhold, 1979.

ham radio

The Question we seem to get most often from our customers:

"WHEN IS ICOM COMING OUT WITH A HAND~HELD?"

ICOM IC-2A SYNTHESIZED 2 METER HAND HELD

FEATURES YOU'VE WANTED

- 800 T/R Channels. Synthesized.
- 1.5 Watt Output High/Low Power Battery Saving Switch to .15 Watt.
- Separate built in Speaker & Mic. Excellent audio quality.
- Compact. About the size of a dollar bill.
- Variable size Nicad Power Pack, 3 sizes available to suit your needs. (250 MA standard). Makes the IC-2A the most compact on the market.
- ICOM level Receiver Performance-ICOM Quality Receiver in a compact package (.2uv/20db typical)
- Optional Tone Pad, Desk Charger, Speaker/Mic available.
- With slip on/slip off Bottom Nicad Pack, you can vary the size from about 116 mm high to 175 mm high. Easy to carry extra Snap-on packs with you for extended trips.

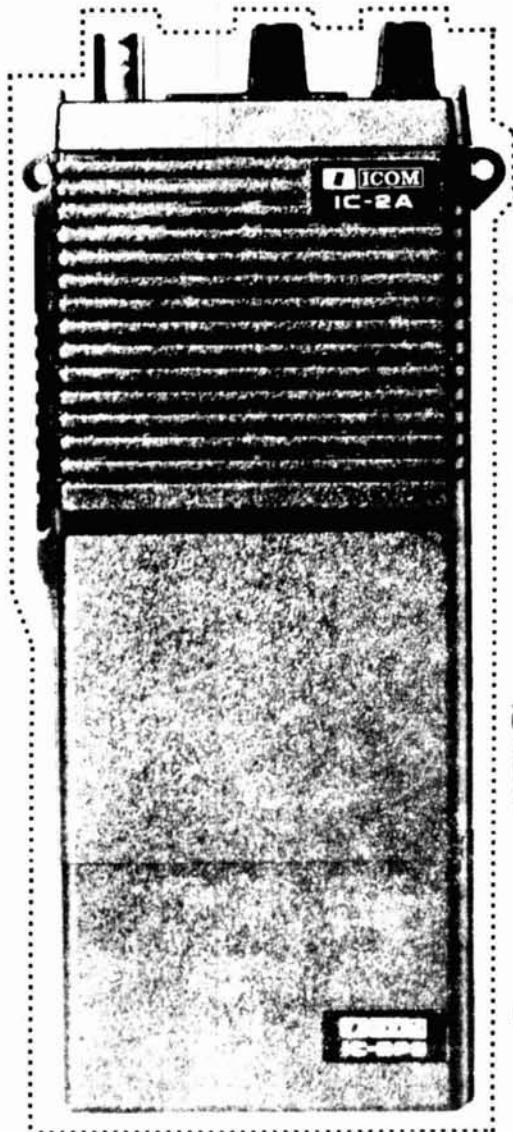

BACK VIEW

±600 khz offset
simplex/duplex
Hi/lo power



TOP VIEW

BNC antenna connector
"Rubber Duckie" standard
transmit indicator
squelch
volume control
on/off
5 khz channel selection
10 khz channel selection
speaker/mic jack

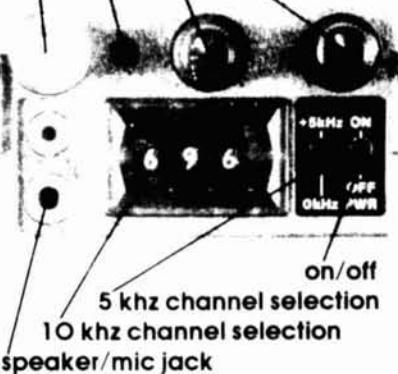

THE ANSWER IS: NOW!

All 800 channels of it!

PHONE: (312) 848-6777



SPECTRONICS, INC. — 1009 GARFIELD ST., OAK PARK, ILL.-60304

the weekender

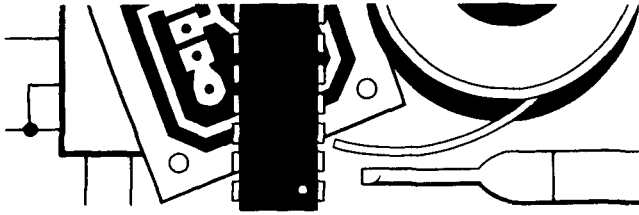

simple CW memory

The memory (fig. 1) uses standard TTL ICs and a 2102 1k x 1 bit RAM. Information written into the memory can be read out at a faster or slower rate by merely changing the clock rate. A built-in sidetone generator allows monitoring while writing into memory as well as during readout or when keying the transmitter directly. A relay is used to key the transmitter.

Approximately six seconds of recording time occurs at the fastest clock rate, and about 45 seconds occurs at the slowest rate. Some distortion may occur, however, at the slowest setting. Mid setting

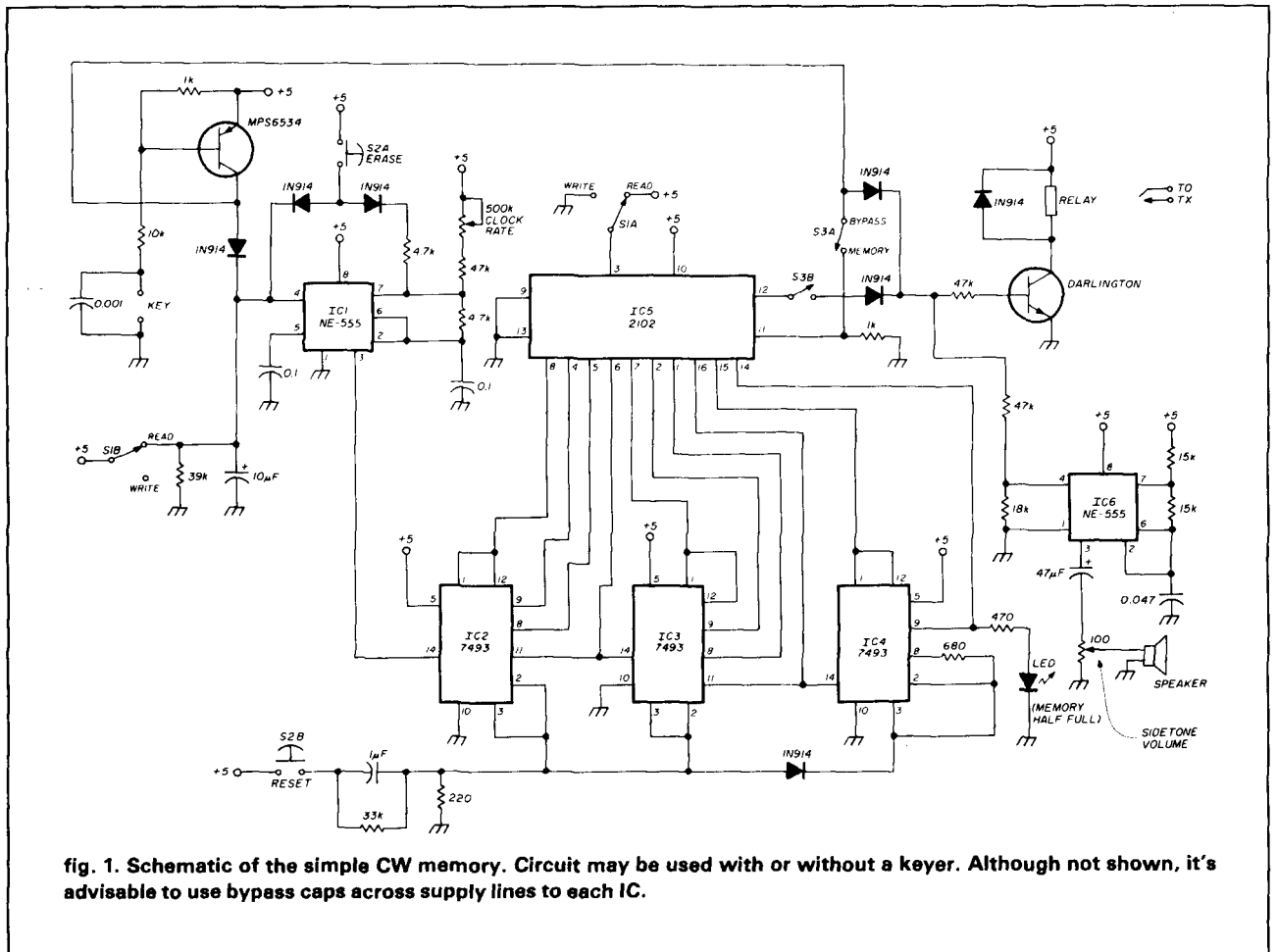

fig. 1. Schematic of the simple CW memory. Circuit may be used with or without a keyer. Although not shown, it's advisable to use bypass caps across supply lines to each IC.

At the risk of overdoing it, I'd like to submit my version of the simple CW memory. I can't lay claim to the design and admit all I did was combine parts that intrigued me the most from several articles.^{1,2,3} The circuit can be used with or without a keyer and can be built in a couple of evenings.

By Ray Megirian, K4DHC, 606 SE 6 Avenue, Deerfield Beach, Florida 33441

gives about 30 seconds and should be adequate for most CQs or ID signals.

Oscillator. IC1, an NE-555 timer, is used for the clock oscillator and, in turn, drives the three 7493 4-bit binary counters. These, in turn, provide the 10-bit address codes to the RAM. IC4 is connected to reset at the count of 3 since the C and D outputs are not needed.

Input power. Power is applied to the clock oscillator only during key-down periods. During this time a

FALL FAVORITES

charge is accumulated in the 10 μ f capacitor connected to IC1 pin 4. When the key is up, this charge keeps the oscillator running long enough to fill in the normal keying spaces. If you pause or stop momentarily, however, the oscillator shuts down and RAM storage capacity is not wasted.

RAM output. The output data from the RAM drives a transistor that operates the keying relay. The same signal also actuates the sidetone oscillator, another NE-555 timer. An LED indicator shows when the memory is half full. At that point the LED lights and stays lit until the count returns to zero.

Memory. When the unit is first turned on, the memory will store random data and must be cleared. To clear the memory at this time, or when a message is to be rewritten, the **READ/WRITE** switch is set to **WRITE** and the **RESET/ERASE** switch flipped to **ERASE**. The switch should be held long enough for a complete cycle as shown by the LED. The **ERASE** switch turns on the clock oscillator and also shunts the normal timing resistor with one of much lower value. This action boosts the frequency to a rate that cycles the system rapidly, and the RAM can be cleared in a couple of seconds.

recording a message

Set the **CLOCK RATE** control for the time needed. Switch the **MEMORY/BYPASS** switch to **MEMORY** and **READ/WRITE** switch to **WRITE**. Press the **RESET** switch momentarily to return the system to zero. Key in the message. Switch to **READ** and press **RESET**. The message should play back immediately. Message speed may be adjusted by resetting the clock rate. The message will repeat until interrupted. If it's desired to key the transmitter directly, the memory can be bypassed with the **MEMORY/BYPASS** switch, which won't disturb data in storage.

hardware

Laying out a PC board for a one-time project such as this was not considered worth the effort. The parts were assembled and wired on a piece perforated board. The keying relay I used was a reed type with 5-volt coil. Also, the **RESET/ERASE** functions were combined in a spdt momentary toggle switch with center OFF. I used a small sloping panel cabinet to house the device. Although not shown in **fig. 1**, it's advisable to sprinkle some bypass capacitors across supply lines to each IC.

references

1. S. H. Phillips, G4EYR, "A Simple Multi-Purpose Memory," *Radio Communication*, July, 1979.
2. S. Price, G4BWE, "G4BWE CW Memory," *Radio Communication*, September, 1979.
3. Eric Unruh, WB0RYN, "Poor Man's CW Memory," 73, June, 1979.

ham radio



NEW!
11CO5 1 GHz, pre. Special \$59.95
ATF 417 pre-amp. net Special \$19.95
MRF 901 UHF transistor, 1 GHz Special \$3.95

COMPLETE KITS: CONSISTING OF EVERY ESSENTIAL PART NEEDED TO MAKE YOUR COUNTER COMPLETE. **HAL-600A** 7-DIGIT COUNTER WITH FREQUENCY RANGE OF ZERO TO 600 MHz. FEATURES TWO INPUTS: ONE FOR LOW FREQUENCY AND ONE FOR HIGH FREQUENCY; AUTOMATIC ZERO SUPPRESSION. TIME BASE IS 1.0 SEC OR .1 SEC GATE WITH OPTIONAL 10 SEC GATE AVAILABLE. ACCURACY \pm .001%. UTILIZES 10-MHz CRYSTAL 5 PPM. **COMPLETE KIT \$129**

HAL-300A 7-DIGIT COUNTER (SIMILAR TO 600A) WITH FREQUENCY RANGE OF 0-300 MHz. **COMPLETE KIT \$109**

HAL-50A 8-DIGIT COUNTER WITH FREQUENCY RANGE OF ZERO TO 50 MHz OR BETTER. AUTOMATIC DECIMAL POINT, ZERO SUPPRESSION UPON DEMAND. FEATURES TWO INPUTS: ONE FOR LOW FREQUENCY INPUT, AND ONE ON PANEL FOR USE WITH ANY INTERNALLY MOUNTED HALTRONIX PRE-SCALER FOR WHICH PROVISIONS HAVE ALREADY BEEN MADE. 1.0 SEC AND .1 SEC TIME GATES. ACCURACY \pm .001%. UTILIZES 10-MHz CRYSTAL 5 PPM. **COMPLETE KIT \$109**

FREE: HAL-79 CLOCK KIT PLUS AN INLINE RF PROBE WITH PURCHASE OF ANY FREQUENCY COUNTER.

PRE-SCALER KITS

HAL 300 PRE (Pre-drilled G-10 board and all components) \$14.95

HAL 300 A/PRE (Same as above but with preamp) \$24.95

HAL 600 PRE (Pre-drilled G-10 board and all components) \$29.95

HAL 600 A/PRE (Same as above but with preamp) \$39.95

NEW! **HAL-1 GHz PRESCALER**, VHF & UHF INPUT & OUTPUT, DIVIDES BY 1000. OPERATES ON A SINGLE 5 VOLT SUPPLY. **PREBUILT & TESTED \$79.95**

TOUCH TONE DECODER KIT

HIGHLY STABLE DECODER KIT. COMES WITH 2 SIDED, PLATED THRU AND SOLDER FLOWED G-10 PC BOARD, 7-567's, 2-7402, AND ALL ELECTRONIC COMPONENTS. BOARD MEASURES 3-1/2" x 5-1/2" INCHES. HAS 12 LINES OUT. ONLY \$39.95

DELUXE 12-BUTTON TOUCHTONE ENCODER KIT UTILIZING THE NEW ICM 7206 CHIP. PROVIDES BOTH VISUAL AND AUDIO INDICATIONS! COMES WITH ITS OWN TWO-TONE ANODIZED ALUMINUM CABINET. MEASURES ONLY 2-3/4" x 3-3/4". COMPLETE WITH TOUCH-TONE PAD, BOARD, CRYSTAL, CHIP AND ALL NECESSARY COMPONENTS TO FINISH THE KIT. **PRICED AT \$29.95**

FOR THOSE WHO WISH TO MOUNT THE ENCODER IN A HAND-HELD UNIT, THE PC BOARD MEASURES ONLY 9/16" x 1-3/4". THIS PARTIAL KIT WITH PC BOARD, CRYSTAL, CHIP AND COMPONENTS. **PRICED AT \$14.95**

ACCUKEYER (KIT) THIS ACCUKEYER IS A REVISED VERSION OF THE VERY POPULAR WB4VVF ACCUKEYER ORIGINALLY DESCRIBED BY JAMES GARRETT, IN QST MAGAZINE AND THE 1975 RADIO AMATEUR'S HANDBOOK. **\$16.95**

ACCUKEYER — MEMORY OPTION KIT PROVIDES A SIMPLE, LOW COST METHOD OF ADDING MEMORY CAPABILITY TO THE WB4VVF ACCUKEYER. WHILE DESIGNED FOR DIRECT ATTACHMENT TO THE ABOVE ACCUKEYER, IT CAN ALSO BE ATTACHED TO ANY STANDARD ACCUKEYER BOARD WITH LITTLE DIFFICULTY. **\$16.95**

PRE-AMPLIFIER

HAL-PA-19 WIDE BAND PRE-AMPLIFIER, 2-200 MHz BANDWIDTH (-3dB POINTS), 19 dB GAIN. **FULLY ASSEMBLED AND TESTED \$8.95**

NEW! **CLOCK KIT — HAL 79 FOUR-DIGIT SPECIAL — \$7.95.** OPERATES ON 12-VOLT AC (NOT SUPPLIED). PROVISIONS FOR DC AND ALARM OPERATION

6-DIGIT CLOCK • 12/24 HOUR

COMPLETE KIT CONSISTING OF 2 PC G-10 PRE-DRILLED PC BOARDS, 1 CLOCK CHIP, 6 FND COMM. CATH. READOUTS, 13 TRANS., 3 CAPS, 9 RESISTORS, 5 DIODES, 3 PUSH-BUTTON SWITCHES, POWER TRANSFORMER AND INSTRUCTIONS. DON'T BE FOOLED BY PARTIAL KITS WHERE YOU HAVE TO BUY EVERYTHING EXTRA. **PRICED AT \$12.95**

CLOCK CASE AVAILABLE AND WILL FIT ANY ONE OF THE ABOVE CLOCKS. REGULAR PRICE... \$6.50 BUT ONLY \$4.50 WHEN BOUGHT WITH CLOCK.

SIX-DIGIT ALARM CLOCK KIT FOR HOME, CAMPER, RV, OR FIELD-DAY USE. OPERATES ON 12-VOLT AC OR DC, AND HAS ITS OWN 60-Hz TIME BASE ON THE BOARD. COMPLETE WITH ALL ELECTRONIC COMPONENTS AND TWO-PIECE, PRE-DRILLED PC BOARDS. BOARD SIZE 4" x 3". COMPLETE WITH SPEAKER AND SWITCHES. IF OPERATED ON DC, THERE IS NOTHING MORE TO BUY. **PRICED AT \$16.95**

*TWELVE-VOLT AC LINE CORD FOR THOSE WHO WISH TO OPERATE THE CLOCK FROM 110-VOLT AC. **\$2.50**

SHIPPING INFORMATION — ORDERS OVER \$20.00 WILL BE SHIPPED POSTPAID EXCEPT ON ITEMS WHERE ADDITIONAL CHARGES ARE REQUESTED. ON ORDERS LESS THAN \$20.00 PLEASE INCLUDE ADDITIONAL \$1.50 FOR HANDLING AND MAILING CHARGES. SEND SASE FOR FREE FLYER.

DISTRIBUTOR FOR

Aluma Tower • AP Products

(We have the new Hobby-Blox System)



"HAL"
 HAROLD C. NOWLAND
 W8ZXH

HAL-TRONIX

P. O. BOX 1101
 SOUTHGATE, MICH. 48195
 PHONE (313) 285-1782

TS-830S

"Top-notch"... VBT, notch, IF shift, wide dynamic range

The TS-830S has every conceivable operating feature built-in for 160-10 meters (including the three new bands). It combines a high dynamic range with variable bandwidth tuning (VBT), IF shift, and an IF notch filter, as well as very sharp filters in the 455-kHz second IF. Its optional VFO-230 remote digital VFO provides five memories.

TS-830S FEATURES:

- LSB, USB, and CW on 160-10 meters, including the new 10, 18, and 24-MHz bands. Receives WWV.
- Wide receiver dynamic range. Junction FETs in the balanced mixer, MOSFET RF amplifier at low level, and dual resonator for each band.
- Variable bandwidth tuning (VBT). Varies IF filter pass-band width.

- Notch filter (high-Q active circuit in 455-kHz second IF).
- IF shift (passband tuning).
- Built-in digital display (six digits, fluorescent tubes), analog subdial, and display hold (DH) switch.
- Noise-blanker threshold level control.
- 6146B final with RF negative feedback. Runs 220 W PEP (SSB)/180 W DC (CW) input on all bands.
- Built-in RF speech processor.
- Narrow/wide filter selection on CW.
- SSB monitor circuit to check transmitted audio quality.
- RIT (receiver incremental tuning) and XIT (transmitter incremental tuning).

OPTIONAL ACCESSORIES:

- SP-230 external speaker with selectable audio filters.
- VFO-230 external digital VFO with 20-Hz steps, five memories, digital display.
- AT-230 antenna tuner/SWR and power meter/antenna switch; 160-10 meters, including three new bands.
- YG-455C (500-Hz) and YG-455CN (250-Hz) CW filters for 455-kHz IF.
- YK-88C (500-Hz) and YK-88CN (270-Hz) CW filters for 8.83-MHz IF. (VFOs for TS-830S, TS-130 Series, and TS-120S are compatible with all three series of transceivers.)



SP-230

TS-830S

VFO-230

AT-230

TS-130S/V

"Small wonder"... processor, N/W switch, IF shift, DFC option

The compact, all solid-state HF SSB/CW mobile or fixed station TS-130 Series transceiver covers 3.5 to 29.7 MHz, including the three new bands.

TS-130 SERIES FEATURES:

- 80-10 meters, including the new 10, 18, and 24-MHz bands. Receives WWV.

- TS-130S runs 200 W PEP/160 W DC input on 80-15 meters and 160 W PEP/140 W DC input on 12 and 10 meters. TS-130V runs 25 W PEP/20 W DC input on all bands.
- Built-in speech processor.
- Narrow/wide filter selection on both CW (500 Hz or 270 Hz) and SSB (1.8 kHz) with optional filters.

- Automatic selection of side-band mode (LSB on 40 meters and below, and USB on 30 meters and above). SSB REVERSE switch provided.
- Built-in digital display.
- Built-in RF attenuator.
- IF shift (passband tuning).
- Effective noise blanker.

OPTIONAL ACCESSORIES:

- PS-30 base-station power supply.
- YK-88C (500 Hz) and YK-88CN (270 Hz) CW filters.
- YK-88SN (1.8 kHz) narrow SSB filter.
- AT-130 compact antenna tuner (80-10 meters, including three new bands).

- SP-120 external speaker.
- VFO-120 remote VFO.
- MB-100 mobile mounting bracket.
- PS-20 base-station power supply for TS-130V.



Optional DFC-230 Digital Frequency Controller

Frequency control in 20-Hz steps with UP/DOWN microphone (supplied with DFC-230). Four memories and digital display. (Also operates with TS-120 and TS-830S.)



PS-30

SP-120

TS-130S

VFO-120

TR-9000

"New 2-meter direction"... compact rig with FM/SSB/CW, scan, five memories

The TR-9000 combines the convenience of FM with long distance SSB and CW. It is extremely compact... perfect for mobile operation. Matching accessories are available for optimum fixed-station operation.

TR-9000 FEATURES:

- FM, USB, LSB, and CW.
- Only 6-11/16 inches wide, 2-21/32 inches high, 9-7/32 inches deep.

- Two digital VFOs, with selectable tuning steps of 100 Hz, 5 kHz, and 10 kHz.
- Digital frequency display. Five, four, or three digits, depending on selected tuning step.
- Covers 143.9000-148.9999 MHz.
- Band scan... automatic busy stop and free scan.
- SSB/CW search of selectable 9.9-kHz bandwidth segments.

- Five memories... four for simplex or ± 600 kHz repeater offsets and the fifth for a non-standard offset (memorizes transmit and receive frequency independently).
- UP/DOWN microphone (standard) for manual band scan.
- Noise blanker for SSB and CW.
- RIT (receiver incremental tuning) for SSB and CW.
- RF gain control.
- CW sidetone.
- Selectable RF power outputs... 10 W (HI)/1 W (LO).
- Mobile mounting bracket with quick-release levers.
- LED indicators... ON AIR, BUSY, and VFO.

OPTIONAL ACCESSORIES:

- PS-20 fixed-station power supply.
- SP-120 fixed-station external speaker.
- BO-9 System Base... with power switch, SEND/RECEIVE switch (for CW), memory-backup power supply, and headphone jack.



PS-20

TR-9000

BO-9

SP-120



TR-2400

"Hand-shack"... synthesized, big LCD, scan, 10 memories, DTMF (Touch-Tone®)



CONVENIENT TOP CONTROLS

The TR-2400 has the most convenient operating features desired in a 2-meter FM hand-held transceiver.

TR-2400 FEATURES:

- Large LCD digital readout. Readable in direct sunlight (virtually no current drain) and in the dark (lamp switch). Shows receive and transmit frequencies and memory channel. "Arrow" indicators show "ON AIR," "MR" (memory recall), "BATT" (battery status), and "LAMP" switch on.

- Keyboard selection of 144.000-147.995 MHz in 5-kHz increments. No "5-UP" switch needed.
- UP/DOWN manual scan in 5-kHz steps from 143.900 to 148.495 MHz.
- 10 memories. Retained with battery backup. "M0" memory may be used to shift transmitter to any frequency for nonstandard-split repeaters.
- Built-in autopatch DTMF (Touch-Tone®) encoder, using all 16 keyboard buttons.
- Automatic memory scan.
- Repeater or simplex operation. Transmit frequency shifts ± 600 kHz or to "M0" memory frequency.
- Reverse switch. Transposes receive and transmit frequencies.
- Subtone switch (tone encoder not Kenwood-supplied).
- Two lock switches to prevent accidental frequency change and accidental transmission.

- External PTT microphone and earphone connectors.
- Rubberized antenna with BNC connector, NiCd battery pack, AC charger, PTT and mic plugs, handstrap, and earphone included.
- Extended operating time with LCD and overall low-current circuit design. Only draws about 28 mA squelched receive and 500 mA transmit (at 1.5 W RF output).
- High-impact case and zinc die-cast frame.
- Compact and lightweight. Only 2-13/16 inches wide, 7-9/16 inches high, and 1-7/8 inches deep. Weighs only 1.62 pounds (including antenna, battery, and hand strap).

OPTIONAL ACCESSORIES:

- ST-1 Base Stand (provides 1.5-hour-quick, trickle, and floating charges, 4-pin microphone connector, and SO-239 antenna connector).
- BC-5 DC quick charger.
- LH-1 leather case.
- BH-1 belt hook.
- PB-24 extra NiCd battery pack.
- **NEW** SMC-24 speaker/mic.



for digital readout and scan option

Do thumbwheel switches that can't be seen at night irritate you? Are you frustrated when you know there are more than two repeaters in town and you can't find them? If the answer to these questions is "yes," then hold onto your armchair — you're about to read of a way to upgrade your old HW-2036 to include some of the features of the new Heathkit VF7401 2-meter fm digital scanning transceiver. This project takes the average Amateur two evenings to install and check out, which includes direct replacement of the Micoder™ board and installation of a board to replace the thumbwheel switches. Overall cost of the project shouldn't exceed \$55.00 (May, 1980), depending on your junk box.

circuit description

All frequency and Touch-Tone* information is entered through the microphone key pad, therefore I'll start the description with the 2036-MB micboard (fig. 1). Radio Shack National Parts has a 24-conductor microphone cable used on their One-Handler™ CB radio. This cable works just great for passing the required information on to HW-2036 and leaves room for expansion for future projects.

tone generation

Envision the 2036-MB micboard as two separate circuits on one board: one is the tone generator and the other is a BCD frequency generator. Touch-Tone™ generation occurs by depressing a keypad digit through which IC3 produces an audio tone at pins 2 and 15. These tones are coupled to the transmitter audio input. Operating voltage (+5Vdc) for IC3 is available to the chip on transmit only through the PTT switch.

frequency generation

The BDC frequency information is produced by a key depression in receive-mode only, which causes IC2 to generate five outputs. These are BDC informa-

*Touch-Tone is a registered trademark of the Bell System.

updating the Heathkit HW-2036

tion plus one strobe pulse bit. Binary-coded decimal is a means of counting from 0-9, A-F (table 1). Accompanying the BCD information to the 2036-DB (display board) is a strobe pulse, which indicates to the 2036-DB that a key has been depressed on the 2036-MB keypad. Nestled in this 2036-MB circuit is a NE-555, IC1. This chip produces a train of pulses that are proportional to the strobe pulse being present so many microseconds after key depression.

display board

To follow the path of data on the display board (fig. 2), imagine three separate areas: storage (SN74LS298), display (Fairchild 9368), and BCD-to-decimal conversion (IC1,2,3). Keyboard data (BCD A,B,C,D, and strobe) connect to the display board at IC7. The strobe inverts through IC2 then connects to all shift and storage registers (IC4,5,6,7). The storage register produces on its output lines whatever is presented to its input lines at the time of strobe pulse reception. Therefore, by connecting the output of one register to the input of an adjacent register and so on, a digit can be shifted through the registers one at a time with each strobe pulse received.

Surprisingly, the output of these registers is the input to the synthesizer and display drivers. Frequency display is accomplished by feeding the output BCD from IC4,5,6,7 to the 9368 decoder-driver chips. These chips (fig. 3) were used because of ease of adaptation and non-use of dropping resistors on the output lines. Connection is directly to the seven-segment display.

Creation of the 0/5-kHz signal is as follows. The BCD units digit is fed to IC3, which is a BCD-to-decimal converter. For every BCD digit input, a directly proportional decimal digit is output. I chose to use the digits from zero to four to indicate 0-kHz shift. A logic 1 on any one output of IC3 is inverted through IC2 and fed directly to IC1, a 5-input NOR gate. The output of NOR gate IC1 is connected to the HW-2036 synthesizer board at point X, fig. 2.

Scanning is accomplished by applying a pseudo

By Tom French, WA4BZP, Rt. 2, Suburban Shores, Winter Garden, Florida 32787

strobe pulse from IC4 (fig. 4) through the scan-operate switch to display-board, IC2 pin 13. ICs 1, 2, and 3 on the scan board are binary up-down counters and are arranged to facilitate counting up from 000-999. (Q213, located inside the HW-2036 on the receiver board, is tapped for the required signal to stop the scan operation.)

When Q1 (fig. 4) conducts, it forces pins 10 and 7 on IC1 to zero. This action locks the binary counters dead in their tracks. The amount of signal required to lock the scanner is varied by the value of R1, a 90k resistor. The higher its value, the more signal is required to stop the scanner. You might find that, when scanning, your HW-2036 stops 5-10 kHz before the repeater frequency is reached. This problem can be caused by a very strong signal and a low value for R1. My suggestion is to increase the value of R1 in fig. 4 at Q1 base. To re-enable scanning, simply depress the START SCAN button on the microphone.

Remove all knobs and external coverings. Keep the screws in a plastic cup so they won't get lost. The synthesizer lock LED is a tricky item. Be careful when removing the front panel subplate and bezel. Remove and save the thumbwheel switches and mounting screws. You'll need a red or any color plastic lens for the hole covering. Cut it to size with a

hacksaw blade and hold the plastic over the window where the display will go. Mark the four new mounting holes and drill them *slowly* into the plastic. Trim the edges as closely as possible and install the lens.

I used two 7805 voltage regulators to supply all required power to the display board and microphone board. Two holes must be drilled to accommodate installation of the 7805s. The first hole is beside the speaker just below the synthesizer board and display board (fig. 5).

Now is the tricky part: getting the second hole drilled. Pull the amplifier board a few inches away from the chassis (fig. 6) and drill *slowly* into the chassis. At this time it's best to install both 7805 voltage regulators as shown, remembering to use some silicone grease.

Reinstall the amplifier board then remove the microphone cable at both ends. It will be replaced by a 12-to-24-conductor cable. Place some type of insulation over the speaker connections and side magnet, preferably PVC electrical tape. This process helps keep the snug-fitting 2036-DB from short circuits. Use 6-32 x 2-1/4 inch (M 3/5 x 57 mm) countersunk mounting screw for the front hole, which will also hold the scan board, and a 6-32 x 1-1/4 inch (M 3/5 x 31.7 mm) screw for the 2036-DB rear hole.

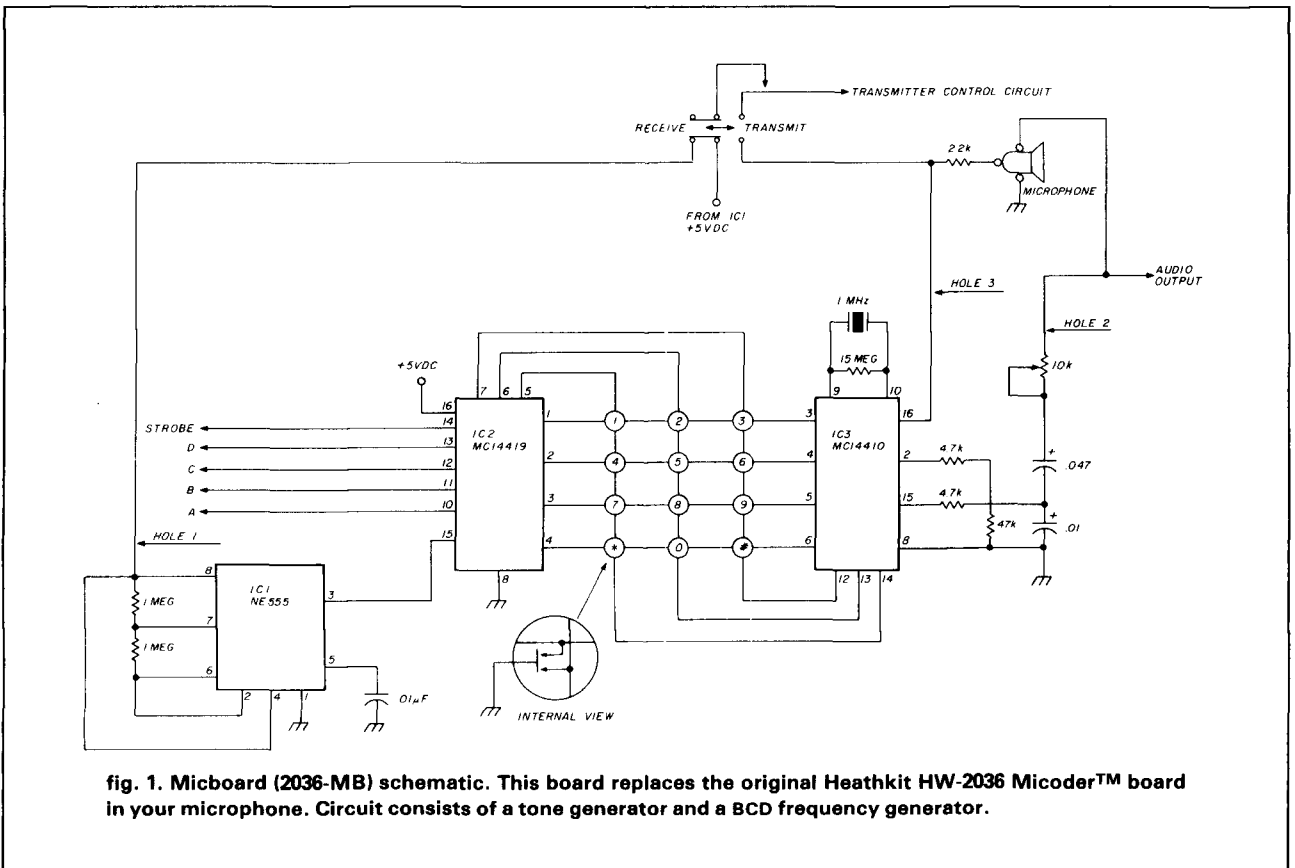

fig. 1. Micboard (2036-MB) schematic. This board replaces the original Heathkit HW-2036 Micoder™ board in your microphone. Circuit consists of a tone generator and a BCD frequency generator.

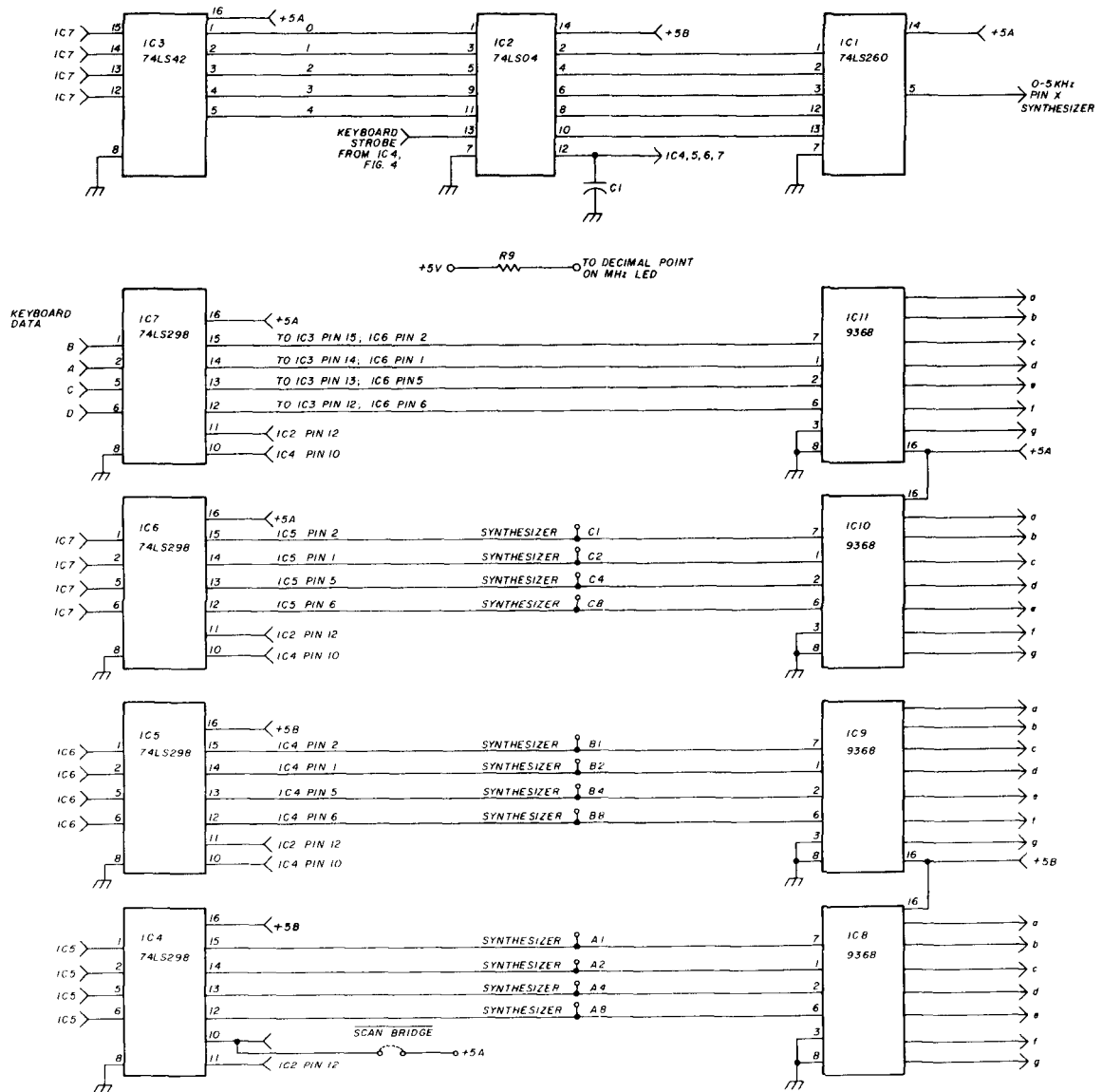

fig. 2. Display board (2036-DB). This board is positioned in the transceiver in the space previously occupied by the thumbwheel switches. The circuit provides storage, display, and BCD-to-decimal conversion.

micboard (2036-MB)

Remove all the parts from your microphone. Leave the microphone element and PTT switch within the plastic housing. Clean the terminal strip of all solder and wire debris. Install the one 2.2k resistor to one side of the microphone element (fig. 7) and the other end to +5Vdc on TRANSMIT. Remove all the old keypad pin sockets from your old micboard and reinstall on the 2036-MB.

Install all chips on the component side of the board. Pins 8,8,1 of the MC14410, 14419, and NE-555 respectively connect to the ground plane. Note that the .01 μ F and .047 μ F caps are electrolytic; observe polarity.

Parts that go on the underside of the board are the 1-MHz crystal and a .01- μ F disc clock capacitor.

The next step is to cable the microphone, trying to follow some kind of plan on signal-to-color coordination (fig. 8). On the 2036-MB and PTT switch connect a wire to each of the following: +5 Vdc on

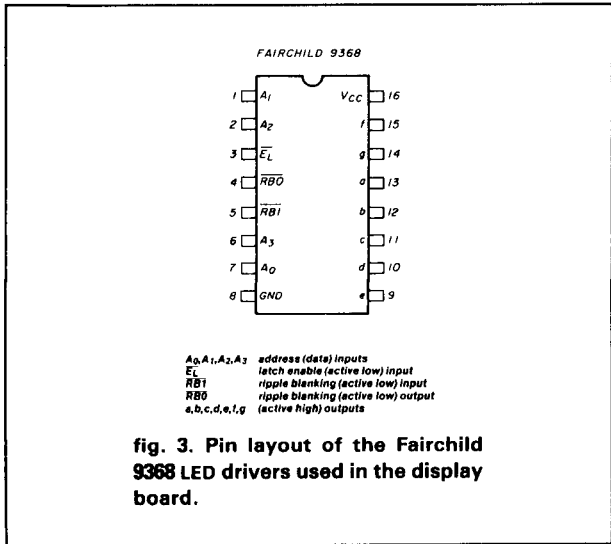
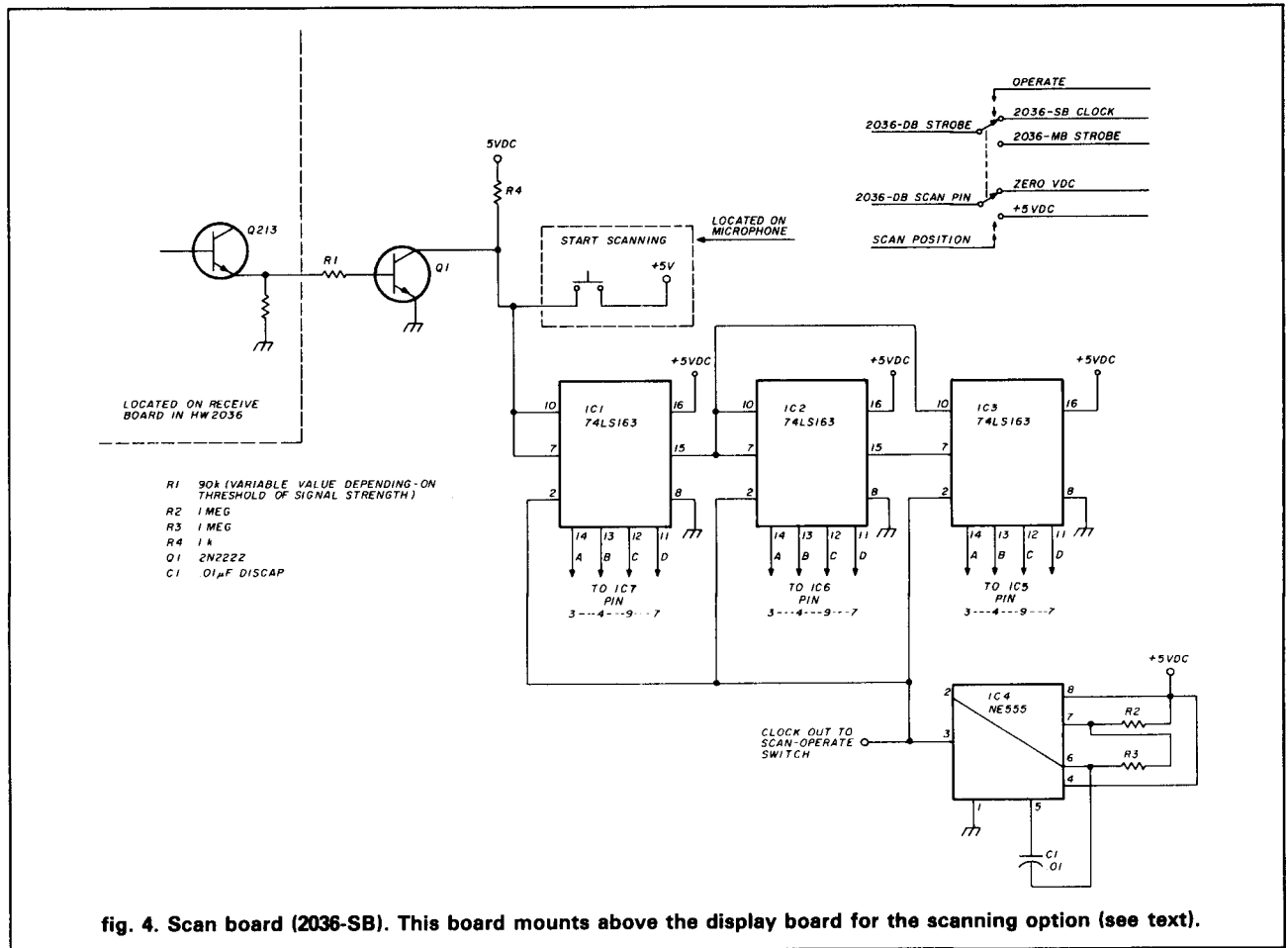

table 1. Binary-coded decimal format representing the 2036-MB micboard output. Valid outputs are from zero to nine.

	A	B	C	D	
0	0	0	0	0	1 = +5 Vdc
1	1	0	0	0	0 = 0 Vdc
2	0	1	0	0	
3	1	1	0	0	
4	0	0	1	0	
5	1	0	1	0	
6	0	1	1	0	
7	1	1	1	0	
8	0	0	0	1	
9	1	0	0	1	
A	0	1	0	1	
B	1	1	0	1	
C	0	0	1	1	
D	1	0	1	1	
E	0	1	1	1	
F	1	1	1	1	



TRANSMIT, +5 Vdc on RECEIVE, +5 Vdc ground. On the micboard, pin 3 is labeled +5 Vdc on TRANSMIT; pin 1 +5 Vdc on RECEIVE. Pin 2 is the audio output. Power for all circuits in the microphone is obtained from the 7805 (IC1) originally in the rig (fig. 10).

display board (2036-DB)

Molex pins or low-profile IC sockets may be used on this board. R9 is a 200-ohm resistor to enable the decimal point on the display. Install it and connect a wire to one end for further connection to the mega-

hertz LED. Capacitor C1 is installed if double or triple digiting happens when the key pad is pressed (fig. 9). Whether or not your SN74LS298 chips match has a direct bearing on the need for C1; its range is between 100 μ F-470 pF. To test all of the LEDs after installation, just key in four "eights."

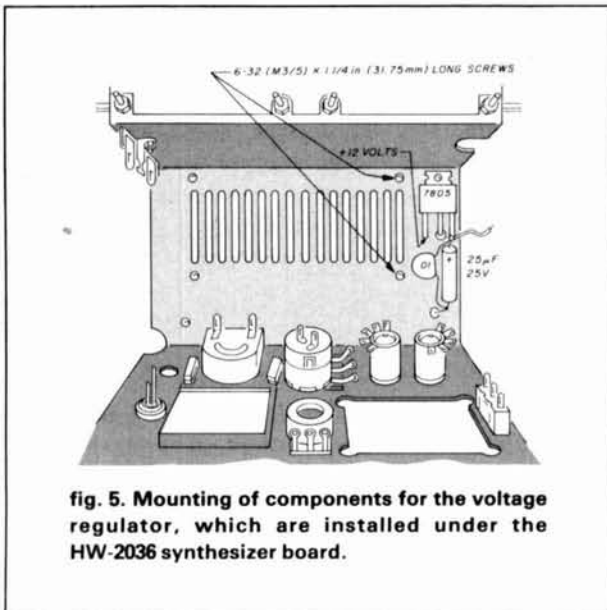

fig. 5. Mounting of components for the voltage regulator, which are installed under the HW-2036 synthesizer board.

HW-2036 synthesizer board

Our next adventure starts on the HW-2036 synthesizer board. Very carefully remove all the pull-up resistors associated with the thumbwheel switches: R401-R409, R411-413. Install a small solder bridge on the 2036-DB, at the scan bridge to pin 10 of IC7 if not using the scan option (fig. 9). A small piece of wire with five leads should be run from the microphone cable to the display board for strobe and BCD data. No shielding is required here. Run the wire beneath

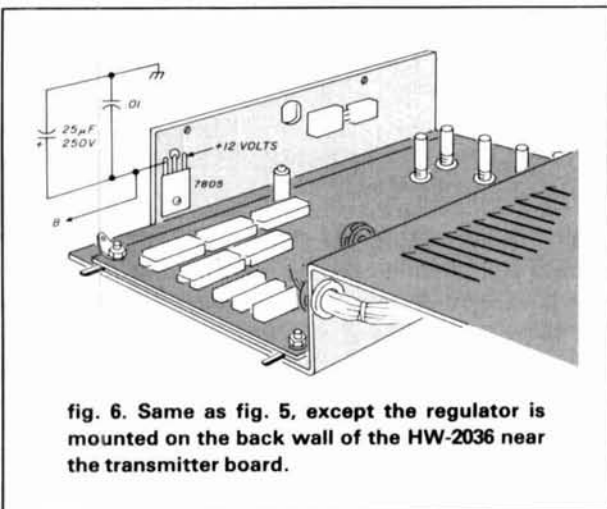

fig. 6. Same as fig. 5, except the regulator is mounted on the back wall of the HW-2036 near the transmitter board.

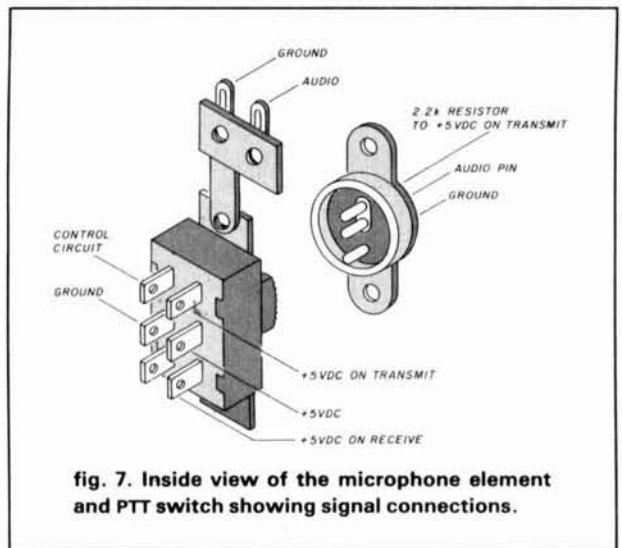

fig. 7. Inside view of the microphone element and PTT switch showing signal connections.

the volume control and mode switches. All common cathode LEDs should be mounted about 1/4 inch (6.5 mm) above the 2036-DB surface. A piece of balsa wood or plastic can be used for this task.

Install the 2036-DB board, and with a pencil mark the window center position. Then super glue the LEDs to the board. Install the 25- μ F, 25-Vdc and the

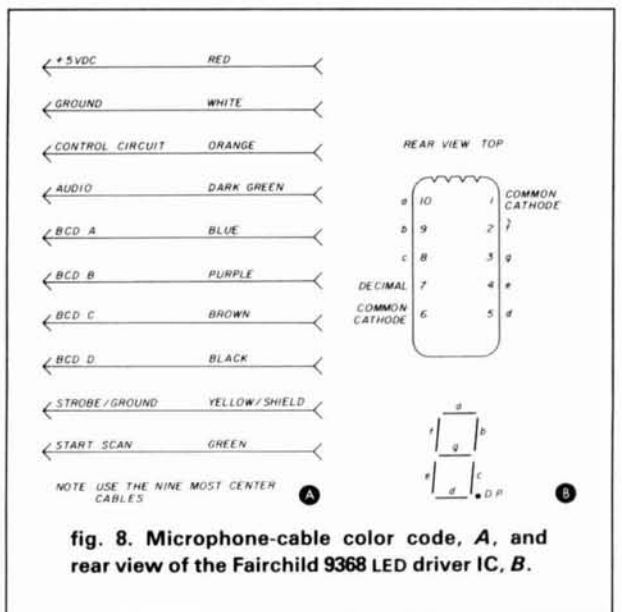

fig. 8. Microphone-cable color code, A, and rear view of the Fairchild 9368 LED driver IC, B.

.01 μ F capacitors to both 7805 voltage regulators.

Connect the rear 7805 to the B power pin and the front 7805 to the A power pin (fig. 10). All common cathodes of the LEDs can be daisy-chained, then one end can be connected to ground. The wires to the thumbwheel switches should be resoldered to their corresponding drivers at locations A-B-C-D. For IC8, pins 7 and 1 are points A1 and A2 respectively on the

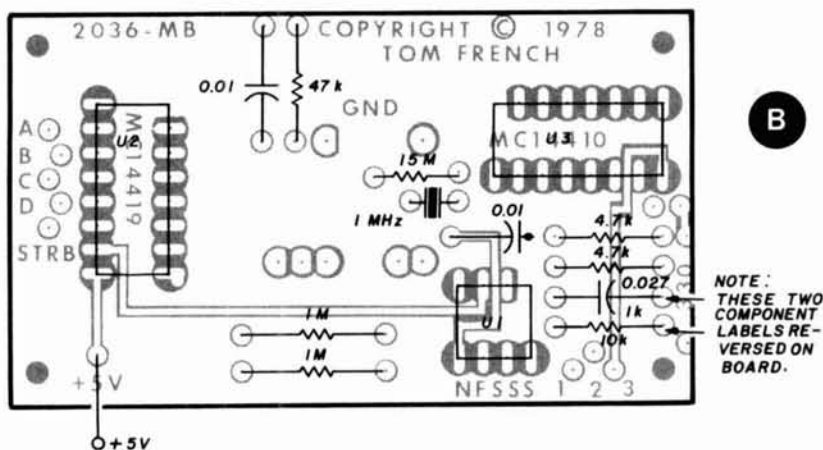
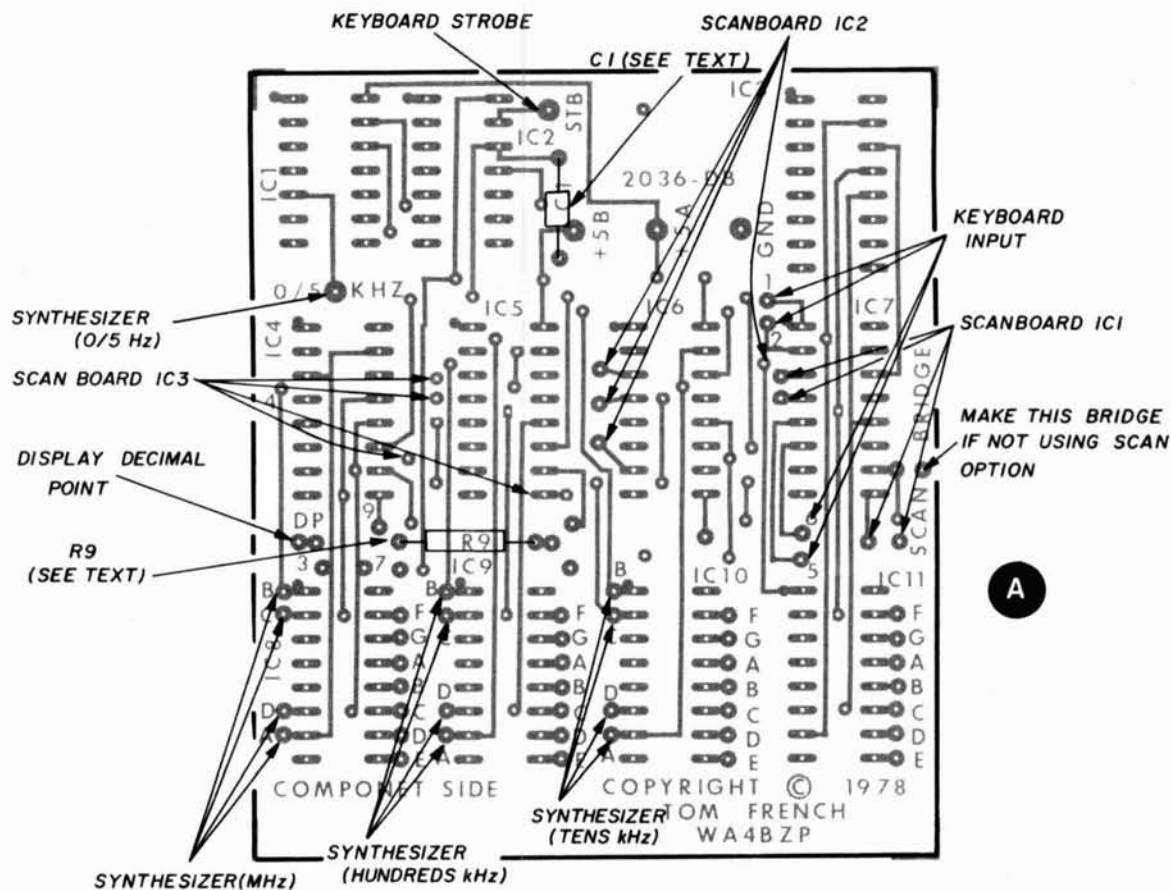

fig. 9. Layout of the display board (2036-DB), A, and the micboard (2036-MB) B, showing corrections. (Labels were reversed on the latter PC board.)

synthesizer board. IC10 displays the tens of kilohertz; IC11 kilohertz (fig. 2).

scan board (2036-SB)

This scan board mounts forward on the 6-32 x 2-1/4-inch (M 3/5 x 57 mm) screw. The scan board is built on a piece of perf board. Install all chips and transistor Q1 with resistor R1. Clock-out from the NE555 goes to the scan-operate switch (0/5 kHz) to provide a strobe pulse to the SN74LS298s. When scanning, if your synthesizer isn't locking onto frequency, the clock frequency of IC4 on the 2036-SB should be slowed down by increasing the values of R1 and R2 to above 1 meg. The leads from IC1-IC3 of

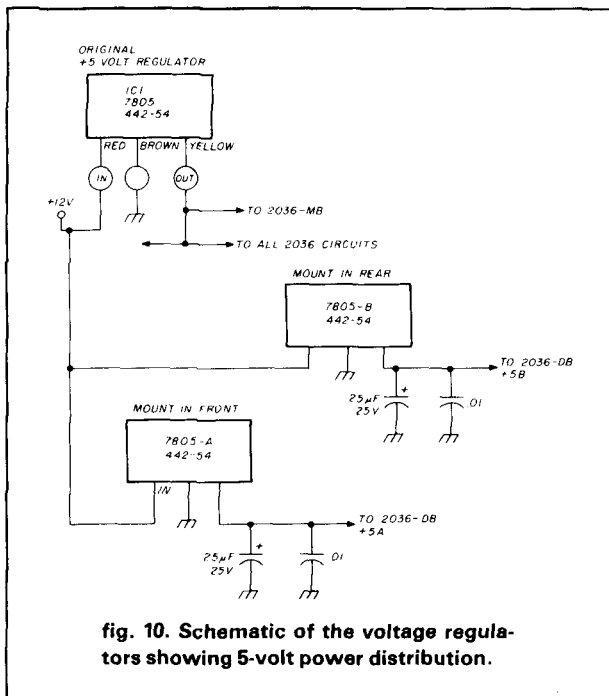

fig. 10. Schematic of the voltage regulators showing 5-volt power distribution.

the scan board should be connected to the display board using wire wrap.

Wiring the scan/operate switch is next. The 2036-DB strobe is connected to the center pole of one side of this switch. To scan 147.000-147.999 MHz, key in 7-7-7-7, then switch to scan. The switch should be toggled slowly. This scan modification facilitates the location of new repeaters in a new city. By no means is it competitive with professional scanners.

checkout

Complete all connections and reassemble, leaving the skins off. For that matter, you can leave the display board out and to the side of your rig. (No need to hook up the synthesizer wires until the 2036-DB is operational.) Assuming you've done all the above correctly, we're ready to power up. The display will

read some random numbers and sometimes even letters.

On the 2036-MB check the NE-555 pin 8 and MC14419 pin 16 for +5 Vdc. If it's present, we'll assume pin 3 of the NE-555 is generating a clock pulse. There are two key strokes considered by the keypad to be invalid in the receive mode. They are # and *. This being true, they will not generate a bit pattern upon key depression, only in receive mode.

Depress some digits. Your display should follow from right to left; if not, let's troubleshoot it. When you depress a valid key, the strobe pulse should appear on the output of MC14419 pin 14. A scope or logic probe is required to view this signal, as it is very short in duration. As long as you hold your finger on the keypad digit, the output loads (A-B-C-D) of MC14419 will represent the desired digit. If not, check all voltages in your micboard and repair. The keypad data and strobe are sent to IC7 on the 2036-DB. At IC7, which is the kHz digit, the BCD data is sent to decimal converter IC3. It will generate a logic one if the BCD input is between zero and four and a logic zero if it is between five and nine. The signal is inverted at IC2 then sent to a five-input NOR gate for the final 0/5 kHz output. A logic zero is equal to zero kHz, and a logic one equals 5-kHz shift up.

On displaying your operating frequency, suppose you desire 147.345 MHz. Simply touch in the digit sequence 7-3-4-5 on the keypad. Upon depressing the push-to-talk switch, the keypad is now a Touch-Tone™ pad and will generate the standard phone tones.

concluding remarks

The mic-Touch-Tone™ kit is available from Data Signal Incorporated labeled EK-2036. It includes a 1-MHz crystal, MC14410 Touch-Tone™ encoder, and various capacitors and components. This kit is required only if your Micoder™ doesn't have the Motorola Touch-Tone™ encoder. Heathkit used the Mostek chip in some versions of the Micoder 2™, so check it carefully.

Circuit-board artwork is included for the daring individuals who are familiar with double-sided etching. For those who are not so well off, the author supplies one 2036-MB and one 2036-DB with instructions for \$19.95. The 2036-SB (scan board) must be built on perf board, as designing a board was not feasible at the time of this writing.

bibliography

Stephens, Bill, WB8TJL, "Outboard LED Frequency Display for the HW-2036," *ham radio*, July, 1978, page 50.

ham radio

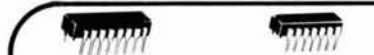

7400		
SN7400N	-25	
SN7401N	-25	
SN7402N	-25	
SN7403N	-25	SN7402N
SN7404N	-25	SN7403N
SN7405N	-25	SN7404N
SN7406N	-25	SN7405N
SN7407N	-25	SN7406N
SN7408N	-25	SN7407N
SN7409N	-25	SN7408N
SN7410N	-25	SN7409N
SN7411N	-25	SN7410N
SN7412N	-25	SN7411N
SN7413N	-25	SN7412N
SN7414N	-25	SN7413N
SN7415N	-25	SN7414N
SN7416N	-25	SN7415N
SN7417N	-25	SN7416N
SN7418N	-25	SN7417N
SN7419N	-25	SN7418N
SN7420N	-25	SN7419N
SN7421N	-25	SN7420N
SN7422N	-25	SN7421N
SN7423N	-25	SN7422N
SN7424N	-25	SN7423N
SN7425N	-25	SN7424N
SN7426N	-25	SN7425N
SN7427N	-25	SN7426N
SN7428N	-25	SN7427N
SN7429N	-25	SN7428N
SN7430N	-25	SN7429N
SN7431N	-25	SN7430N
SN7432N	-25	SN7431N
SN7433N	-25	SN7432N
SN7434N	-25	SN7433N
SN7435N	-25	SN7434N
SN7436N	-25	SN7435N
SN7437N	-25	SN7436N
SN7438N	-25	SN7437N
SN7439N	-25	SN7438N
SN7440N	-25	SN7439N
SN7441N	-25	SN7440N
SN7442N	-25	SN7441N
SN7443N	-25	SN7442N
SN7444N	-25	SN7443N
SN7445N	-25	SN7444N
SN7446N	-25	SN7445N
SN7447N	-25	SN7446N
SN7448N	-25	SN7447N
SN7449N	-25	SN7448N
SN7450N	-25	SN7449N
SN7451N	-25	SN7450N
SN7452N	-25	SN7451N
SN7453N	-25	SN7452N
SN7454N	-25	SN7453N
SN7455N	-25	SN7454N
SN7456N	-25	SN7455N
SN7457N	-25	SN7456N
SN7458N	-25	SN7457N
SN7459N	-25	SN7458N
SN7460N	-25	SN7459N
SN7461N	-25	SN7460N
SN7462N	-25	SN7461N
SN7463N	-25	SN7462N
SN7464N	-25	SN7463N
SN7465N	-25	SN7464N
SN7466N	-25	SN7465N
SN7467N	-25	SN7466N
SN7468N	-25	SN7467N
SN7469N	-25	SN7468N
SN7470N	-25	SN7469N

74LS		
HL500	-29	
HL501	-29	
HL502	-29	
HL503	-29	
HL504	-29	
HL505	-29	
HL506	-29	
HL507	-29	
HL508	-29	
HL509	-29	
HL510	-29	
HL511	-29	
HL512	-29	
HL513	-29	
HL514	-29	
HL515	-29	
HL516	-29	
HL517	-29	
HL518	-29	
HL519	-29	
HL520	-29	
HL521	-29	
HL522	-29	
HL523	-29	
HL524	-29	
HL525	-29	
HL526	-29	
HL527	-29	
HL528	-29	
HL529	-29	
HL530	-29	
HL531	-29	
HL532	-29	
HL533	-29	
HL534	-29	
HL535	-29	
HL536	-29	
HL537	-29	
HL538	-29	
HL539	-29	
HL540	-29	
HL541	-29	
HL542	-29	
HL543	-29	
HL544	-29	
HL545	-29	
HL546	-29	
HL547	-29	
HL548	-29	
HL549	-29	
HL550	-29	
HL551	-29	
HL552	-29	
HL553	-29	
HL554	-29	
HL555	-29	
HL556	-29	
HL557	-29	
HL558	-29	
HL559	-29	
HL560	-29	

74S		
74S00	-50	
74S01	-50	
74S02	-50	
74S03	-50	
74S04	-50	
74S05	-50	
74S06	-50	
74S07	-50	
74S08	-50	
74S09	-50	
74S10	-50	
74S11	-50	
74S12	-50	
74S13	-50	
74S14	-50	
74S15	-50	
74S16	-50	
74S17	-50	
74S18	-50	
74S19	-50	
74S20	-50	
74S21	-50	
74S22	-50	
74S23	-50	
74S24	-50	
74S25	-50	
74S26	-50	
74S27	-50	
74S28	-50	
74S29	-50	
74S30	-50	
74S31	-50	
74S32	-50	
74S33	-50	
74S34	-50	
74S35	-50	
74S36	-50	
74S37	-50	
74S38	-50	
74S39	-50	
74S40	-50	
74S41	-50	
74S42	-50	
74S43	-50	
74S44	-50	
74S45	-50	
74S46	-50	
74S47	-50	
74S48	-50	
74S49	-50	
74S50	-50	

CA-LINEAR		
CA301H	2.15	
CA302H	1.25	
CA303H	1.25	
CA304H	1.25	
CA305H	1.25	
CA306H	1.25	
CA307H	1.25	
CA308H	1.25	
CA309H	1.25	
CA310H	1.25	
CA311H	1.25	
CA312H	1.25	
CA313H	1.25	
CA314H	1.25	
CA315H	1.25	
CA316H	1.25	
CA317H	1.25	
CA318H	1.25	
CA319H	1.25	
CA320H	1.25	
CA321H	1.25	
CA322H	1.25	
CA323H	1.25	
CA324H	1.25	
CA325H	1.25	
CA326H	1.25	
CA327H	1.25	
CA328H	1.25	
CA329H	1.25	
CA330H	1.25	
CA331H	1.25	
CA332H	1.25	
CA333H	1.25	
CA334H	1.25	
CA335H	1.25	
CA336H	1.25	
CA337H	1.25	
CA338H	1.25	
CA339H	1.25	
CA340H	1.25	
CA341H	1.25	
CA342H	1.25	
CA343H	1.25	
CA344H	1.25	
CA345H	1.25	
CA346H	1.25	
CA347H	1.25	
CA348H	1.25	
CA349H	1.25	
CA350H	1.25	

CD-CMOS		
CD4000	-39	
CD4001	-39	
CD4002	-39	
CD4003	-39	
CD4004	-39	
CD4005	-39	
CD4006	-39	
CD4007	-39	
CD4008	-39	
CD4009	-39	
CD4010	-39	
CD4011	-39	
CD4012	-39	
CD4013	-39	
CD4014	-39	
CD4015	-39	
CD4016	-39	
CD4017	-39	
CD4018	-39	
CD4019	-39	
CD4020	-39	
CD4021	-39	
CD4022	-39	
CD4023	-39	
CD4024	-39	
CD4025	-39	
CD4026	-39	
CD4027	-39	
CD4028	-39	
CD4029	-39	
CD4030	-39	
CD4031	-39	
CD4032	-39	
CD4033	-39	
CD4034	-39	
CD4035	-39	
CD4036	-39	
CD4037	-39	
CD4038	-39	
CD4039	-39	
CD4040	-39	

J608 PROGRAMMER 2708 EPROM PROGRAMMER



The J608 EPROM Programmer is a completely self-contained unit which is independent of computer control and requires no auxiliary systems for its operation. The EPROM can be programmed from the Hexadecimal Keyboard or from a pre-programmed EPROM. The J608 Programmer can emulate a programmer EPROM by the use of its internal RAM processor. This will allow the user to test or program a program for a system, prior to programming a chip. Any changes in the program can be entered directly, onto the memory circuit with the Hexadecimal Keyboard at that time entering the entire program will not be necessary. The J608 Programmer contains a programmer board with 25 IC's and including power supplies of -5V, +5V, +12V and +20V. The Hexadecimal Keyboard and LED Test Socket Panel Board are separate assemblies within the system.

J608 KIT \$399.95
J608A Assembled and tested \$499.95

DISCRETE LEADS

XC556G 200' red	4/51	MV50 085' red	6/51	XC111H 190' red	6/51
XC556G 200' green	4/51	XC209G 125' green	4/51	XC111G 190' green	4/51
XC556G 200' yellow	4/51	XC209Y 125' yellow	4/51	XC111Y 190' yellow	4/51
XC556G 200' clear	4/51	XC209C 125' clear	4/51	XC111C 190' clear	4/51
XC22R 200' red	5/51	XC528R 185' red	5/51	INFRA-RED LED 1/2" x 1/4" x 1/16" flat	
XC22G 200' green	4/51	XC528G 185' green	4/51	IRL - 3/51	
XC22Y 200' yellow	4/51	XC528Y 185' yellow	4/51		
MV10B 170' red	4/51				

DISPLAY LEADS

C.A. - Common Anode			C.C. - Common Cathode		
Type	Polarity	Ht. Price	Type	Polarity	Ht. Price
MAN 1	C.A.-red	270 2.95	DL741	C.C.-red	600 1.25
MAN 2	S-7 D.M.-red	300 4.95	DL746	C.C.-red 1	530 1.49
MAN 3	C.C.-red	125 25	DL747	C.C.-red	600 1.49
MAN 4	C.C.-green	300 1.25	DL750	C.C.-red	600 1.49
MAN 5	C.C.-green	300 1.25	DL758	C.C.-red	110 25
MAN 6	C.C.-red	300 75	FND750	C.C.-red	250 69
MAN 7	C.C.-red	300 75	FND750	C.C.-1	367 99
MAN 8	C.C.-red	300 1.25	FND759	C.C.	357 75
MAN 82	C.A.-yellow	300 49	FND500	C.C.	500 99
MAN 84	C.C.-yellow	300 99	FND500	C.C. (FND510)	500 99
MAN 3620	C.A.-orange	300 49	HDS3401	C.C.	300 1.50
MAN 3530	C.A.-orange 1	300 99	HDS3403	C.C.	600 1.50
MAN 3640	C.C.-orange	300 99	5082-763	C.C.,R.H.D.-red	300 1.25
MAN 4610	C.A.-orange	400 99	5082-7620	C.A.,L.H.D.-yel.	300 1.25
MAN 6610	C.A.-orange-DD	560 99	5082-7623	C.C.,R.H.D. yel.	300 1.25
MAN 6630	C.A.-orange 1	560 99	5082-7730	C.A.,L.H.D.-red	300 1.25
MAN 6640	C.C.-orange-DD	560 99	5082-7731	C.A.,R.H.D.-red	300 1.25
MAN 6650	C.C.-orange 1	560 99	5082-7750	C.A.,L.H.D.-red	430 1.75
MAN 6660	C.C.-orange	560 99	5082-7751	C.C.,R.H.D.-red	430 1.75
MAN 6710	C.C.-red	560 99	5082-7760	C.C.,R.H.D.-DD	430 1.75
MAN 6750	C.C.-red 1	560 99	5082-7000	4x7 sqd. dig. RHD	600 22.00
MAN 6780	C.C.-red	560 99	5082-7002	4x7 sqd. dig. LHD	600 22.00
DL704	C.C.-red	300 1.25	5082-7004	Overdrive char. (1:1)	500 19.95
DL707	C.C.-red	300 75	L1711	Photo Xsistor Opto-Isol.	69
DL728	C.C.-red	500 1.49	MOC3010	Optically Isol. Triac Driver	1.25

RADIO CONTROL CIRCUITS

Ideal for remote control systems which use pulse amplitude modulation (toy cars, boats, tanks, etc.) Features: five function control, adjustable steering angle, suitable for 27 and 43MHz bands and low power consumption.

NEW!

KB-428 TRANSMITTER \$4.25
Abs. max. rating (TA95°C): Supply volt.: Vcc1 12VDC
Power Dissip.: PDI 300mW; Temp. range: Oper. 0-50°C
S.W. Power Dissip.: 500mW; Temp. range: Oper. 0-50°C
CR Oscillation circuits acceptable.

KB-429 RECEIVER \$5.95
Abs. max. rating (TA95°C): Supply volt.: Vcc1 11V, Vcc2 5V
S.W. Power Dissip.: 600mW; Temp. range: Oper. 0-50°C
Rec. oper. volt.: VOPI 7-11V - VOPI 3-6V.

LOW PROFILE (TIN) SOCKETS			SOLDERTAIL STANDARD (TIN)		
1-24	25-49	50-100	1-24	25-49	50-100
8 pin LP	17	16	15	14	13
14 pin LP	20	19	18	17	16
16 pin LP	22	21	20	19	18
18 pin LP	24	23	22	21	20
20 pin LP	26	25	24	23	22
22 pin LP	27	26	25	24	23
24 pin LP	28	27	26	25	24
28 pin LP	35	34	33	32	31
40 pin LP	63	62	61	60	59

SOLDERTAIL (GOLD) STANDARD			WIRE WRAP SOCKETS (GOLD) LEVEL #3		
1-24	25-49	50-100	1-24	25-49	50-100
8 pin SG	39	35	16 pin WW	85	77
14 pin SG	49	45	18 pin WW	99	91
16 pin SG	54	49	20 pin WW	119	108
18 pin SG	59	53	22 pin WW	139	123
24 pin SG	79	75	24 pin WW	149	135

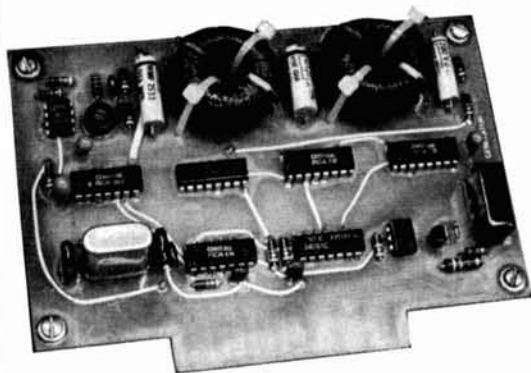

the XK2C AFSK generator

Introducing a CMOS version
of the Mainline XK2 —
a spinoff design
offering low power consumption

The AFSK generator described in this article is a low-power CMOS version of the Mainline XK2.¹ The XK2, using TTL devices, required approximately 150 mA at 5 Vdc. The XK2C will operate from a 10-15 Vdc supply; at 12 Vdc it draws only 8 mA, including the additional audio driver stage (fig. 1).

device compatibility

The basic logic of the XK2C is the same as that of its predecessor. However, as Murphy's law would indicate, things are not as simple as direct substitution of CMOS ICs for TTL devices. CMOS operation is slower than that of TTL (about one-quarter as fast at 5 Vdc).

propagation delay

Propagation delay through the programmable divider logic can easily exceed the time for one cycle of the clock, thereby skipping clock pulses and yielding an erratic output frequency. Three steps were taken to get around this problem. First, the clock frequency was reduced to 1606.5 kHz (one-half the TTL clock) and the final divide-by-two stage was eliminated. This provided the same output frequencies while allowing the programmable divider to function at one-half the rate. Second, the number of logic gates for the divider preset was held to a minimum. The preset input polarity for the CD4516 (fig. 2) is opposite to that required for the original 74193s, so an AND gate was required for proper preset. Third, the input voltage was raised to 10 Vdc minimum because CMOS operates faster at higher supply voltages.

power-supply voltages

Operation from a 5-Vdc supply may well be possible, depending on the propagation delays of the chips used and the temperature range over which they will be operated. If 5 Vdc operation is desired, the output frequency should be closely checked with a frequency counter over the desired operating temperature range. The output frequencies should be stable at 2125 Hz, 2295 Hz and 2975 Hz. Propaga-

By Robert W. Lewis, W3HVK, P.O. Box 41,
Stevensville, Maryland 21666

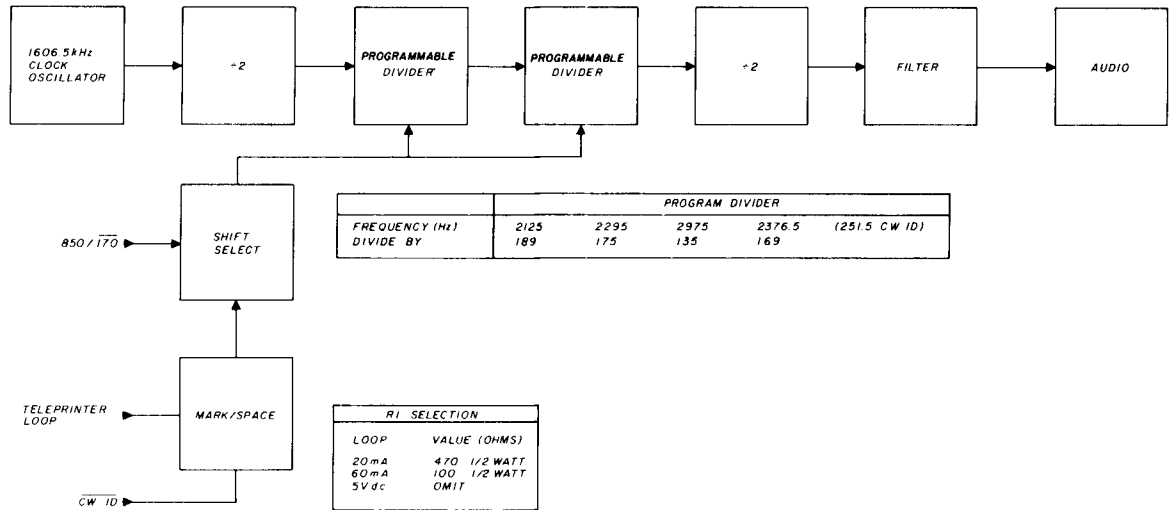

fig. 1. Block diagram of the XK2C crystal Mainline AFSK generator. Power consumption is low; at 12 Vdc circuit draws only 8 mA, even with the added audio driver stage.

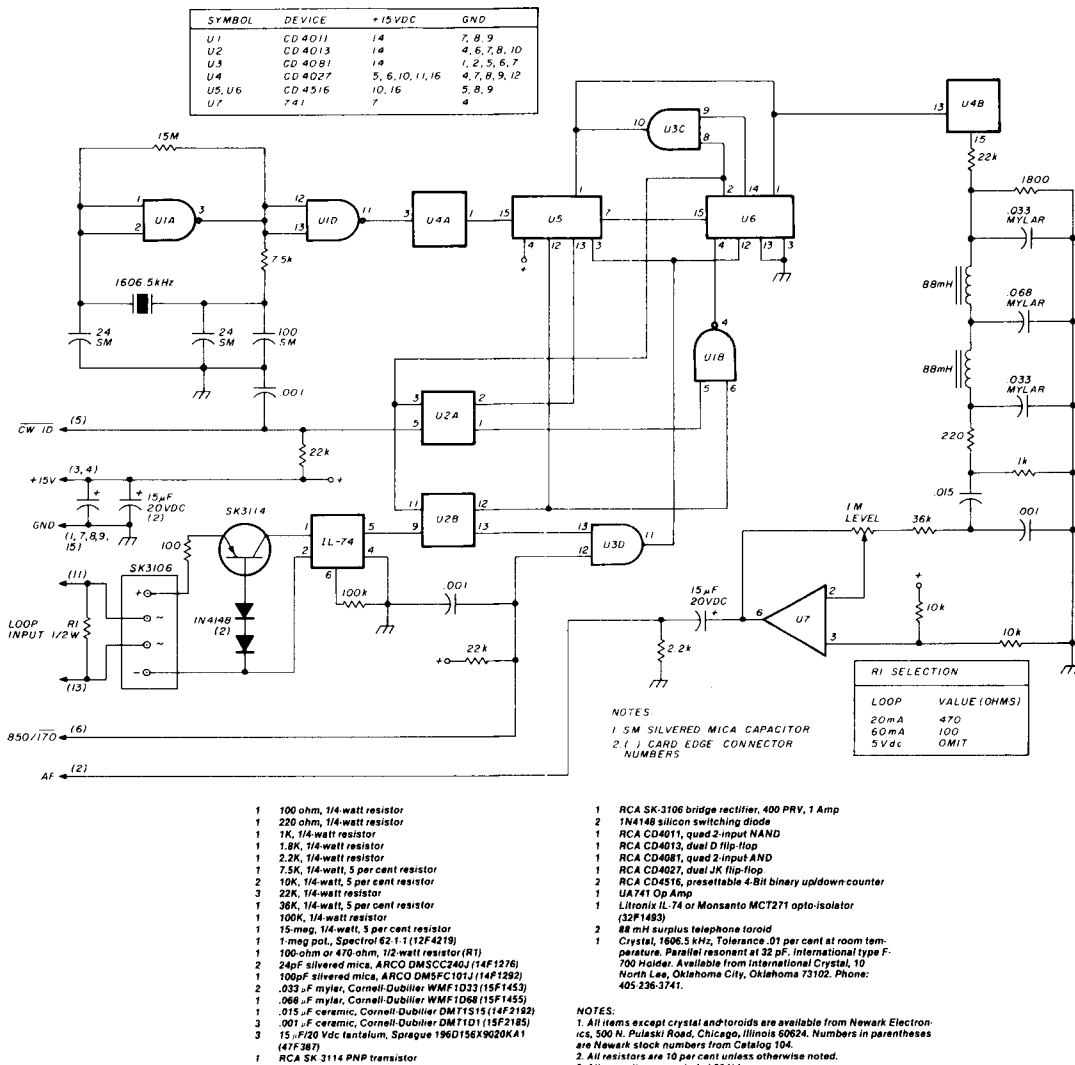

fig. 2. Schematic of the XK2C AFSK generator. Operation from a 5-Vdc supply may be possible, depending on several factors (see text).

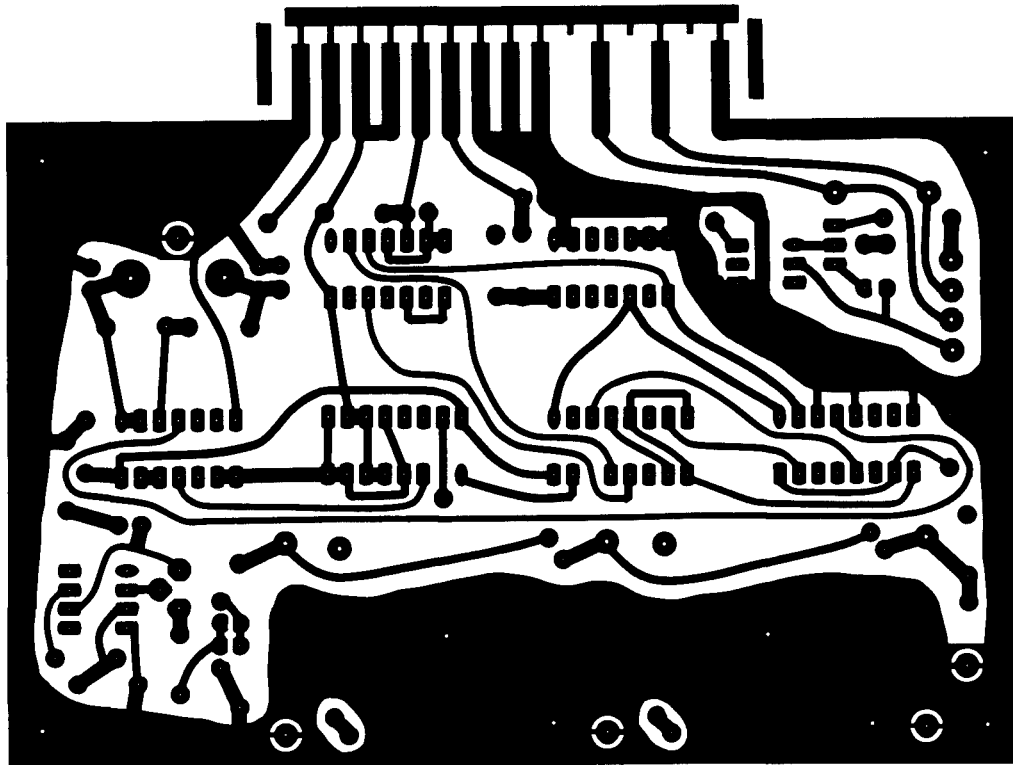

fig. 5. Non-component side of PC board.

tion delays may cause one clock pulse to skip for each preset of the programmable divider, thereby yielding outputs of 2114 Hz, 2282 Hz, and 2953 Hz respectively. At 10-Vdc or more, worst-case propagation delays won't be great enough to cause difficulties.

Elimination of the final divide-by-two stage left one clocked D latch (one-half of a CD-4013) unused. I decided to use this latch to clock in the CW ID data, thereby making it coherent, as with the TTY data. This doesn't really buy anything, but it was available and eliminates the need for one inverter, since both Q and \bar{Q} outputs are available from the latch.

Shift-selection logic was added so that the 170-Hz or 850-Hz selection could be made with a spst switch instead of the spdt switch required by the XK2. I added an audio driver stage (UA741 op amp) to provide plenty of output signal and a good, stiff source capable of driving low- as well as high-impedance transmitter audio inputs. I added a loop-to-logic converter (SK3106, SK3114, and IL74) for direct connection into the teleprinter loop. This input is isolated from ground and will operate with either polarity current.

The value of $R1$ was selected from fig. 1 for keying from either a 20-mA or 60-mA loop; or $R1$ may be

deleted altogether for keying directly across a 5-Vdc supply. High-voltage loops (100-200 Vdc), with selector magnets directly in line, often generate spikes and rf hash, which could get into the XK2C logic. The PC board has been designed so that the loop-to-logic converter can be easily shielded if required. The PC board plugs into a Cinch type 50-15A-20, 15-pin receptacle.

assembly

The XK2C was assembled on a double-sided, plug-in PC board (figs. 4 and 5). Since it was not possible for me to make plated-through holes, it was necessary to solder the components to the foil on both sides of the board. Care must be taken not to overheat the ICs during soldering.

The XK2C has all the features of the earlier XK2 plus a few extra, and it offers a considerable savings in power consumption.

reference

1. Irving Hoff, W6FCC, "The Mainline XK2 Crystal AFSK," *RTTY Journal*, July-August, 1976, page 3.

ham radio

DRAKE 7-Line Family

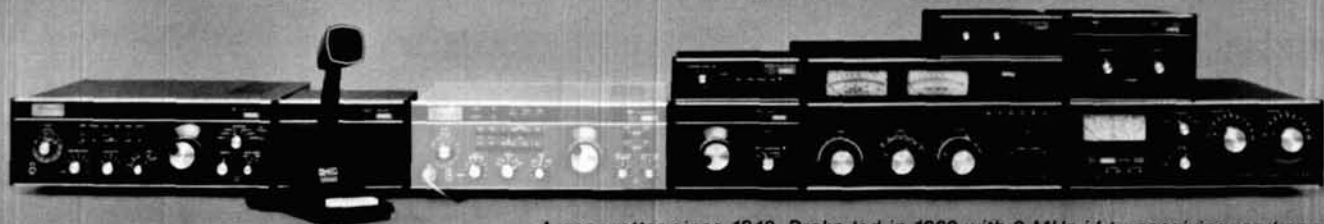

A pacesetter since 1943, Drake led in 1963 with 9 MHz i-f transceiving, and now with 48 MHz i-f "Up Conversion" . . . Drake brings you tomorrow's state of the art today.



Model 1336

TR7

**solid state
continuous coverage
synthesized hf system**

Continuous Frequency Coverage—The TR7 provides continuous coverage in receive from 1.5 to 30 MHz. Transmit coverage is provided for all amateur bands from 160 through 10 meters. The optional AUX7 Range Program Board allows out-of-band transmit coverage for MARS, Embassy, Government and Commercial services as well as future band expansions in the 1.8 through 30 MHz range.* The AUX7 Board also provides 0 through 1.5 MHz receive coverage and crystal-controlled fixed-channel operation for Government, Amateur or Commercial applications anywhere in the 1.8 to 30 MHz range.

Synthesized/PTO Frequency Control—A Drake exclusive: carefully engineered high-performance synthesizer, combined with the famous Drake PTO, provides smooth, linear tuning with 1 kHz dial and 100 Hz digital readout resolution. 500 kHz up/down range switching is pushbutton controlled.

Advanced, High-Performance Receiver Design—The receiver section of the Drake TR7 is an advanced, up-conversion design. The first intermediate frequency of 48.05 MHz places the image frequency well outside the receiver input passband, and provides for true general coverage operation without i-f gaps or crossovers. In addition, the receiver section features a high-level double balanced mixer in the front end for superior spurious and dynamic range performance.

True Passband Tuning—The TR7 employs the famous Drake full passband tuning instead of the limited range "i-f shift" found in some other units. The Drake system allows the receiver passband to be varied from the top edge of one sideband, through center, to the bottom edge of the opposite sideband. In fact, the range is even wider to accommodate RTTY. This system greatly improves receiving performance in heavy QRM by

allowing the operator to move interfering signals out of the passband, and it is so flexible that you can even transmit on one sideband and listen on the other.

Unique Independent Receiver Selectivity—Space is provided in the TR7 for up to 3 optional crystal filters. These filters are selected, along with the standard 2.3 kHz filter, by front panel pushbutton control, independent of the mode control. This permits the receive response to be optimized for various operating conditions in any operational situation. Optional filter bandwidths include 6 kHz for a-m, 1.8 kHz for narrow ssb or RTTY, and 500 Hz and 300 Hz for cw.

Broadband, Solid State Design—100% solid state throughout. All circuits are broadbanded, eliminating the need for tuning adjustments of any kind. Merely select the correct band, dial up the desired frequency, and you're ready to operate.

Rugged, Solid State Power Amplifier—The power amplifier is internally mounted, with nothing outboard subject to physical damage. A Drake designed custom heat sink makes this possible. The unique air ducting design of this heat sink allows an optional rear-mounted fan, the FA7, to provide continuous, full power transmit on SSTV/RTTY. The fan is not required for ssb/cw operation, since normal convection cooling allows continuous transmit in these modes.

Effective Noise Blanker—The optional NB7 Noise Blanker plugs into the TR7 to provide true impulse-type noise blanking performance. This unit is carefully designed to maximize both blanking and dynamic range in order to preserve the excellent strong-signal handling characteristics of the TR7.

* NOTE: Transmitter coverage for MARS, Government, and future WARC bands is available only in ranges authorized by the FCC, Military, or other government agency for a specific service. Proof of license for that service must be submitted to the R. L. Drake Company, including the 500 kHz range to be covered. Upon approval, and at the discretion of the R. L. Drake Company, a special range IC will be supplied for use with the Aux7 Range Program Board. Prices quoted from the factory. See Operator's Manual for details. (Not available for services requiring type acceptance.)

TR7

ACCESSORIES

** Aux7 must be used with either Model 1546 RRM-7 Range Receive Module, or Model 1547 RTM-7 Range Transceiver Module. Use one module per 500 kHz range. Modules plug directly into Aux7.

Model 1336	Drake TR7 General Coverage Digital R/O Transceiver
Model 1338	Drake RV7 Remote VFO
Model 1502	Drake PS7 120/240V Ac Supply for continuous duty operation (25 amps)
Model 1570	Drake PS75 120/240V Ac supply for intermittent duty (15 amps continuous, 25 amps intermittent)
Model 1553	Drake SP75 Speech Processor
Model 1230	Drake LA7 Line Amplifier
Model 1533	Drake CS7 Coax Switch
Model 7077	Drake Desk Microphone
Model 1520	Drake P75 Phone Patch
Model 1536	Drake Aux7 Range Program Board **
Model 1531	Drake MS7 Matching Speaker
Model 1537	Drake NB7 Noise Blanker
Model 1529	Drake FA7 Fan
Model 7021	Drake SL-300 Cw Filter, 300 Hz
Model 7022	Drake SL-500 Cw Filter, 500 Hz
Model 7023	Drake SL-1800 Ssb/RTTY Filter, 1.8 kHz
Model 7024	Drake SL-6000 A-m Filter, 6.0 kHz
Model 1335	Drake MMK-7 Mobile Mounting Kit
Model 7037	Drake TR7 Service Kit/Extender Board Set
Model 385-0004	Drake TR7 Service/Schematic Book

TR7 SPECIFICATIONS

GENERAL

Receive

Without Aux7	1.5 to 30 MHz, continuous, no gaps.
With Aux7	Same, plus 0 to 1.5 MHz at reduced performance.

Transmit

Without Aux7	1.8-2.0, 3.5-4.0, 7.0-7.5, 14.0-14.5, 21.0-21.5, 28.0-30.0 MHz.
With Aux7*	Above ranges, plus any eight 500 kHz segments from 1.8 to 30 MHz.

Modes of Operation

Usb, Lsb, Cw, RTTY, A-m equiv. (A-3H).

Frequency Stability

Less than 1 kHz first hour. Less than 150 Hz per hour after 1 hour warm up. Less than 100 Hz for $\pm 10\%$ line voltage change.

Frequency Readout Accuracy

Analog	Better than ± 1 kHz when calibrated at the nearest marker point.
Digital	15 ppm \pm 100 Hz.

External Counter Mode

Maximum Input Freq.	150 MHz.
Input Level Range	50 mV to 2 V, rms.

Power Supply Requirements

11-16 V-dc (13.6 V-dc nominal), 3A receive, 25A transmit.

Dimensions

Depth	12.5 in. (31.75 cm), excluding knobs and connectors.
Width	13.6 in. (34.6 cm).
Height	4.6 in. (11.6 cm) excluding feet.
Weight	17.1 lb. (7.75 kg).

RECEIVER

Sensitivity

Ssb, Cw	Less than $0.5 \mu\text{V}$ for 10 dB (S+N)/N.
A-m (30% Mod.)	Less than $2.0 \mu\text{V}$ for 10 dB (S+N)/N.

Selectivity

2.3 kHz at -6 dB and 4.4 kHz at -60 dB (1.8:1 shape factor).

Ultimate Selectivity

Greater than 100 dB.

Agc

Less than 4 dB output variation for 100 dB input signal change, referenced to agc threshold.

Intermodulation

Intercept Point, +20 dBm. Two-tone Dynamic Range, 99 dB (at spacings of 100 kHz and greater).

I-f Frequency

First i-f—48.05 MHz.
Second i-f—5.645 MHz.

Image and I-f Rejection

Greater than 80 dB.

Spurious Response

Greater than 60 dB down.

Internally Generated Spurious

Less than $1 \mu\text{V}$ equivalent, except $3 \mu\text{V}$ equivalent from 5 to 6 MHz (reduced specs on internal osc frequencies).

Audio Output

2.0 watts @ less than 10% THD (4 ohm load).

TRANSMITTER

Power Input (Nominal)

Ssb	250 watts PEP.
Cw	250 watts.
A-m equiv.	80 watts (carrier), plus upper sideband.

Load Impedance

50 ohms, nominal.

Spurious Output

Greater than 50 dB down.

Harmonic Output

Greater than 45 dB down.

Intermodulation Distortion

30 dB below PEP (24 dB below one of two tones).

Undesired Sideband Suppression

Greater than 60 dB @ 1 kHz.

Duty Cycle

Ssb, Cw	100%.
Tune, SSTV, RTTY, A-m	w/o 1529 FA7 Fan—33%, 5 min. transmit, max. with 1529 FA7 Fan—100%.

Wattmeter Accuracy

$\pm 5\%$ @ 100 watts (50 ohm load).

Carrier Suppression

Greater than 50 dB.

Microphone Input

High Impedance.

Specifications, availability and prices subject to change without notice or obligation.

R. L. DRAKE COMPANY



540 Richard St., Miamisburg, Ohio 45342, USA
Phone: (513) 866-2421 • Telex: 288-017



DRAKE 7-Line Family



A pacesetter since 1943, Drake led in 1963 with 9 MHz i-f transceiving, and now with 48 MHz i-f "Up Conversion" ... Drake brings you tomorrow's state of the art today.



Model 1240

R7

Synthesized General Coverage Receiver

Full general coverage reception, 0-30 MHz, with no gaps or range crystals required.

Continuous tuning all the way from vlf thru hf. Superb state-of-the-art performance on a-m, ssb, RTTY, and cw—and it transceives with Drake TR7.

- **100% solid state broadband design**, fully synthesized with a permeability tuned oscillator (PTO) for smooth, continuous tuning.
- **Covers the complete range 0 to 30 MHz** with no gaps in frequency coverage. Both digital and analog frequency readout.
- **Special front-end circuitry** employing the high level double balanced mixer and 48 MHz "up-converted" 1st i-f for superior general coverage, image rejection and strong signal handling performance.
- **Complete front-end bandpass filters** are included that operate from hf thru vlf. External vlf preselectors are not required.
- **10 dB pushbutton-controlled broadband preamp** can be activated on all ranges above 1.5 MHz. Low noise design.
- **Various optional selectivity filters** for cw, RTTY and a-m are switch-selected from the front panel. Ssb filter standard.
- **Special new low distortion "synchro-phase" a-m detector** provides superior international shortwave broadcast reception. This new technique permits 3 kHz a-m sideband response with the use of a 4 kHz filter for better interference rejection.
- **Tunable i-f notch filter** effectively reduces heterodyne interference from nearby stations.
- **The famous Drake full electronic passband tuning system** is employed, permitting the passband position to be adjusted for any selectivity filter. This is a great aid in interference rejection.
- **Three agc time constants** plus "Off" are switch-selected from the front panel.
- **Complete transceive/separate functions** when used with the Drake TR7 transceiver are included, along with separate R7 R.I.T. control.
- **Special multi-function antenna selector/50 ohm splitter** is switch-selected from the front panel, and provides simultaneous dual receive with the TR7. This makes possible the reception of two different frequencies at the same time. Main and alternate antennas and vhf/uhf converters may also be selected with this switching network.
- **The digital readout** of the R7 may be used as a 150 MHz counter, and is switched from the front panel. Access thru rear panel connector.
- **The built-in power supply** operates from 100, 120, 200, 240 V-ac, 50/60 Hz, or nominal 13.8 V-dc.
- **The R7 includes a built-in speaker**, or an external Drake MS7 speaker may be used.
- **Built-in 25 kHz calibrator** for calibration of analog dial.
- **Low level audio output** for tape recorder.
- **Up to eight crystal controlled fixed channels** can be selected. (With Drake Aux7 installed.)
- **Optional Drake NB7A Noise Blanker** available. Provides true impulse type noise blanking performance.

R7

Accessories available

Model 1531	Drake MS7 Speaker
Model 7021	Drake SL-300 Cw Filter, 300 Hz
Model 7022	Drake SL-500 Cw Filter, 500 Hz
Model 7023	Drake SL-1800 Ssb/RTTY Filter, 1800 Hz
Model 7024	Drake SL-6000 A-m Filter, 6.0 kHz
Model 7026	Drake SL-4000 A-m Filter. 4.0 kHz
Model 1532	Drake NB7A Noise Blanker
Model 1536	Drake Aux7 Range Program/Fixed-Frequency Board
Model 1548	Drake R7/TR7 Interface Cable Kit
Model 385-0005	Drake R7 Service/Schematic Book
Model 3506	Drake RP700 Receiver Protector
Model 1230	Drake LA7 Line Amplifier

R7 SPECIFICATIONS

Frequency Coverage, continuous tuning 0.01 to 30.0 MHz

Plus any eight additional 500 kHz segments between 0 and 30 MHz when programmed into Aux7 Board.

Crystal Controlled Fixed Frequencies: Up to eight crystal-controlled fixed frequencies within the 0-30 MHz range with Aux7 Accessory Board. Proper 500 kHz range for desired fixed frequency is also programmed into Aux7.

Frequency Stability: Less than 1 kHz first hour. Less than 150 Hz per hour after 1 hour warm up. Less than 100 Hz for $\pm 10\%$ line voltage change.

Digital Readout Accuracy: (DR-7 installed) 15 PPM ± 100 Hz

Analog Dial Accuracy: Better than ± 1 kHz when calibrated to nearest calibrator marker.

Modes of Operation: Ssb, cw, RTTY, SSTV, a-m.

Sensitivity (ssb): 1.8-30 MHz Less than $.20\mu\text{V}$ for 10dB (S+N)/N with preamp on (typically $.15\mu\text{V}$) (Noise floor typically -134 dBm) Less than $.50\mu\text{V}$ for 10 dB (S+N)/N without preamp (typically $.30\mu\text{V}$) (Noise floor typically -128dBm). .01-1.5MHz Less than $1.0\mu\text{V}$ for 10 dB (S+N)/N

Sensitivity (a-m): 1.8-30MHz Less than $1.2\mu\text{V}$ for 10dB (S+N)/N @ 30% modulation, preamp on. Less than $2.0\mu\text{V}$ for 10 dB (S+N)/N @ 30% modulation, preamp off. .01-1.5 MHz Less than $4.0\mu\text{V}$ for 10 dB (S+N)/N @ 30% modulation.

Selectivity (2.3 kHz filter supplied): 2.3 kHz at -6 dB, 4.4 kHz at -60 dB (1.8:1) shape factor. Optional 300 Hz, 500 Hz, 1800 Hz, 4 kHz, and 6 kHz filters are available as follows:

Accessory Crystal Filters

- SL-300 cw filter: 300 Hz @ 6 dB, 700 Hz @ 60 dB
- SL-500 cw, RTTY Filter: 500 Hz @ 6 dB, 1100 Hz @ 60 dB
- SL-1800 ssb/RTTY Filter: 1800 Hz @ 6 dB, 3600 Hz @ 60 dB
- SL-4000 a-m Filter: 4 kHz @ 6 dB, 8 kHz @ 60 dB
- SL-6000 a-m Filter: 6 kHz @ 6 dB, 12 kHz @ 60 dB

Ultimate Selectivity: Greater than 100 dB

Intermodulation:

Two-tone dynamic range: 99 dB *	1.8-30 MHz
Third order intercept point: +20 dBm	preamp off
Two-tone dynamic range: 95 dB *	1.8-30 MHz
Third order intercept point: +10 dBm	preamp on
Blocking: >145 dB above noise floor	

**(at tone spacings of 100 kHz and greater)*

I-f and Image Rejection: Greater than 80 dB (48.05 MHz 1st i-f) (5.645 MHz 2nd i-f) (50 kHz 3rd i-f)

Agc Performance; Less than 4 dB audio output variation for 100 dB input signal change above agc threshold. Agc threshold is typical $.8\mu\text{V}$ with preamp off and $.25\mu\text{V}$ with preamp on.

Attack time: 1 millisecond. Three selectable release times: Slow—2 seconds; Med—400 m sec; Fast—75 m sec. Also, "Off" position is provided.

Antenna Input Impedance: Nominal 50 ohms

Audio Output: 2.5 watts with less than 10% T.H.D. into nominal 4 ohm load.

Power Requirements: 100/120/200/240 V-ac $\pm 10\%$, 50/60 Hz, 60 watts or 11.0 to 16.0 V-dc (13.8 V-dc nominal), 3 amps

External Counter Mode (DR-7 installed): Readout: to 100 Hz. Accuracy: 15 PPM ± 100 Hz. Maximum input frequency: 150 MHz. Input level range: 50 mV to 2 V rms.

Dimensions/Weight:

Depth—13.0 in (33.0 cm) excluding knobs and connectors.
Width— 13.6 in (34.6 cm)
Height— 4.6 in (11.6 cm) excluding feet
Weight— 18.4 lbs (8.34 kg)

Specifications, availability and prices subject to change without notice or obligation.

R. L. DRAKE COMPANY



540 Richard St., Miamisburg, Ohio 45342, USA
Phone: (513) 866-2421 • Telex: 288-017

DRAKE 7-Line Family



A pacesetter since 1943, Drake led in 1963 with 9 MHz i-f transceiving, and now with 48 MHz i-f "Up Conversion"... Drake brings you tomorrow's state of the art today.



Model 1528
Drake L7
Continuous Duty
160-15* Meters
**2kW Linear
Amplifier**

Temperature-controlled design for "key-down" operation over a wide frequency range.

2 kW PEP, 1 kW cw, RTTY, SSTV operation—all modes full rated input, continuous duty cycle.

160-15* meter amateur band coverage, plus expanded ranges for any future hf band expansions or additions within FCC rules. These ranges also include increased coverage for MARS, embassy, government, or other such services.

The Drake L7 utilizes a pair of Eimac 3-500 Z triodes for rugged use, and lower replacement cost compared to equivalent ceramic types.

Accurate built-in rf wattmeter, with forward/reverse readings, is switch selected. Calibrated 300/3000 watt scales.

Temperature controlled two speed fan is a high volume low noise type and offers optimum cooling.

Adjustable exciter agc feedback circuitry permits drive power to be automatically controlled at proper levels to prevent peak clipping and cw overdrive. Front panel control.

By-pass switching is included for straight through, low power operation without having to turn off amplifier.

Bandpass tuned input circuitry for low distortion and 50 ohm input impedance.

Amplifier is comprised of two units—rf deck for desk top and separate power supply.

Operates from 120/240 V-ac, 50/60 Hz primary line voltage.

DRAKE L7 SPECIFICATIONS

- **Frequency Coverage***: Ham bands 160 through 15 meters*. Non-amateur frequencies between 6.5 and 21.5 MHz may be covered with some modification of the input circuit.
- **Plate Power Input**: 2000 watts PEP on ssb and a-m. 1000 watts dc on cw, RTTY, and SSTV.
- **Drive Power Requirements**: 100 watts PEP on ssb and 75 watts on cw, a-m, RTTY, and SSTV.
- **Input Impedance**: 50 ohms. (Bandpass tuned input)
- **Output Impedance**: Adjustable pi-network matches 50 ohm line with SWR not to exceed 2:1.
- **Intermodulation Distortion Products**: In excess of -33 dB.
- **Wattmeter Accuracy**: 300 watts forward and reflected, $\pm 5\%$ of reading + 3 watts). 3000 watts forward, $\pm 5\%$ of reading + 30 watts).
- **Power Requirements**: 240 volts 50-60 hertz 15 amperes, or 120 volts 50-60 hertz 30 amperes.
- **Tube Complement**: Two of 3-500Z or 8802/3-500Z or 3-400Z.
- **Dimensions: Amplifier** 13.69"W x 6.75"H x 14.25"D (34.8 x 17.1 x 36.2 cm). **Power Supply** 6.75"W x 7.88"H x 11"D (17 x 20 x 28 cm).
- **Weight: Amplifier** 27 lbs (12.25 kg), **Power Supply** 42.5 lbs (19.3 kg).

*Export model includes coverage of the 10-meter Ham Band.



Model 1539

Drake Matching Networks MN7 and MN2700

Models 1538 and 1539

- **Frequency Coverage**: 1.8 - 30 MHz
- **Antenna Choice**: Matches antennas fed with coax, balanced line (use optional B-1000 Balun), or random wire.
- **Antenna/By-Pass Switching**: Allows matching unit by-pass regardless of antenna in use, and selects various antennas.
- **Extra Harmonic Reduction**: Employs "pi-network" low pass filter type circuitry for maximum harmonic rejection.
- **Built-in Metering**: Accurate Rf Wattmeter and VSWR Reading, pushbutton controlled from front panel.
- **Input Impedance**: 50 ohms resistive.
- **Power Capability**: MN7—250 watts average continuous duty (0-300 W scale). MN2700—1000 watts average continuous duty (2000 watts PEP). (0-200 or 0-2000 W scale).
- **Dimensions**: MN7—13.1"W x 4.53"H x 8.5"D excluding knobs and connectors (33.26 x 11.5 x 21.6 cm). MN2700—13.1"W x 4.53"H x 13"D excluding knobs and connectors (33.26 x 11.5 x 33 cm).
- **Weight**: MN7—10 lbs (4.5 kg). MN2700—11 lbs (5 kg).

Drake MN7 and MN2700 Specifications

- **Frequency Coverage**: 1.8 to 30 MHz. Band Switch marked for 160, 80, 40, 20, 15, and 10 meter amateur bands; however, frequency coverage between amateur bands is possible by using the nearest band positions with a small reduction in matching capability.
- **Input Impedance**: 50 ohms (resistive).
- **Load Impedance**: 50 ohm coaxial with VSWR of 5:1 or less at any phase angle (3:1 on 10 meters). 75 ohm coaxial at a lower VSWR can be used.
- **Balanced Feedlines**: With the Drake B-1000 accessory balun, which mounts on rear panel, tunes feed point impedances of 40 to 1000 ohms, or 5:1 VSWR referenced to 200 ohms (3:1 on 10 meters).
- **Long-Wire Antennas**: Feed point impedances up to 5:1 VSWR referenced to 50 ohms. Also, 5:1 referenced to 200 ohms with the Drake B-1000 accessory balun (3:1 on 10 meters).
- **Meter**: Reads VSWR or forward power.
- **Wattmeter Accuracy**: $\pm 5\%$ of reading $\pm 1\%$ of full scale.
- **Insertion Loss**: 0.5 dB or less on each band after tuning.
- **Front Panel Controls**: Provide for the adjustment of resistive and reactive tuning, antenna switching, band switching, VSWR calibration, and selection of watts or VSWR calibration, and selection of watts or VSWR functions of the meter.
- **Rear Panel Connectors**: The rear panel has four type SO-239 connectors (one for input and 3 for outputs), three screw terminal connections (for long-wire and open-wire feeder systems), and a ground post.

Specifications, availability and prices subject to change without notice or obligation.

R. L. DRAKE COMPANY



540 Richard St., Miamisburg, Ohio 45342, USA
Phone: (513) 866-2421 • Telex: 288-017

DRAKE 7-Line Family



ACCESSORIES

A Model 7077 Dynamic Desk Microphone

- **Audio and level characteristics** custom designed to match the transmit audio requirements of the Drake TR7.
- **Features both VOX and PTT operation** without modification.
- **High Impedance** • Includes coil cord and plug wired for direct connection to the Drake TR7.
- **Style and color** provide a beautiful match to the Drake 7-line
- **Size** 4.3"W x 5.8"D x 9.3"H (10.9 x 14.7 x 23.6 cm).
- **Weight** 1 lb 7 oz (650 g).

Model 1553

C SP75 Speech Processor

Provides an increase in average power/readability of a single sideband voice signal during weak signal, high interference conditions. The SP75 is connected between the microphone and microphone input of the ssb transmitter, requiring no modification of existing transmitter or transceiver. A front panel switch allows the processor to be switched in or bypassed. Two additional inputs, such as a tape player or phone patch, may be front panel selected.

Rf envelope clipping adjustable between zero and twenty decibels. LED indicates proper audio input level.

Muting circuitry reduces gain during speech pauses, allowing VOX operation with the processor on.

SPECIFICATIONS • **Processing Type:** Preclipping audio compression followed by rf envelope clipping at the processor intermediate frequency. • **Rf Clipping Range:** Adjustable 0 to 20 dB from front panel control. • **Input Level (Microphone Input):** 3.5 mV minimum for full processing. Gain adjustable to accommodate up to 300 mV maximum. • **Input Level (Tape and Patch Inputs):** 15 mV minimum for full processing. 30 mV maximum. • **Input Impedance (Microphone):** 1 megohm. • **Input Impedance (Tape and Patch):** 50 kilohm. • **Output Level w/Processing:** 0-50 mV adjustable into 50 kilohm load. • **Output Impedance:** 50 kilohm. • **Muting (Microphone Input Only):** 10 to 20 dB attenuation during speech pauses. • **Frequency Response:** 400-6000 Hz @ 6 dB. • **Distortion:** Less than 5% T.H.D. @ 1kHz, 20 dB clipping. • **Power:** 11-16 V-dc @ 95 mA. • **Size:** 7"L x 6 1/4"W x 2 1/4"H (17.3 x 15.9 x 5.4 cm). • **Weight:** 1.4 lbs. (.63 kg).

Model 1520

D P75 Phone Patch

Hybrid Phone Patch for use with 7-line or other receiver/transmitter combination. • In/Out Switching • Adjustable TX and RX level controls.

Model 1535

E CS7 Coax Switch

- Switches up to five coax-fed antennas via one main feed line.
- Allows selection of up to five radios at other end of main feed line.
- Minimizes amount of coax needed for multi-antenna installation.
- Grounds unused inputs (both local and remote).

DRAKE CS7 SPECIFICATIONS • **Maximum Input Power:** 2000 watts PEP • **Frequency Range:** Up to 30 MHz, insertion of Switch changes VSWR no more than 1.05:1. From 30 MHz to 150 MHz, insertion changes VSWR no more than 1.5:1 (both switches). • **Operating Temperature Range:** -40°F. to 150°F. • **Supply Voltage:** 120 V-ac or 240 V-ac selectable, 50/60 Hz, 50 watts. • **Dimensions & Weight:** Console—5.25"H x 6.81"W, 7.06" cabinet depth (13.3 x 17.3 x 17.9 cm); 4.33 lbs (1.96 kg); **Remote Antenna Switch**—7.13"H x 5.88"W x 4.39"D (18.1 x 15.0 x 11.1 cm), 8.19" (20.8 cm) center to center mounting; 5 lbs (2.27 kg).

Model 1531

B MS7 Matching Speaker

- **Size:** 7.5"D x 6.9"W x 4.6"H excluding feet (19 x 17.5 x 11.6 cm).
- **Weight:** 2.5 lbs (1.13 kg).

"Dry" Dummy Loads —no oil required

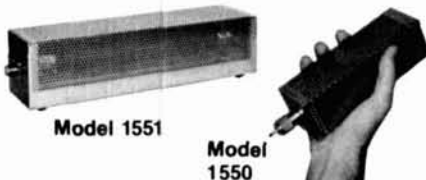

Model 1551 Drake DL-1000

- **1000 watts** for 30 seconds, with derating curve to 5 minutes. Accepts Drake FA7 cooling fan for extended high power operation.
- **VSWR of 1.5:1 max.** 0-30 MHz • **SO-239 coax connector**
- **Rubber feet** for desk or bench use • **Size** 14" x 3.6" (35.6 x 9.1 cm). • **Weight:** 2 lbs (910 g).

Model 1550 Drake DL-300

- **300 watts** for 30 seconds, with derating curve to 5 minutes. • **Built-in PL-259** coax connector for direct connection to rear of transceiver or transmitter—no jumper coax necessary. • **VSWR of 1.1:1 max.** 0-30 MHz 1.5 max 30-160 MHz • **Ideal as bench test device** for amateur or commercial hf and vhf gear.
- **Small size** fits conveniently in any field service tool box. 6.7" x 2.08" (17.0 x 5.3 cm). • **Weight:** 11 oz (310 g).



WH7 Directional Rf Wattmeter

Model 1514

- Directional, in-line wattmeter.
- Removable coupler provides remote metering.
- Three calibrated scales (0-20, 0-200, and 0-2000 watts).
- Fourth scale provides direct reading VSWR.

SPECIFICATIONS: • **Frequency Coverage:** 1.8-30 MHz. • **Line Impedance:** 50 ohm resistive. • **Power Capability:** 2000 W continuous. • **Jacks, Removable Coupler:** Two SO-239 input and output connectors. • **Semiconductors:** Two power meter rectifiers. • **Accuracy:** ±(5% of reading + 1% of full scale). • **VSWR Insertion:** Insertion of wattmeter in line changes VSWR no more than 1.05:1. • **Shipping Weight:** 3 lbs (1.4 kg). • **Dimensions:** 5.3"H x 6.9"W x 7.5"D (13.5 x 17.5 x 19 cm).

Model 1230

LA7 Line Amplifier

Line output, 1 mW nominal into 600 ohm balanced, adjustable by internal pre-set level control.

TV Interference Filters

High Pass Filters for TV Sets

More than 40 dB attenuation at 52 MHz and lower. Protect the TV set from amateur transmitters 6-160 meters.



Model No. 1603 Drake TV-300-HP

For 300 ohm twin lead. New terminals for easy installation.

Model No. 1610 Drake TV-75-HP

For 75 ohm TV coaxial cable; TV type "F" connectors installed.

Low Pass Filters for Transmitters



Four pi sections for sharp cut off above the hf amateur bands and to attenuate transmitter harmonics falling in any TV channel and 1m band. 52 ohm. SO-239 connectors built in.

Model No. 1608 Drake TV-3300-LP

1000 watts max. below 30 MHz. Attenuation better than 80 dB above 41 MHz. Helps TV i-f interference, as well as harmonic interference.

Model No. 1605 Drake TV-42-LP

A four section filter designed with 43.2 MHz cut-off and extremely high attenuation in all TV channels for transmitters operating at 30 MHz and lower. Rated 100 watts input.

Specifications, availability and prices subject to change without notice or obligation.

R. L. DRAKE COMPANY



540 Richard St., Miamisburg, Ohio 45342, USA Phone: (513) 866-2421 • Telex: 288-017

More Details? CHECK—OFF Page 94

november 1980 **hp** 67

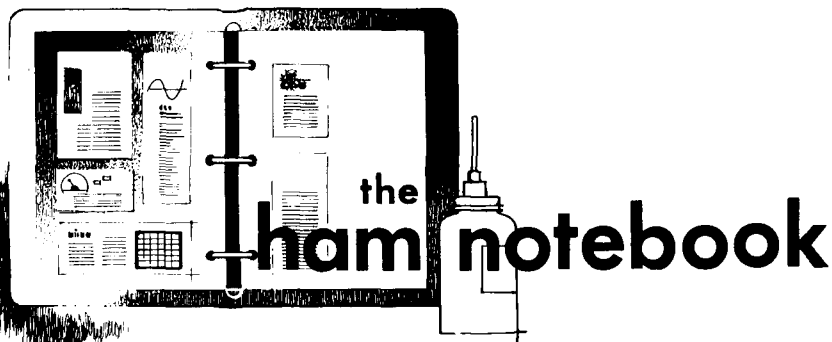

the T coupler

Here's a handy little gadget for your shack or shop that I've found to be as useful as the zip top on a Bud.

If you've ever had a need for a convenient transmitter-to-counter coupler, low power dummy load, matching network for a signal generator, or a little device to help measure repeater desense, this might be just what the doctor ordered. Basically, it's a 50-ohm, 2-watt dummy load and capacitance coupler made from three standard uhf connectors: a barrel (PL-258), a tee (M-358), and a plug (PL-259).

Construction is simple. Insert a 50-ohm, 2-watt resistor into the back of a PL-259 (fig. 1). Solder and trim the pin end of the connector. Trim the resistor lead at the back end of the connector and fill with solder to prevent any rf leakage. This will serve as your conventional 2-watt dummy load. Not too tricky so far.

Now, modify the T connector as follows. Unscrew the pin from the center section T and replace it with a flat-head screw. Over the head of the screw, place two or three pieces of insulation mica or plastic. Insert another flat-head screw into one end of the barrel connector. Now screw all three connectors together and check continuity to ensure proper insulation.

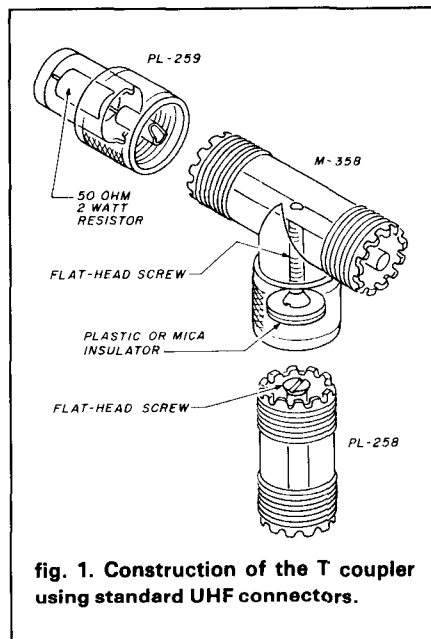

fig. 1. Construction of the T coupler using standard UHF connectors.

When tuning a low-power transmitter, a counter can now be coupled through the barrel. For higher-power transmitters, replace the 2-watt dummy load with a larger one.

With a receiver coupled to the 50-ohm match, a signal generator can be coupled by means of the barrel connector.

To check repeater desense, connect the duplexer output to a suitable dummy load through the T and connect a calibrated generator through the barrel connector. Measure the

signal difference with the transmitter on and at idle.

Now that you've probably thought of at least 27 other uses for this little gem, there's no excuse for not adding it to your test bench.

John LaMartina, K3NXU

improved ground-mounted vertical for the lower bands

When using ground-mounted verticals a good ground system is essential for best results. In the case of a 1/4-wave or shorter vertical, the largest current in the ground system is near the base. Many radials will result in a small amount of power loss. However, it should be possible to improve on the average ground system by moving the high current portion of the ground into a metal conductor. A coaxial vertical antenna is the basis for this idea.

The upper 1/4 wave could be shortened by top loading. The lower 1/4-wave sleeve also could be cut to a more convenient length, with the feed line passing through the sleeve, as usual. The ground radials would be connected to the bottom of the sleeve at ground level.

Increasing the height above ground of the high-current portion, and allowing current to flow into a low-loss conductor out of the ground, should result in some degree of improvement. Of course, a full-size coaxial vertical would be nice — it wouldn't need any ground radials at all. Quite impressive, too, at 260 feet (79 meters) it would direct passing hams to your location from miles away.

E.R. Lamprecht, W5NPD

modification of Ham-M rotator control box

Early models of the popular Ham-M rotator have one very undesirable characteristic. When power is removed from the rotator motor, power is simultaneously removed from the

brake solenoid, causing the brake to slam into the rotator housing. This brings the moving antenna to an abrupt halt, thereby applying severe torsional strain to mast, rotator and tower.

I redesigned the switch in the control unit to change the make-break contacts so the antennas would come to a halt before the brake was applied. I had no way to manufacture a substitute switch, so I sent a drawing of the switch to the manufacturer and suggested the improvement. They said they were not interested! I had no intention of installing a torsion bar (per the manual) on my tower when there surely must be a better way.

Simple wiring changes in the control box of Series-3 units will provide independent brake control with no additional parts or switches and no drilling. My Ham-M is a Series 1, in which I modified the control unit to a Series 3 configuration per the simple instructions in the owner's manual, which came with the unit. Therefore, Series 1 and Series 2 units should be modified to Series 3 before the changes are made.

When the following changes have been made, moving the control lever slightly to right or left will cause the meter to indicate antenna position and will simultaneously release the brake. Moving the lever full right or left will start rotation. When the antenna has reached the desired heading, moving the lever back to first position will allow the antenna to come to a gentle stop. Returning the lever to center position then applies the brake.

I put a piece of masking tape just above the screw terminals on the back of the control box and marked them 1 Blk, 2 Red, 3 Blu, and so on. It is also a good idea to mark out the Series 1 on the control box back and change it to Series 3 for reference, if, indeed, you're modifying one of the earlier models.

One final note: In modifying my

unit, I used parts of three schematics to come up with the desired result. I decided to write out the steps required and work from that, rather than pick off each step from a drawing. It worked beautifully for me and I'm sure it will for you.

mod steps

Viewing the control box switch from the top, contact 1 is the first contact on lower left; other contacts progress clockwise. Proceed as follows.

1. Remove eight wires from rear terminal strip. They will be returned to their original position when wiring is completed. Remove four rubber mounting feet. Lift off plastic cabinet. Remove four screws that hold meter assembly to base plate. Move meter assembly outward to provide access to control switch. It may be necessary to remove the power-transformer mounting screws to provide access to the inside of rear terminal strip. In the following wiring changes, when a connection is made, it should be soldered unless another wire is to be connected to that point later, in which case the instructions will say "do not solder."
2. Disconnect wire from SW contact 1. Leave it connected to 5 on rear terminal strip.
3. Remove jumper that is connected between SW contacts 4 and 8.
4. Remove from SW contact 4 the wire that goes to the primary of the *instrument* transformer.
5. Remove wire that connects SW contact 2 to 2 on rear terminal strip.
6. Remove wire from SW contact 3. Leave other end connected to 6 on rear terminal strip.
7. Reroute this wire from terminal 6 and solder to SW contact 8.
8. Remove the bottom wire from the primary winding of the *power* transformer.

9. Connect the wire just removed from the power transformer to 2 on the rear terminal strip. This now connects SW contact 6 to rear terminal strip 2.

10. Remove the wire from SW contact 4. (This is one lead of the primary of the *instrument* transformer.)

11. Connect the wire just removed to SW contact 2. Do not solder.

12. Connect a wire from the bottom terminal on the *power* transformer to SW contact 2. Solder two.

13. Install a jumper wire between SW contacts 1 and 3. Do not solder 3.

14. Remove wire that connects SW contact 7 to 3-amp fuse holder on instrument side of fuse.

15. Connect a wire from 3-amp fuse holder on instrument side of fuse to SW contact 3. Solder two.

16. Connect the wire attached to 5 on the rear terminal strip to SW contact 4. In this modification switch contacts 5 and 7 are not used.

This completes the wiring. It might be a good idea to check over the instructions before starting the modification, once the unit is removed from the cabinet. In this way it will become apparent as to just what's happening and why the brake operation will be independent of rotation.

After attaching the eight wires to the rear terminal strip, check out, with 120-Vac connected, should read approximately 30 Vac across terminals 1 and 2 when the switch is operated in either direction. A reading of 31 Vdc across terminals 3 and 7 with the switch operated is normal.

I modified my rotor control about three years ago and it has certainly been a source of pleasure to know that my tower, beams, and rotator are no longer subjected to the severe (and totally unnecessary) torsional forces.

**William G. Blankenship, Jr.,
K4DLA/W1RDR**

fact: ARMCHAIR COPY begins here!

The NEW Model 444D For: High/Low Impedance SSB/FM

The Model 444D incorporates all the tried-and-proven features that made Shure's Model 444 the recognized "standard" fixed-station microphone among serious amateurs. The 444D retains the Shure-designed, super-rugged CONTROLLED MAGNETIC® microphone element that lets you come across with "armchair copy"! Its unmatched performance characteristics include a tailored response for maximum voice intelligibility, PLUS...

DUAL IMPEDANCE—(150 ohms) Low & High. Impedance selector switch located on bottom of base.

FREE NAMEPLATE IMPRINTED WITH YOUR CALL LETTERS—Personalized nameplate with your station call letters.

ALL-NEW WIRING GUIDE—Provides user instructions for wiring the microphone to major manufacturers' ham equipment.

IMPROVED CONTROL BAR—Shure Million-Cycle push-to-talk (PTT) improved fingertip action actuates microphone and an external relay or control circuit.

VOX/NORMAL SWITCH—Defeats PTT switch, for VOX equipment requiring continuously "on" microphone. Located conveniently on bottom of base.

PROFESSIONAL BLACK FINISH—Sturdy, high impact ARMO-DUR® base and microphone case is metalized for RF shielding. It is comfortable to the touch in any temperature or humidity, and will not rust or deteriorate.

CONVENIENT INSTALLATION
—The coiled cable leads and push-to-talk switch are arranged to permit immediate hookup to transmitters with either isolated or grounded switching.

FREE! Personalized call letter nameplate

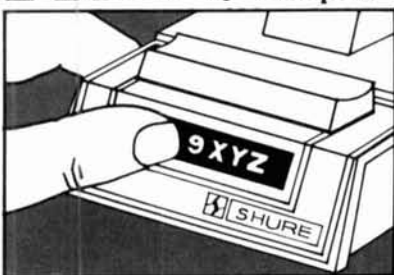

Intelligibility &
Reliability

®  **SHURE** ®

Shure Brothers Inc., 222 Hartrey Ave., Evanston, IL 60204
In Canada: A. C. Simmonds & Sons Limited

Outside the U.S. or Canada, write to Shure Brothers Inc., Attn: Dept J6 for information on your local distributor.
Manufacturers of high fidelity components, microphones, sound systems and related circuitry.

Save on Scanners! NEW Rebates!

Communications Electronics™, the world's largest distributor of radio scanners, celebrates Christmas early with big savings on Bearcat synthesized scanners. Electra Company, the manufacturers of Bearcat brand scanners is offering consumer rebates on their fantastic line of crystalless scanners purchased between September 15 and November 15, 1980.

We give you excellent service because CE distributes more scanners worldwide than anyone else. Our warehouse facilities are equipped to process thousands of scanner orders every week. We also export scanners to over 300 countries and military installations. Most items are in stock for quick shipment. Do your Christmas scanner shopping early and order today from CE!

Bearcat® 300

The Ultimate Synthesized Scanner!

List price \$519.95/CE price \$329.00/\$20.00 rebate
Your final cost is a low \$309.00

4-Band, 50 Channel • Service Search • No-crystal scanner • AM Aircraft and Public Service bands. • Priority Channel • AC/DC Bands: 32-50, 118-136 AM, 144-174, 421-512 MHz. The new Bearcat 300 is the most advanced automatic scanning radio that has ever been offered to the public. The Bearcat 300 uses a bright green fluorescent digital display, so it's ideal for mobile applications. The Bearcat 300 now has these added features: Service Search, Display Intensity Control, Hold Search and Resume Search keys, Separate Band keys to permit lock-in/lock-out of any band for more efficient service search.

Bearcat® 250

List price \$419.95/CE price \$259.00/\$20.00 rebate
Your final cost is a low \$239.00

50 Channels • Crystalless • Searches Stores • Recalls • Digital clock • AC/DC Priority Channel • 3-Band • Count Feature. Frequency range: 32-50, 146-174, 420-512 MHz. The Bearcat 250 performs any scanning function you could possibly want. With push button ease you can program up to 50 channels for automatic monitoring. Overseas customers should order the Bearcat 250FB at \$349.00 each. This model is like a Bearcat 250, but designed for international operation with 220 VAC/12 V DC power supply and 66-88 MHz low band coverage instead of 32-50 MHz.

Bearcat® 220

List price \$419.95/CE price \$259.00/\$20.00 rebate
Your final cost is a low \$239.00

Aircraft and public service monitor. Frequency range: 32-50, 118-136 AM, 144-174, 420-512 MHz. The Bearcat 220 is one scanner which can monitor all public service bands plus the exciting AM aircraft band channels. Up to twenty frequencies may be scanned at the same time. Overseas customers should order the Bearcat 220FB at \$349.00 each. This model is like a Bearcat 220, but designed for international operation with 220 V AC/12 V DC power supply and 66-88 MHz low band coverage instead of 32-50 MHz.

NEW! Bearcat® 210XL

List price \$319.95/CE price \$209.00/\$20.00 rebate
Your final cost is a low \$189.00

18 Channels • 3 Bands • Crystalless • AC/DC Frequency range: 32-50, 144-174, 421-512 MHz. The Bearcat 210XL scanning radio is the second generation scanner that replaces the popular Bearcat 210 and 211. It has almost twice the scanning capacity of the Bearcat 210 with 18 channels plus dual scanning speeds and a bright green fluorescent display.



NEW! 50-Channel Bearcat 300

More Details? CHECK—OFF Page 94

FREE Bearcat® Rebate Offer

Get a coupon good for a \$20 rebate when you purchase a Bearcat 300, 250, 220 or 210XL. \$10 rebate on models 211, 210 and 160. To get your rebate, mail this coupon with your original dated sales receipt and the Bearcat model number from the carton to Electra. You'll receive your rebate in four to six weeks. Offer valid only on purchases made between September 15, 1980 and November 15, 1980. All requests must be postmarked by November 29, 1980. Limit of one rebate per household. Coupon must accompany all rebate requests and may not be reproduced. Offer good only in the U.S.A. Void where taxed or prohibited by law. Resellers, companies, clubs and organizations—both profit and non-profit—are not eligible for rebates. Employees of Electra Company, their advertising agencies, distributors and retailers of Bearcat Scanners are also not eligible for rebates. Please be sure to send in the correct amount for your scanner. Pay the listed CE price in this ad. Do not deduct the rebate amount since your rebate will be sent directly to you from Electra. Orders received with insufficient payments will not be processed and will be returned.

NEW! Bearcat® 160

List price \$279.95/CE price \$189.00/\$10.00 rebate
Your final cost is a low \$179.00

16 Channels • 3 Bands • AC only • Priority Dual Scan Speeds • Direct Channel Access Frequency range: 32-40, 144-174, 440-512 MHz. The Bearcat 160 presents a new dimension in scanning form and function. The keyboard is smooth. No buttons to punch. No knobs to turn. Instead, finger-tip pads provide control of all scanning operations, including On/Off, Volume and Squelch. Green easy to read fluorescent display.

NEW! Bearcat® 5/800 MHz

The world's first 800 MHz. scanner!

This is a new model. Shipments will begin in November, 1980.

List price \$179.95/CE price \$129.00

8 Crystal Channels • 4 Bands • AC only Frequency range: 33-50, 144-174, 440-512, 806-870 MHz. The Bearcat 5/800 MHz is the only scanner on the market today that offers coverage of the 800 MHz. public service band and the other public service bands. Individual channel lockout. Scan Delay. Manual Scan.

Bearcat® 5

List price \$129.95/CE price \$94.00

8 Crystal Channels • 3 Bands • AC only Frequency range: 33-50, 146-174, 450-508 MHz. The Bearcat 5 is a value-packed crystal scanner built for the scanning professional — at a price the first-time buyer can afford. Individual lockout switches.

Bearcat® Four-Six Thin Scan™

List price \$179.95/CE price \$114.00

Frequency range: 33-47, 152-164, 450-508 MHz. The incredible, new Bearcat Four-Six Thin Scan™ is like having an information center in your pocket. This three band, 6 channel crystal controlled scanner has patented Track Tuning on UHF. Scan Delay and Channel Lockout. Measures 2 3/4 x 6 1/4 x 1 1/2". Includes rubber ducky antenna. Order crystals for each channel. Made in Japan.

NEW! Fanon Slimline 6-HLU

List price \$169.95/CE price \$109.00

Low cost 6-channel, 3-band scanner! The new Fanon Slimline 6-HLU gives you six channels of crystal controlled excitement. Unique Automatic Peak Tuning Circuit adjusts the receiver front end for maximum sensitivity across the entire UHF band. Individual channel lockout switches. Frequency range 30-50, 146-175 and 450-512 MHz. Size 2 3/4 x 6 1/4 x 1 1/2". Includes rubber ducky antenna. Order crystal certificates for each channel. Made in Japan.

NEW! Fanon Slimline 6-HL

List price \$149.95/CE price \$99.00

6-Channel performance at 4-channel cost! Frequency range: 30-50, 146-175 MHz. If you don't need the UHF band, get this model and save money. Same high performance and features as the model HLU without the UHF band. Order crystal certificates for each channel. Made in Japan.

FANON SCANNER ACCESSORIES

CHB-6 AC Adapter/Battery Charger \$15.00
CAT-6 Carrying case for Fanon w/Belt Clip \$15.00
AUC-3 Auto lighter adaptor/Battery Charger \$15.00

OTHER SCANNER ACCESSORIES

SP50 AC Adapter \$12.00
SP51 Battery Charger \$12.00
SP58 Carrying Case for Bearcat 4-6 ThinScan™ \$15.00
FB-E Frequency Directory for Eastern U.S.A. \$15.00
FB-W Frequency Directory for Western U.S.A. \$15.00
FFD Federal Frequency Directory for U.S.A. \$18.00
B-4 1.2V AAA Ni-Cad's for ThinScan™ and Fanon \$15.00
A-135-cd Crystal certificate \$4.00
Add \$3.00 shipping for all accessories ordered at the same time.

INCREASED PERFORMANCE ANTENNAS

If you want the utmost in performance from your scanner, it is essential that you use an external antenna. We have six base and mobile antennas specifically designed for receiving all bands. Order #A60 is a magnet mount mobile antenna. Order #A61 is a gutter clip mobile antenna. Order #A62 is a trunk-lip mobile antenna. Order #A63 is a 3/8 inch hole mount. Order #A64 is a 3/8 inch snap-in mount, and #A70 is an all band base station antenna. All antennas are \$30.00 and \$3.00 for UPS shipping in the continental United States.

TEST ANY SCANNER

Test any scanner purchased from Communications Electronics™ for 31 days before you decide to keep it. If for any reason you are not completely satisfied, return it in original condition with all parts in 31 days, for a prompt refund (less shipping/handling charges and rebate credits).

NEW! Regency® M400

List price \$379.95/CE price \$259.00

30 Channel • Synthesized • Service Search Digital clock • Digital timer • M100 styling Search/Store • Priority Channel • AC/DC Frequency range: 30-50, 144-174, 440-512 MHz. The new Regency M400 is a compact programmable FM monitor receiver for use at home or on the road.

OTHER REGENCY® SCANNERS

Touch K100 \$199.00
Touch M100 \$199.00

NEW! Telephone Products

Electra's cordless Freedom Phone does everything an ordinary phone does and more. Because it is cordless, you can take it anywhere, inside or outside—on the patio, by the pool, in the garage, in the workshop...even next door at the neighbor's.

Model FF-500 has pushbutton dialing. Rechargeable ni-cad batteries included. Battery low light. Secure feature. Telescopic antenna. Your cost is \$179.00. Model FF-1500 has the same features as the FF-500 but also includes a charger/cradle that allows the phone's handset to be recharged away from the base station. Your cost for this cordless phone is \$199.00. The model FF-3000 has all the standard features (except charger/cradle) plus interchangeable telescopic and rubber ducky antenna. Redial feature. Belt clip. Carrying case. Greater range. Your cost is \$229.00.

World Scanner Association™

The WORLD SCANNER ASSOCIATION is sponsored as a public service by Communications Electronics.™ When you join, you'll receive a one-year membership and our quarterly newsletter with scanner news and features. You'll also get a wallet I.D. card, an Official WSA Membership Certificate, and more. FREE classified ads for members so you can contact other scanner owners when you want to sell or buy a scanner. FREE membership in the WSA Buyer's Co-op. Your Co-op membership will allow you to get special discounts on scanners and scanner related products. Since the WSA Buyer's Co-op gives you group purchasing power, you can easily pay for your membership dues the first time you make a Co-op purchase. To join, send \$12.00 (\$20.00 outside U.S.A.) for your membership materials.

BUY WITH CONFIDENCE

To get the fastest delivery from CE of any scanner, send or phone your order directly to our Scanner Distribution Center.™ Be sure to calculate your price using the CE prices in this ad. Michigan residents please add 4% sales tax. Written purchase orders are accepted from approved government agencies and most well rated firms at a 10% surcharge for net 30 billing. All sales are subject to availability. All sales on accessories are final. Prices, terms and specifications are subject to change without notice. Out of stock items will be placed on backorder automatically unless CE is instructed differently. Most products that we sell have a manufacturer's warranty. Free copies of warranties on these products are available prior to purchase by writing to CE. International orders are invited with a \$20.00 surcharge for special handling in addition to shipping charges. All shipments are F.O.B. Ann Arbor, Michigan. No COD's please. Non-certified and foreign checks require five weeks bank clearance.

Mail orders to: Communications Electronics,™ Box 1002, Ann Arbor, Michigan 48106 U.S.A. Add \$6.00 per scanner or phone product for U.P.S. ground shipping, or \$12.00 for faster U.P.S. air shipping to some locations. If you have a Master Charge or Visa card, you may call anytime and place a credit card order. Order toll free in the U.S.A. 800-521-4414. If you are outside the U.S. or in Michigan, dial 313-994-4444. Dealer inquiries invited. All order lines at Communications Electronics™ are staffed 24 hours.

WSA,™ Scanner Distribution Center™ and CE logos are trademarks of Communications Electronics.™

† Bearcat and Freedom Phone are federally registered trademarks of Electra Company, a Division of Masco Corporation of Indiana.

‡ Regency is a federally registered trademark of Regency Electronics Inc.

Copyright © 1980 Communications Electronics™



COMMUNICATIONS ELECTRONICS™

854 Phoenix □ Box 1002 □ Ann Arbor, Michigan 48106 U.S.A.
Call TOLL-FREE (800) 521-4414 or outside U.S.A. (313) 994-4444

We're first with the best.™

november 1980 **71**

HITACHI**KEITHLEY****VIZ** formerly **rci****TRIPLETT****PHILIPS****HICKOK****FLUKE**®**New Portable Digital Capacitance Meter****BK PRECISION**

Call For Our Price

MODEL 820

- Measures capacitance from 0.1 pF to 1 Farad
- Resolves to 0.1 pF
- 10 ranges for accuracy and resolution
- 4 digit easy-to-read LED display
- 0.5% accuracy
- Special lead insertion jacks or banana jacks
- Fuse protected
- Uses either rechargeable or disposable batteries
- Overrange indication

FLUKE DIGITAL MULTIMETERS**Model 8022A:
The Troubleshooter****\$139**

- **Six functions**
- 3½-digit resolution
- dc voltage
- ac voltage
- dc current
- ac current
- resistance
- diode test
- 0.25% basic dc accuracy
- LCD display
- Overload protection

**Model 8020A:
The Analyst****\$179****Model 8024A:
The Investigator****\$219****NEW****• Seven functions**

- dc voltage
- ac voltage
- dc current
- ac current
- resistance
- diode test
- conductance (1/R)
- 3½-digit resolution
- 0.1% basic dc accuracy
- LCD display
- Overload protection
- **Free case**
- Two year parts and labor warranty

• Nine functions

- dc voltage
- ac voltage
- dc current
- ac current
- resistance
- diode test
- conductance (1/R)
- logic level and continuity detect
- temperature (K-type thermocouple)
- Peak hold on voltage and current functions
- Selectable audible indicator for continuity or level detection
- 3½-digit resolution
- 0.1% basic dc accuracy
- LCD display
- Overload protection

**DATA PRECISION
Model 938****0.1%, 3½-Digit, LCD DIGITAL
CAPACITANCE
METER****\$179**

- **WIDE RANGING** — from 199.9 pF full scale (0.1 pF resolution) up to 1999 µF full scale, in eight ranges...virtually every capacitance you'll ever need to measure.
- **FAST AND EASY TO USE** — Direct reading, pushbutton ranges. Just plug in and read.
- **EXCEPTIONALLY ACCURATE** — provides ±0.1% basic accuracy.
- **TOUGH AND COMPACT** — Built to take rough usage without loss of calibration accuracy. Fits and goes anywhere, takes very little bench space, always handy for quick capacitance checkout, matching, calibration, and tracking.
- **PORTABLE** — Palm-sized, light-weight, operates up to approximately 200 hours on a single 9V alkaline battery.
- **EASY READING** — big, clear, high-contrast 3½-digit LCD display, a full 0.5" high, readable anywhere.
- **VALUE PACKED** — Outstanding measurement capability and dependability. Outperforms DC time-constant meters, and even bridges costing 2 to 5 times as much.
- **RELIABLE** — warranted for 2 full years.

HICKOK**LX304 DIGITAL MULTIMETER****FAST, EASY,
ONE HAND
OPERATION****NEW****AVAILABLE NOW
\$89⁹⁵****New Low Distortion Function Generator****BK PRECISION**

Call For Our Price

MODEL 3010

- Generates sine, square and triangle waveforms
- Variable amplitude and fixed TTL square-wave outputs
- 0.1 Hz to 1MHz in six ranges
- Push button range and function selection
- Typical sine wave distortion under 0.5% from 0.1Hz to 100kHz
- Variable DC offset for engineering applications
- VCO external input for sweep-frequency tests

New Sweep/Function Generator**BK PRECISION**

Call For Our Price

MODEL 3020

- Four instruments in one package—sweep generator, function generator, pulse generator, tone-burst generator
- Covers 0.02Hz-2MHz
- 1000:1 tuning range
- Low-distortion high-accuracy outputs
- Three-step attenuator plus vernier control
- Internal linear and log sweeps
- Tone-burst output is front-panel or externally programmable

Simpson

BK PRECISION

LEADER

DORIC

NLS Non-Linear Systems

WESTON

DATA PRECISION

PORTABLE OSCILLOSCOPES
BATTERY OPERATED

MS-15



Single Trace 15MHz
Reg. price \$349.
\$299⁹⁵

MS-215



Dual Trace 15 MHz
Reg. price \$465.
\$399⁹⁵

MS-230



Dual Trace 30MHz
Regular price \$598.
\$499⁹⁵

THESE 1980 B&K OSCILLOSCOPES
ARE IN STOCK AND AVAILABLE
FOR IMMEDIATE DELIVERY



BK PRECISION

- 1479A Dual-Trace 30 MHz
- 1477 Dual-Trace 15 MHz
- 1432 Dual-Trace 15 MHz Portable
- 1476 Dual-Trace 10 MHz
- 1466 Single-Trace 10 MHz
- 1405 Single-Trace 5 MHz

CALL FOR OUR
EARLY BIRD SPECIAL LOW PRICE

KEITHLEY

Model 169
BENCH/PORTABLE DMM

- 3 1/2 Digit liquid crystal display
- 0.25% basic accuracy
- 26 Ranges

\$15900

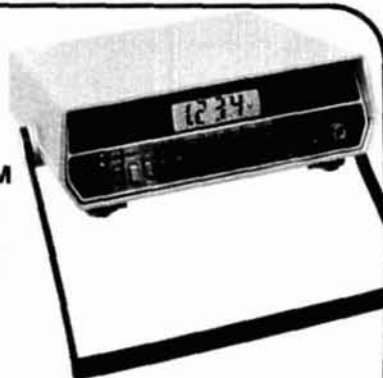

WESTON

The Roadrunner
Model 6100

- 5 Range audible signaling function
- 0.5" LCD display
- 6 Functions
- 29 Ranges

\$139.00



BEEP!
BEEP!

80MHz Counter with Period Function



MODEL 1820

- 5Hz to 80MHz reading guaranteed—100MHz typical
- Period measurements from 5Hz to 1MHz
- Period average, auto and manual positions
- One PPM resolution
- Totalizes to 999999 plus overflow
- Elapsed time measurements from .01 to 9999.99 seconds plus overflow
- One-megohm input resistance
- Bright .43" high LED readouts

BK PRECISION

Call For Our Price



THE TEST EQUIPMENT SPECIALISTS

TOLL FREE HOT LINE
800-223-0474

54 WEST 45th STREET, NEW YORK, N.Y. 10036 212-687-2224

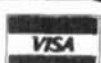

ADVANCE
ELECTRONICS

Palomar Engineers

1520G Industrial Avenue, Escondido, CA 92025
Telephone (714) 747-3363



\$349.95

ANTENNA TUNER

New Low Profile Design
Here is a new tuner that puts more power into your antenna, works from 160 through 10 meters, handles full legal power and then some, and works with coax, single wire and balanced lines. And it lets you tune up without going on the air!

R-X NOISE BRIDGE \$55.00

- Learn the truth about your antenna.
- Find its resonant frequency.
- Adjust it to your operating frequency quickly and easily.

If there is one place in your station where you cannot risk uncertain results, it is in your antenna.

IC KEYER \$117.50

All the desirable features are built into this compact self-contained unit. Sends manual, semi-automatic, dot memory, squeeze, and iambic. Speeds 5-50 wpm. Built-in sidetone, speaker, speed and volume controls.

ANTENNA BALUNS

- Model 1K **\$32.50**
1 Kw CW, 3 Kw PEP input.
- Model 2K **\$42.50**
2 Kw CW, 6 Kw PEP input.
- Beam Balun **\$47.50**
2 Kw CW, 6 Kw PEP input.
Adjustable U bolt for mounting on rotary beams.

VLF CONVERTER \$59.95

- New device open up the world of Very Low Frequency radio.
- Gives reception of the 1750 meter band at 160-190 KHz where transmitters of one watt power can be operated without FCC license.
- Also covers the navigation radiobeacon band, standard frequency broadcasts, ship-to-shore communications, and the European low frequency broadcast band.

NEW!

1750 METER XMTR \$145.00



- Main transmitter assembly factory wired and tested.
- Antenna tuning assembly can be wired and mounted on your breadboard in less than an hour.
- Meets all F.C.C. requirements.
- For use in U.S.A. only. Not for Canada.

LOOP ANTENNA

- Low noise reception.
- Nulls out interference.
- Accurate direction finder.
- Rotates 360° in azimuth. Tilts ±90° in elevation.
- Superb nulls.
- Loop amplifier connects to your receiver or to your VLF converter.
- Plug-in loops available for:
1600-5000 KHz (160/80 meter amateur bands)
550-1600 KHz (Broadcast Band)
150-550 KHz (VLF, 1750 meter band)
40-150 KHz (WWVB, Loran)
10-40 KHz (Omega)
5-15 MHz (Model HF-1)
Loop Amplifier **\$67.50**; Plug-in Loop Antenna **\$47.50** each.

These items are stocked for Christmas delivery. Order today direct or from your favorite dealer. Include \$3 shipping/handling (\$4 for IC Keyer, \$10 for Antenna Tuner). Add sales tax in Calif. Free catalog on request.

**You can't
tell the players
without a
scorecard!**

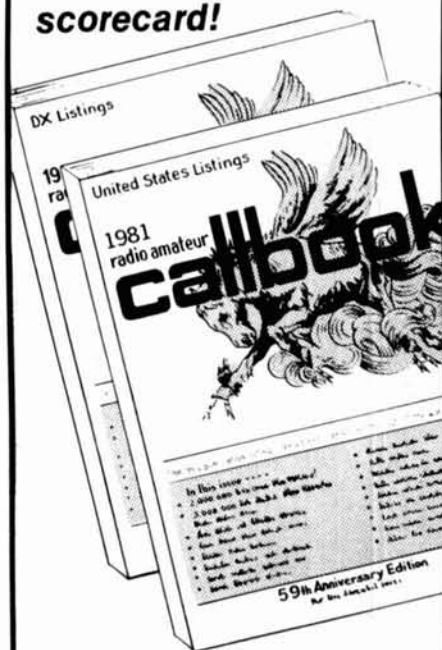

Order today!

**NEW 1981
RADIO AMATEUR CALLBOOKS
READY DECEMBER 1st!**

The latest editions will be published soon! World-famous Radio Amateur Callbooks, the most respected and complete listing of radio amateurs. Lists calls, license classes, address information. Loaded with special features such as call changes, prefixes of the world, standard time charts, world-wide QSL bureaus, and more. The U.S. Edition features over 400,000 listings, with over 100,000 changes from last year. The Foreign Edition has over 300,000 listings, over 90,000 changes. The new 1981 Callbooks will be available on December 1, 1980. Place your order now.

	Each	Shipping	Total
<input type="checkbox"/> US Callbook	\$17.95	\$2.55	\$20.50
<input type="checkbox"/> Foreign Callbook	\$16.95	\$2.55	\$19.50

Order both books at the same time for \$37.45 including shipping.

Order from your dealer or directly from the publisher. All direct orders add \$2.55 for shipping. Illinois residents add 5% sales tax.



**SPECIAL LIMITED OFFER!
Amateur Radio
Emblem Patch
only \$2.50 postpaid**

Pegasus on blue field, red lettering. 3" wide x 3" high. Great on jackets and caps. Sorry, no call letters.

ORDER TODAY!

RADIO AMATEUR callbook INC.



Dept.F
925 Sherwood Drive
Lake Bluff, IL 60044, USA

Alaska Microwave Labs

4335 E. 5TH STREET
ANCHORAGE, ALASKA 99504
(907) 338-0340



NEW! GaAs FETS

**MGF 1400 NF 2.0DB
AT 4GHZ MAG 15DB
\$28.50**

**MGF 1412 NF .8DB
AT 4GHZ MAG 18DB
\$75.00**



TRANSISTORS

MRF901 FT4.5GHZ \$3.00
BFR90 FT5.0GHZ \$3.00
NEC 02137 FT4.5GHZ \$3.25

HOT CARRIER DIODES

MBD101 UHF—MICROWAVE \$1.50
ND4131 4GHZ NF—5.75 DB \$19.00
4GHZ NF— 6.5 DB \$2.00

CHIP CAPACITORS

1.2, 2.2, 3.3, 4.7, 6.8, 10, 18, 22, 27,
47, 100, 120, 180, 220, 270, 330,
390, 470, 560, 680, 820, 1000,
1200, 1800, 3900, 8200 \$.60

RF - IF I.C.

MWA-110
RF-IF AMPLIFIER I.C.
1 TO 400 MC 14 DB GAIN TYP
3 TERMINAL IN, OUT, & GROUND \$7.95

DUAL GATE MOSFET

RCA 40673 \$1.50

COAX CONNECTORS

SMA CHASSIS MOUNT SQUARE FLANGE \$5.90
SMA PLUG FOR RG-58 \$6.57
SMA PLUG FOR RG-174 \$6.57
TYPE N CHASSIS MOUNT SQUARE FLANGE \$3.20
TYPE N PLUG FOR RG-9/RG-8 \$3.69

FEED-THRU CAPACITORS

500 PF \$.50

TEFLON CIRCUIT BOARD

APPROX. 3.5" x 5.0" x .010 \$5.50
APPROX. 3.5" x 5.0" x .0312 \$6.50

CHIP RESISTORS

50 OHM 1/2 WATT \$1.50

PISTON TRIMMERS

TR100 201-01M 5-3PF() 1-8PF() \$2.50



**OPEN AT 8PM EST
CLOSED AT 8PM PST**

IF YOU DO NOT SEE

WHAT YOU WANT ASK

**ORDERS ARE POSTAGE PAID
COD-VISA-MASTERCHARGE**

Introducing

The ICM TV-4300

SATELLITE RECEIVER

HIGH PERFORMANCE LOW PRICE



International's TV-4300 is a high performance satellite receiver that tunes all channels within the 3.7 — 4.2 GHz band. Standard dual audio output provided at 6.2 and 6.8 MHz. Others available.

The TV-4300 is a fully packaged and assembled receiver complete with a built-in LNA power supply, built-in AFC, tuner, control circuitry and power cable. All output levels compatible with video monitor and VTR input. Easy to use! Simple tuning!

\$995.00

Select These Options

Remote tuning control \$99.50

Six frequency, crystal control,
audio with stereo output.
(Factory installed 6.2 and 6.8 MHz
crystals supplied) \$89.50

Other audio frequency crystals \$9.50 ea.

Model TV-4300A . . . supplied with
remote control and six frequency,
crystal control, audio with
stereo output \$1,149.00



Write for information.



INTERNATIONAL CRYSTAL MANUFACTURING CO., INC.
10 N. Lee, Oklahoma City, Oklahoma 73102, 405-236-3741

MHz electronics

1900 MHz to 2500 MHz DOWN CONVERTER

This receiver is tunable over a range of 1900 to 2500 mc and is intended for amateur radio use. The local oscillator is voltage controlled (i.e.) making the i-f range approximately 54 to 88 mc (Channels 2 to 7).

PC BOARD WITH DATA	\$19.99
PC BOARD WITH CHIP CAPACITORS 13	\$44.99
PC BOARD WITH ALL PARTS FOR ASSEMBLY	\$69.99
PC BOARD WITH ALL PARTS FOR ASSEMBLY PLUS 2N6603	\$89.99
PC BOARD ASSEMBLED AND TESTED	\$99.99
PC BOARD WITH ALL PARTS FOR ASSEMBLY, POWER SUPPLY AND ANTENNA	\$159.99
POWER SUPPLY ASSEMBLED AND TESTED	\$49.99
YAGI ANTENNA 4' LONG APPROX. 20 TO 23 dB GAIN	\$59.99
YAGI ANTENNA 4' WITH TYPE (N, BNC, SMA Connector)	\$64.99
2300 MHz DOWN CONVERTER Includes converter mounted in antenna, power supply, plus 90 DAY WARRANTY	\$259.99
OPTION #1 MRF902 in front end. (7 dB noise figure)	\$299.99
OPTION #2 2N6603 in front end. (5 dB noise figure)	\$359.99
2300 MHz DOWN CONVERTER ONLY	
10 dB Noise Figure 23 dB gain in box with N conn. Input F conn. Output	\$149.99
7 dB Noise Figure 23 dB gain in box with N conn. Input F conn. Output	\$169.99
5 dB Noise Figure 23 dB gain in box with SMA conn. Input F conn. Output	\$189.99
DATA IS INCLUDED WITH KITS OR MAY BE PURCHASED SEPARATELY	\$15.00

Shipping and Handling Cost:

Receiver Kits add \$1.50, Power Supply add \$2.00, Antenna add \$5.00, Option 1/2 add \$3.00, For complete system add \$7.50.

Replacement Parts:

MRF901	\$5.00	.001 chip caps	\$2.00
2N6603	\$12.00	PC Board only	\$25.00 with data
MBD101	\$2.00		

★ INTRODUCING THE HOWARD/COLEMAN TVRO CIRCUIT BOARDS ★

(Satellite Receiver Boards)

DUAL CONVERSION BOARD	\$25.00
This board provides conversion from the 3.7-4.2 band first to 900 MHz where gain and bandpass filtering are provided and, second, to 70 MHz. The board contains both local oscillators, one fixed and the other variable, and the second mixer. Construction is greatly simplified by the use of Hybrid IC amplifiers for the gain stages. Bare boards cost \$25 and it is estimated that parts for construction will cost \$270. (Note: The two AvanteK VTO's account for \$225 of this cost.)	
47 pF CHIP CAPACITORS	\$6.00
For use with dual conversion board. Consists of 6 — 47 pF.	
70 MHz IF BOARD	\$25.00
This circuit provides about 43 dB gain with 50 ohm input and output impedance. It is designed to drive the HOWARD/COLEMAN TVRO Demodulator. The on-board band pass filter can be tuned for bandwidths between 20 and 35 MHz with a passband ripple of less than 1/2 dB. Hybrid ICs are used for the gain stages. Bare boards cost \$25. It is estimated that parts for construction will cost less than \$40.	
.01 pF CHIP CAPACITORS	\$7.00
For use with 70 MHz IF Board. Consists of 7 — .01 pF.	
DEMODULATOR BOARD	\$40.00
This circuit takes the 70 MHz center frequency satellite TV signals in the 10 to 200 millivolt range, detects them using a phase locked loop, de-emphasizes and filters the result and amplifies the result to produce standard NTSC video. Other outputs include the audio subcarrier, a DC voltage proportional to the strength of the 70 MHz signal, and AFC voltage centered at about 2 volts DC. The bare boards cost \$40 and total parts cost less than \$30.	
SINGLE AUDIO	\$15.00
This circuit recovers the audio signals from the 6.8 MHz frequency. The Miller 9051 coils are tuned to pass the 6.8 MHz subcarrier and the Miller 9052 coil tunes for recovery of the audio.	
DUAL AUDIO	\$25.00
Duplicate of the single audio but also covers the 6.2 range.	
DC CONTROL	\$15.00
This circuit controls the VTO's, AFC and the S Meter.	

TOTAL COSTS

Using the HOWARD/COLEMAN boards and the recommended parts, it is easily possible to build the complete receiver (excluding LNA) for less than \$600. Construction time is a few evenings and the tune up is minimal.

TERMS:

WE REGRET WE NO LONGER ACCEPT BANK CARDS.

PLEASE SEND POSTAL MONEY ORDER, CERTIFIED CHECK, CASHIER'S CHECK OR MONEY ORDER.

PRICES SUBJECT TO CHANGE WITHOUT NOTICE. WE CHARGE 15% FOR RESTOCKING ON ANY ORDER.

ALL CHECKS AND MONEY ORDERS IN US FUNDS ONLY.

ALL ORDERS SENT FIRST CLASS OR UPS.

ALL PARTS PRIME AND GUARANTEED.

WE WILL ACCEPT COD ORDERS FOR \$25.00 OR OVER, ADD \$1.50 FOR COD CHARGE.

PLEASE INCLUDE \$1.50 MINIMUM FOR SHIPPING OR CALL FOR CHARGES.

WE ALSO ARE LOOKING FOR NEW AND USED TUBES,

TEST EQUIPMENT, COMPONENTS, ETC.

WE ALSO SWAP OR TRADE.

FOR CATALOG SEE JANUARY, 1980, 73 Magazine, 10 Pages.

(602) 242-3037

(602) 242-8916

2111 W. Camelback
Phoenix, Arizona 85015

NEW — TOLL-FREE NO. 800-528-0180 — please, orders only!

MHz electronics

FAIRCHILD VHF AND UHF PRESCALER CHIPS

95H90DC	350 MHz Prescaler Divide by 10/11	\$9.50
95H91DC	350 MHz Prescaler Divide by 5/6	9.50
11C90DC	650 MHz Prescaler Divide by 10/11	16.50
11C91DC	650 MHz Prescaler Divide by 5/6	16.50
11C83DC	1 GHz Divide by 248/256 Prescaler	29.90
11C70DC	600 MHz Flip/Flop with reset	12.30
11C58DC	ECL VCM	4.53
11C44DC/MC4044	Phase Frequency Detector	3.82
11C24DC/MC4024	Dual TTL VCM	3.82
11C06DC	UHF Prescaler 750 MHz D Type Flip/Flop	12.30
11C05DC	1 GHz Counter Divide by 4	74.35
11C01FC	High Speed Dual 5-4 input NO/NOR Gate	15.40

WISPER FANS

This fan is super quiet, efficient cooling where low acoustical disturbance is a must. Size 4.68" x 4.68" x 1.50", Impedance protected, 50/60 Hz. 120 Vac. \$9.99

TRW BROADBAND AMPLIFIER MODEL CA615B

Frequency response 40 MHz to 300 MHz
Gain: 300 MHz 16 dB Min., 17.5 dB Max.
50 MHz 0 to -1 dB from 300 MHz
Voltage: 24 volts dc at 220 ma max. \$19.99

CARBIDE — CIRCUIT BOARD DRILL BITS FOR PC BOARDS

Size: 35, 42, 47, 49, 51, 52	\$2.15
Size: 53, 54, 55, 56, 57, 58, 59, 61, 63, 64, 65	1.85
Size: 66	1.90
Size: 1.25 mm, 1.45 mm	2.00
Size: 3.20 mm	3.58

CRYSTAL FILTERS: TYCO 001-19880 same as 2194F

10.7 MHz Narrow Band Crystal Filter
3 dB bandwidth 15 kHz min. 20 dB bandwidth 60 kHz min. 40 dB bandwidth 150 kHz min.
Ultimate 50 dB: Insertion loss 1.0 dB max. Ripple 1.0 dB max. Ct. 0 + / - 5 pf 3600 ohms. \$5.95

MURATA CERAMIC FILTERS

Models: SFD-455D 455 kHz	\$3.00
SFB-455D 455 kHz	2.00
CFM-455E 455 kHz	7.95
SFE-10.7 10.7 MHz	5.95

TEST EQUIPMENT — HEWLETT PACKARD — TEKTRONIX — ETC.

Hewlett Packard:		
491C	TWT Amplifier 2 to 4 Gc 1 watt 30 dB gain	\$1150.00
608C	10 to 480 mc .1 uv to .5 V into 50 ohms Signal Generator	500.00
608D	10 to 420 mc .1 uv to .5 V into 50 ohms Signal Generator	500.00
612A	450 to 1230 mc .1 uv to .5 V into 50 ohms Signal Generator	750.00
614A	900 to 2100 mc Signal Generator	500.00
616A	1.8 to 4.2 Gc Signal Generator	400.00
616B	1.8 to 4.2 Gc Signal Generator	400.00
618A	3.8 to 7.2 Gc Signal Generator	400.00
618B	3.8 to 7.2 Gc Signal Generator	400.00
620A	7 to 11 Gc Signal Generator	400.00
623B	Microwave Test Set	900.00
626A	10 to 15 Gc Signal Generator	2500.00
695A	12.4 to 18 Gc Sweep Generator	900.00
Alltech:		
473	225 to 400 mc AM/FM Signal Generator	750.00
Singer:		
MF5/VR-4	Universal Spectrum Analyzer with 1 kHz to 27.5 mc Plug In	1200.00
Keltek:		
XR630-100	TWT Amplifier 8 to 12.4 Gc 100 watts 40 dB gain	9200.00
Polarad:		
2038/2436/1102A	Calibrated Display with an SSB Analysis Module and a 10 to 40 mc Single Tone Synthesizer	1500.00

HAMLIN SOLID STATE RELAYS

120 Vac at 40 Amps.
Input Voltage 3 to 32 Vdc.

240 Vac at 40 Amps.
Input Voltage 3 to 32 Vdc.
Your Choice \$4.99

RF TRANSISTORS

TYPE	PRICE	TYPE	PRICE	TYPE	PRICE
2N1561	\$15.00	2N5590	\$8.15	MM1550	\$10.00
2N1562	15.00	2N5591	11.85	MM1552	50.00
2N1692	15.00	2N5637	22.15	MM1553	56.50
2N1693	15.00	2N5641	6.00	MM1601	5.50
2N2632	45.00	2N5642	10.05	MM1602/2N5842	7.50
2N2857JAN	2.52	2N5643	15.82	MM1607	8.85
2N2876	12.35	2N5645	12.38	MM1661	15.00
2N2880	25.00	2N5764	27.00	MM1669	17.50
2N1693	7.00	2N5842	8.78	MM1943	3.00
2N2947	18.35	2N5849	21.29	MM2605	3.00
2N2948	15.50	2N5862	51.91	MM2608	5.00
2N2949	3.90	2N5913	3.25	MM8006	2.23
2N2950	5.00	2N5922	10.00	MMCM918	20.00
2N3287	4.30	2N5942	46.00	MMT72	1.17
2N3294	1.15	2N5944	8.92	MMT74	1.17
2N3301	1.04	2N5945	12.38	MMT2857	2.63
2N3302	1.05	2N5946	14.69	MRF245	33.30
2N3304	1.48	2N6080	7.74	MRF247	33.30
2N3307	12.60	2N6081	10.05	MRF304	43.45
2N3309	3.90	2N6082	11.30	MRF420	20.00
2N3375	9.32	2N6083	13.23	MRF450	11.85
2N3553	1.57	2N6084	14.66	MRF450A	11.85
2N3755	7.20	2N6094	7.15	MRF454	21.83
2N3818	6.00	2N6095	11.77	MRF458	20.68
2N3866	1.09	2N6096	20.77	MRF475	5.00
2N3866JAN	2.80	2N6097	29.54	MRF476	5.00
2N3866JANTX	4.49	2N6136	20.15	MRF502	1.08
2N3924	3.34	2N6166	38.80	MRF504	6.95
2N3927	12.10	2N6265	75.00	MRF509	4.90
2N3950	26.86	2N6266	100.00	MRF511	8.15
2N4072	1.80	2N6439	45.77	MRF901	3.00
2N4135	2.00	2N6459/PT9795	18.00	MRF5177	21.62
2N4261	14.60	2N6603	12.00	MRF8004	1.60
2N4427	1.20	2N6604	12.00	PT4186B	3.00
2N4957	3.82	A50-12	25.00	PT4571A	1.50
2N4958	2.92	BFR90	5.00	PT4612	5.00
2N4959	2.23	BLY568C	25.00	PT4628	5.00
2N4976	19.00	BLY568CF	25.00	PT4640	5.00
2N5090	12.31	CD3495	15.00	PT8659	10.72
2N5108	4.03	HEP76/S3014	4.95	PT9784	24.30
2N5109	1.66	HEPS3002	11.30	PT9790	41.70
2N5160	3.49	HEPS3003	29.88	SD1043	5.00
2N5179	1.05	HEPS3005	9.95	SD1116	3.00
2N5184	2.00	HEPS3006	19.90	SD1118	5.00
2N5216	47.50	HEPS3007	24.95	SD1119	3.00
2N5583	4.55	HEPS3010	11.34	TA7993	75.00
2N5589	6.82	HEPS5026	2.56	TA7994	100.00
		HP35831E/		TRWMRA2023-1.5	42.50
		HXTR5104	50.00	40281	10.90
		MM1500	32.20	40282	11.90
				40290	2.48

CHIP CAPACITORS

1pf	27pf	220pf	1200pf
1.5pf	33pf	240pf	1500pf
2.2pf	39pf	270pf	1800pf
2.7pf	47pf	300pf	2200pf
3.3pf	56pf	330pf	2700pf
3.9pf	68pf	360pf	3300pf
4.7pf	82pf	390pf	3900pf
5.6pf	100pf	430pf	4700pf
6.8pf	110pf	470pf	5600pf
8.2pf	120pf	510pf	6800pf
10pf	130pf	560pf	8200pf
12pf	150pf	620pf	.010mf
15pf	160pf	680pf	.012mf
18pf	180pf	820pf	.015mf
22pf	200pf	1000pf	.018mf

We can supply any value chip capacitors you may need.

PRICES

1 to 10	\$1.99
11 - 50	1.49
51 - 100	1.00
101 - 1,000	.75
1,001 up	.50

ATLAS CRYSTAL FILTERS FOR ATLAS HAM GEAR

5.52-2.7/8
5.595-2.7/8/U
5.595-500/4/CW
5.595-2.7LSB
5.595-2.7USB
5.645-2.7/8
9.0USB/CW

YOUR CHOICE \$24.95

NEW — TOLL-FREE NO. 800-528-0180 — please, orders only!

MHz electronics

MOTOROLA Semiconductor The RF Line

MRF454 \$21.83

NPN SILICON RF POWER TRANSISTORS

... designed for power amplifier applications in industrial, commercial and amateur radio equipment to 30 MHz.

- Specified 12.5 Volt, 30 MHz Characteristics -
Output Power = 80 Watts
Minimum Gain = 12 dB
Efficiency = 50%

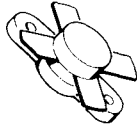

NPN SILICON RF POWER TRANSISTOR

... designed primarily for use in large-signal output amplifier stages. Intended for use in Citizen-Band communications equipment operating at 27 MHz. High breakdown voltages allow a high percentage of up-modulation in AM circuits.

MRF472

\$2.50

- Specified 12.5 V, 27 MHz Characteristics -
Power Output = 4.0 Watts
Power Gain = 10 dB Minimum
Efficiency = 65% Typical

MRF475

NPN SILICON RF POWER TRANSISTOR

... designed primarily for use in single sideband linear amplifier output applications in citizens band and other communications equipment operating to 30 MHz.

- Characterized for Single Sideband and Large-Signal Amplifier Applications Utilizing Low-Level Modulation.
- Specified 13.6 V, 30 MHz Characteristics -
Output Power = 12 W (PEP)
Minimum Efficiency = 40% (SSB)
Output Power = 4.0 W (CW)
Minimum Efficiency = 50% (CW)
Minimum Power Gain = 10 dB (PEP & CW)
- Common Collector Characterization

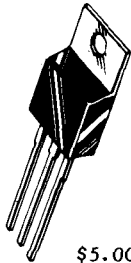

\$5.00

MRF458 \$20.68

NPN SILICON RF POWER TRANSISTOR

... designed for power amplifier applications in industrial, commercial and amateur radio equipment to 30 MHz.

- Specified 12.5 Volt, 30 MHz Characteristics -
Output Power = 80 Watts
Minimum Gain = 12 dB
Efficiency = 50%
- Capable of Withstanding 30:1 Load VSWR @ Rated P_{OUT} and V_{CC}

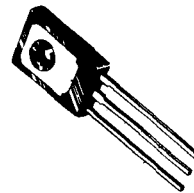

MHW710 - 2

\$46.45
440 to 470MC

UHF POWER AMPLIFIER MODULE

... designed for 12.5 volt UHF power amplifier applications in industrial and commercial FM equipment operating from 400 to 512 MHz.

- Specified 12.5 Volt, UHF Characteristics -
Output Power = 13 Watts
Minimum Gain = 19.4 dB
Harmonics = 40 dB
- 50 Ω Input/Output Impedance
- Guaranteed Stability and Ruggedness
- Gain Control Pin for Manual or Automatic Output Level Control
- Thin Film Hybrid Construction Gives Consistent Performance and Reliability

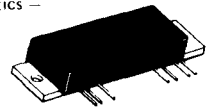

Tektronix Test Equipment

B	Wideband High Gain Plug In	\$ 51.00
CA	Dual Trace Plug In	140.00
K	Fast Rise DC Plug In	63.00
N	Sampling Plug In	200.00
R	Transistor Rise-time Plug In	116.00
W	High Gain Differential Comparator Plug In	283.00
TU-2	Test Load Plug In For 530/540/550 Main Frames	50.00
1A2	Wideband Dual Trace Plug In	215.00
151	Sampling Unit With 350PS Rise-time DC to 1GHz	710.00
2A61	AC Differential Plug In	133.00
353	Dual Trace Sampling DC to 1GHz Plug In	250.00
3576	Dual Trace Sampling DC to 875MHz Plug In	250.00
3777A	Sampling Sweep Plug In	250.00
3L10	Spectrum Analyzer 1 to 30MHz Plug In	1000.00
50	Amplifier Plug In	50.00
51	Sweep Plug In	50.00
538	Wideband High Gain Plug In	25.00
53/54B	Wideband High Gain Plug In	45.00
53/54C	Dual Trace Plug In	112.50
53/54D	High Gain DC Differential Plug In	38.00
53/54E	Wideband DC Differential Plug In	48.00
53/54L	Fast Rise High Gain Plug In	68.00
84	Test Plug In For 500/561 Main Frames	75.00
107	Square Wave Generator .4 to 1MHz	48.00
RM122	Preamplifier 2Hz to 40kHz	63.00
123	AC Coupled Preamplifier	25.00
127	Power Supply For 2 Plug In's	148.00
131	Current Probe Amplifier	50.00
184	Time Mark Generator	363.00
R240	Program Control Unit	150.00
280	Trigger Countdown Unit	84.00
465	Portable Dual Trace 50MHz Scope	2000.00
465	Portable Dual Trace 100MHz Scope	2500.00
503	DC to 450kHz Scope Rack Mount	250.00
535A	DC to 15MHz Scope Rack Mount	263.00
543	DC to 33MHz Scope	300.00
561	DC to 10MHz Scope Rack Mount	150.00
561A	DC to 10MHz Scope Rack Mount	200.00

Scopes with Plug-ins

561A	DC to 10MHz Scope with a 3576 Dual Trace DC to 875MHz Sampling Plug In and a 3777A Sweep Plug In. Rack Mount	600.00
565	DC to 10MHz Dual Beam Scope with a 2A61 Diff. and a 2A61 Diff. Plug In's	900.00
581	DC to 80MHz Scope with a 82 Dual Trace High Gain Plug In	650.00

Tubes

2E26	\$ 5.00	4CX350FJ	\$116.00	6146W	12.00
3-500Z	102.00	4CX1000A	300.00	6159	10.60
3-1090Z	268.00	4CX1500B	350.00	6161	75.00
3E2B/866A	5.00	4CX1500A	740.00	6293	18.50
1X2500A3	150.00	4E27	50.00	6360	6.95
4-65A	45.00	4X150A	41.00	6907	40.00
4-125A	58.50	4X150D	52.00	6939	14.75
4-250A	66.50	4X150E	74.00	7365	12.00
4-400A	71.00	5Z2B/T160L	19.00	7984	10.40
4-1000A	184.00	6L6	5.00	8072	49.00
5-500A	145.00	6L06	5.00	8106	2.00
4CX250R	65.00	6L1A	12.95	8156	7.85
4CX250F/G	55.00	613	29.00	8276	127.70
4CX250K	113.00	5894/A	42.00	8295/PL172	328.00
4CX250R	92.00	6146	5.00	8458	25.75
4CX300A	147.00	6146A	6.00	8560A/AS	50.00
4CX350A	107.00	6146B/8295A	7.00	8908	9.00
				8950	4.00

NEW — TOLL-FREE NO. 800-528-0180 — please, orders only!

STEP UP TO TELREX

Professionally Engineered Antenna Systems

Single transmission line "TRI-BAND" ARRAY

MONARCH
TB5EM/4KWP

ILLUSTRATION BALUN



ILLUSTRATION TRAP



By the only test that means anything... on the air comparison... this array continues to outperform all competition... and has for two decades. Here's why... Telrex uses a unique trap design employing 20 HiQ 7500V ceramic condensers per antenna. Telrex uses 3 optimum-spaced, optimum-tuned reflectors to provide maximum gain and true F/B Tri-band performance.

For technical data and prices on complete Telrex line, write for Catalog PL 7



JAN CRYSTALS

HOLD THE FREQUENCY

- CB
- CB standard
- 2 meter
- Scanners
- Amateur Bands
- General Communication
- Industry
- Marine VHF
- Micro processor crystals

Send 10¢ for our latest catalog. Write or phone for more details.

2400 Crystal Drive
Ft. Myers, Florida 33907
all phones (813) 936-2397

Handful of POWER

Ask about our 50 and 100 watt amplifiers for use with low-power hand-held radios!



Give your low-power 2-meter rig real punch by delivering a potent 25-watt signal with only two watts of drive (also available set up for 200 milli-watts drive). Compact and convenient to mount VoCom's Model 2C025 is ideal for car, boat, or anywhere you've got a 12 VDC source. At only \$84.95 (\$99.95 for 200 mW drive), it's the perfect companion for your Drake, Encomm, Henry, Icom, Kenwood, Motorola, Standard, Wilson, Yaesu or other 2-meter FM portable!

- .2 or 2 watt nominal drive (specify)
- 2 watt model delivers 15-20 watts with only one watt of drive
- 10 MHz bandwidth for CAP or MARS
- Meets all applicable FCC specifications
- 200 mW drive model permits operating Icom IC-2A or Yaesu FT-207R on their battery-saving low-power mode
- Only \$84.95 (\$99.95 for 200 mW drive)

Available now from your local amateur radio dealer or order direct

VoCom Box 219, Prospect Heights, IL 60070
PRODUCTS CORPORATION (312) 459-3680



Bill Orr's famous Radio Handbook 21st Edition

Often referred to as the "California Handbook," Bill Orr's 21st edition of the RADIO HANDBOOK is a must for every ham's bookshelf. 1080 pages cover extensively everything from antennas to zero bias tubes. In addition you'll find new and enlarged sections on frequency synthesizers, IC design, HF and VHF linear amplifier construction and NBVM. Radio theory, construction projects, tests and measurements, and reference data are all here, under one cover. W6SAI and more than 20 other notable Amateurs have combined their talents to produce one of the finest and most complete Amateur Radio reference sources ever put in print. 1080 pages. © 1978.

☐ 24034

Hardbound \$21.50

Call 1-800-258-5353 or Use handy order form on page 92.

Ham Radio's Bookstore
Greenville, N. H. 03048

Please add \$1 for shipping



KENWOOD

and
Have Control(s)

MADISON

Electronics Supply, Inc.

1508 McKinney, Houston, TX 77010
(713) 658-0268

TS 130A — \$759.95

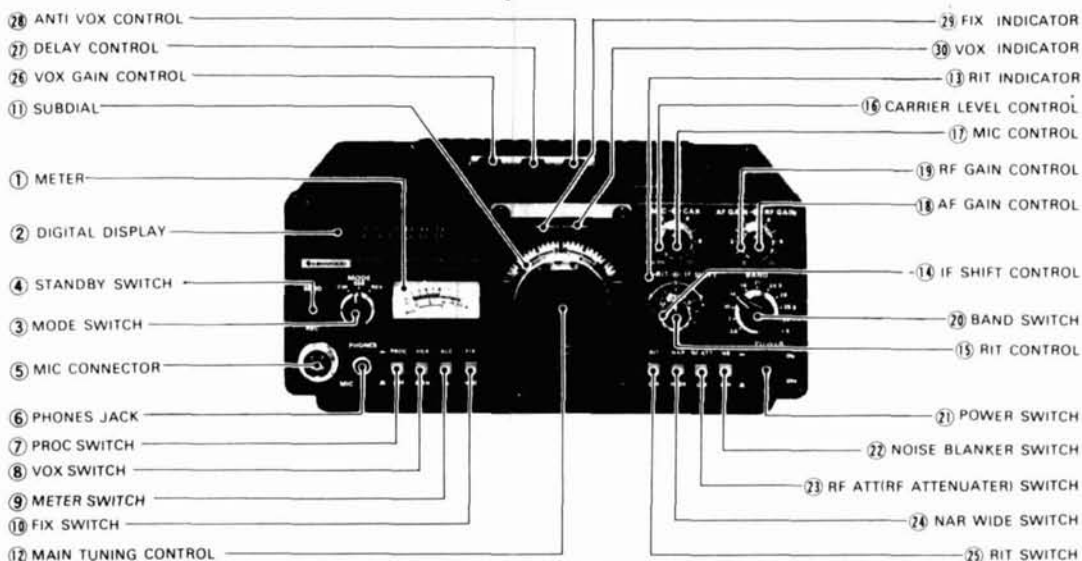

CALL FOR QUOTES

Plus Accessories: TS130V — \$599.95; DFC230 — \$279.95; AT130 — \$139.95; YK88SN — \$59.95

WANTED FOR CASH

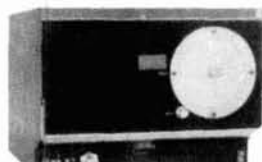

490-T Ant. Tuning Unit
(Also known as CU1658
and CU1669) -



618-T Transceiver
(Also known as MRC95,
ARC94, ARC102, or VC102)

4CX150
4CX250
4CX300A
4CX350A

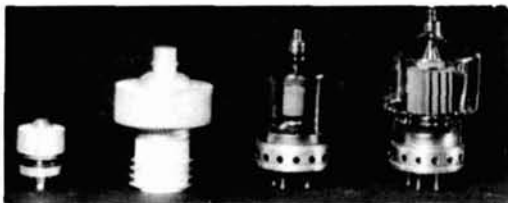

4CX1000
4CX1500
4CX3000
4CX5000

4CX10,000 4-65 4-250 4-1000
5CX1500 4-125A 4-400 304TL

Other tubes and Klystrons also wanted.

Highest price paid for these units. Parts purchased. Phone **Ted, W2KUW collect**. We will trade for new amateur gear. GRC106, ARC105, ARC112, ARC114, ARC115, ARC116, and some aircraft units also required.

DCO, INC.

10 Schuyler Avenue
Call Toll Free
800-526-1270

No. Arlington, N. J. 07032
(201) 998-4246
Evenings (201) 998-6475

HUSTLER ANTENNAS

5BTV	5-Band trap vertical 10-80 m., reg.	\$139.95	...	\$125.95
4BTV	4-Band trap vertical 10-40 m., reg.	\$109.95	...	98.96
BM-1	Bumper mount, reg.	\$18.95	...	17.06
MO-1	Mast, fold-over, deck mounting, reg.	\$22.95	...	20.66
MO-2	Mast, fold-over, bumper mount, reg.	\$22.95	...	20.66
RM-75	Resonator, 75 meters, 400 watt, reg.	\$18.95	...	17.06
RM-40	Resonator, 40 meters, 400 watt, reg.	\$16.95	...	15.26
RM-40S	Super resonator, 40 meters, KW, reg.	\$24.95	...	22.46
RM-20	Resonator, 20 meters, 400 watt, reg.	\$14.95	...	13.46
RM-20S	Super resonator, 20 meters, KW, reg.	\$21.95	...	19.76
RM-15	Resonator, 15 meters, 400 watt, reg.	\$10.95	...	9.86
RM-10	Resonator, 10 meters, 400 watt, reg.	\$10.95	...	9.86
CG-144	Mobile 2 meter colinear, w/o mount, reg.	\$28.95	...	26.06
CGT-144	2 meter colinear w/trunk mount, reg.	\$45.95	...	41.36

PALOMAR ENGINEERS

		Price	Shpg.
R-X	Noise bridge	\$ 55.00	\$2.00
VLF	Converter	59.95	2.00
IK	Toriod balun, 3 KW SSB, 1:1 or 4:1	32.50	2.00
2K	Toriod balun, 6 KW SSB, 1:1 or 4:1	42.50	2.00
IC	Keyer, battery operated	117.50	3.00
Loop Antenna	plug-in units, 160/80, BCB, VLF.	47.50	2.00
Loop Amplifier		67.50	2.00
Tuner	— 10-60 meters, built-in noise bridge	299.95	6.50
CW Filter	8 pole IC	39.95	2.00

ALSO IN STOCK

Antenna Components • Larsen Antennas
Centurion International Rubber Duck Antennas

WRITE FOR A FREE COPY OF OUR CATALOG

MASTER CHARGE VISA

All items F.O.B. Lincoln, \$1.00 minimum shipping. Prices subject to change without notice. Nebraska residents please add 3% tax.

g & c Communications

730 Cottonwood

Lincoln, Nebraska 68510

Be A *Ham Radio* HORIZONS Transceiver

Transmit your favorite magazine to your friends.

Receive the most "alive" magazine in Amateur Radio today.

There's no question about it. **Ham Radio HORIZONS** makes the perfect holiday gift. Look at the great new features: Bill Orr's **Ham Radio Techniques**, K5FUV's **DX Column**, our own **Q&A Section**, and W9KNI's **Diary of a DXer**. Add our exciting new look plus our new emphasis on serving today's **ACTIVE** Amateur and you have an unbeatable gift for all your ham friends.

To make **Ham Radio HORIZONS** even more appealing, we've lowered our prices for this special holiday offer. In fact, to take advantage of all these new features, shouldn't **you** also be starting or extending your own **HORIZONS** subscription? Feel free to add your own name at these low, holiday prices.

Make up your list today and send it along. We'll take it from there. We'll even send an attractive gift card announcing your thoughtfulness.

1st Gift \$10.00
(save \$2.00)

Additional \$8.00
Gift (save \$4.00)

The Ham Radio Publishing Group
Greenville, NH 03048



Yes! Please send my HORIZONS gift subscriptions as indicated. Also send a gift acknowledgement card . . .

\$ _____ is enclosed for _____ subscriptions.

FROM:
My Name _____ Call _____

Address _____

City _____ State _____ Zip _____

Master Charge Account _____

VISA _____ Expires _____

Start or
 Renew my HORIZONS
subscription.

Bill me after
January 1, 1981

1st GIFT New Subscription
 Renewal

SEND TO:

Name _____ Call _____

Address _____

City _____ State _____ Zip _____

2nd GIFT New Subscription
 Renewal

SEND TO:

Name _____ Call _____

Address _____

City _____ State _____

For additional gifts give complete information on separate sheet of paper and return with above order.

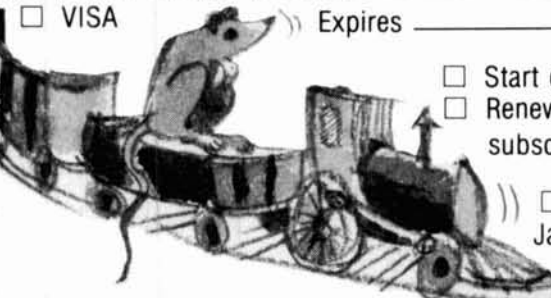

First family
of power...

ALPHA



Photo By RIC HELSTROM

Glenn Eyring, Garden of the Gods, an ETO's back yard

THE VERY FINEST ANSWER TO YOUR NEED for one to two kilowatts of solid HF power: a superlative **ALPHA** linear amplifier - FIRST in performance, in convenience, in quality and durability.

Brute RF power without time limit, whisper-quiet operation, instant no-tune-up bandchanging, high speed

break-in (QSK), the ability to cover any newly-assigned HF band - there's an **ALPHA** perfectly suited to YOUR requirements.

ALPHA: power in a class by itself. For complete details, contact your **ALPHA** dealer or ETO direct.



EHRHORN TECHNOLOGICAL OPERATIONS, INC.
BOX 708, CAÑON CITY, CO 81212 (303) 275-1613



Ham Radio's guide to help you find your local

Arizona

POWER COMMUNICATIONS CORPORATION
6012 N. 27TH AVE.
PHOENIX, AZ 85017
602-242-6030 or 242-8990
Arizona's #1 "Ham" Store. Yaesu, Kenwood, Icom and more.

California

C & A ELECTRONIC ENTERPRISES
2210 S. WILMINGTON AVE.
SUITE 105
CARSON, CA 90745
213-834-5868
Not The Biggest, But The Best —
Since 1962.

JUN'S ELECTRONICS
11656 W. PICO BLVD.
LOS ANGELES, CA 90064
213-477-1824 Trades
714-463-1886 San Diego
The Home of the One Year Warranty
— Parts at Cost — Full Service.

QUEMENT ELECTRONICS
1000 SO. BASCOM AVENUE
SAN JOSE, CA 95128
408-998-5900
Serving the world's Radio
Amateurs since 1933.

SHAVAR RADIO, INC.
1378 S. BASCOM AVENUE
SAN JOSE, CA 95128
408-998-1103
Atlas, Kenwood, Yaesu, KDK,
Icom, Tempo, Wilson, Ten-Tec,
VHF Engineering.

Connecticut

HATRY ELECTRONICS
500 LEDYARD ST. (SOUTH)
HARTFORD, CT 06114
203-527-1881
Connecticut's Oldest Ham
Radio Dealer.

Delaware

DELAWARE AMATEUR SUPPLY
71 MEADOW ROAD
NEW CASTLE, DE 19720
302-328-7728
ICOM, Ten-Tec, Swan, DenTron,
Tempo, Yaesu, Azden, and more.
One mile off I-95, no sales tax.

Florida

AGL ELECTRONICS, INC.
1898 DREW STREET
CLEARWATER, FL 33515
813-461-HAMS
West Coast's only full service
Amateur Radio Store.

AMATEUR RADIO CENTER, INC.
2805 N.E. 2ND AVENUE
MIAMI, FL 33137
305-573-8383
The place for great dependable
names in Ham Radio.

RAY'S AMATEUR RADIO
1590 US HIGHWAY 19 SO.
CLEARWATER, FL 33516
813-535-1416
Atlas, B&W, Bird, Cushcraft,
DenTron, Drake, Hustler, Hy-Gain,
Icom, K.D.K., Kenwood, MFJ, Rohn,
Swan, Ten-Tec, Wilson.

Illinois

AUREUS ELECTRONICS, INC.
1415 N. EAGLE STREET
NAPERVILLE, IL 60540
312-420-8629
"Amateur Excellence"

ERICKSON COMMUNICATIONS, INC.
5456 N. MILWAUKEE AVE.
CHICAGO, IL 60630
Chicago - 312-631-5181
Outside Illinois - 800-621-5802
Hours: 9:30-5:30 Mon, Tu, Wed &
Fri.; 9:30-9:00 Thurs; 9:00-3:00 Sat.

Kansas

ASSOCIATED RADIO
8012 CONSER, P. O. BOX 4327
OVERLAND PARK, KS 66204
913-381-5900
America's No. 1 Real Amateur
Radio Store. Trade - Sell - Buy.

Maryland

THE COMM CENTER, INC.
LAUREL PLAZA, RT. 198
LAUREL, MD 20810
800-638-4486
Kenwood, Drake, Icom, Ten-Tec,
Tempo, DenTron, Swan
& Apple Computers.

Massachusetts

TEL-COM, INC.
675 GREAT ROAD, RT. 119
LITTLETON, MA 01460
617-486-3040
The Ham Store of New England
You Can Rely On.

TUFTS RADIO ELECTRONICS
206 MYSTIC AVENUE
MEDFORD, MA 02155
617-391-3200
New England's friendliest
ham store.

Minnesota

PAL ELECTRONICS INC.
3452 FREMONT AVE. NO.
MINNEAPOLIS, MN 55412
612-521-4662
Midwest's Fastest Growing Ham
Store, Where Service Counts.

New Hampshire

EVANS RADIO, INC.
BOX 893, RT. 3A BOW JUNCTION
CONCORD, NH 03301
603-224-9961
Icom, DenTron & Yaesu dealer.
We service what we sell.

Dealers: *YOU SHOULD BE HERE TOO!*
Contact Ham Radio now for complete details.

Amateur Radio Dealer

New Jersey

RADIOS UNLIMITED
P. O. BOX 347
1760 EASTON AVENUE
SOMERSET, NJ 08873
201-469-4599
New Jersey's Fastest Growing
Amateur Radio Center.

ROUTE ELECTRONICS 46
225 ROUTE 46 WEST
TOTOWA, NJ 07512
201-256-8555
Drake, Swan, DenTron, Hy-Gain,
Cushcraft, Hustler, Larsen, Etc.

WITTIE ELECTRONICS
384 LAKEVIEW AVENUE
CLIFTON, NJ 07011
(201) 546-3000
Same location for 63 years.
Full-line authorized Drake dealer.
We stock most popular brands of
Antennas and Towers.

New Mexico

**PECOS VALLEY
AMATEUR RADIO SUPPLY**
112 W. FIRST STREET
ROSWELL, NM 88201
505 - 623-7388
Now stocking Ten-Tec, Lunar, Icom,
Morsematic, Bencher, Tempo,
Hy-Gain, Avanti and more at low,
low prices. Call for quote.

New York

BARRY ELECTRONICS
512 BROADWAY
NEW YORK, NY 10012
212-925-7000
New York City's Largest Full Service
Ham and Commercial Radio Store.

GRAND CENTRAL RADIO
124 EAST 44 STREET
NEW YORK, NY 10017
212-599-2630
Drake, Kenwood, Yaesu, Atlas,
Ten-Tec, Midland, DenTron,
Hy-Gain, Mosley in stock.

HARRISON RADIO CORP.
20 SMITH STREET
FARMINGDALE, NY 11735
516-293-7990
"Ham Headquarters USA"
since 1925.
Call toll free 800-645-9187.

RADIO WORLD
ONEIDA COUNTY AIRPORT
TERMINAL BLDG.
ORISKANY, NY 13424
Toll Free 800-448-7914
NY { 315-337-2622
Res. { 315-337-0203
New & Used Ham Equipment.
See Warren K2IXN or Bob WA2MSH.

Ohio

UNIVERSAL AMATEUR RADIO, INC.
1280 AIDA DRIVE
COLUMBUS (REYNOLDSBURG)
OH 43068
614-866-4267
Complete Amateur Radio Sales and
Service. All major brands - spacious
store near I-270.

Pennsylvania

**HAMTRONICS, DIV. OF
TREVOSE ELECTRONICS**
4033 BROWNSVILLE ROAD
TREVOSE, PA 19047
215-357-1400
Same Location for 30 Years.

LaRUE ELECTRONICS
1112 GRANDVIEW STREET
SCRANTON, PENNSYLVANIA 18509
717-343-2124
ICOM, Bird, Cushcraft, CDE,
Ham-Keys, VHF Engineering,
Antenna Specialists.

SPECIALTY COMMUNICATIONS
2523 PEACH STREET
ERIE, PA 16502
814-455-7674
Service, Parts, & Experience
For Your Atlas Radio.

Virginia

ELECTRONIC EQUIPMENT BANK
516 MILL ST., N.E.
VIENNA, VA 22180
703-938-3350
Metropolitan D.C.'s One Stop
Amateur Store. Largest
Warehousing of Surplus Electronics.

FREE! RADIO AMATEURS WORLD ATLAS with purchase of famous CALLBOOK MAP LIBRARY!

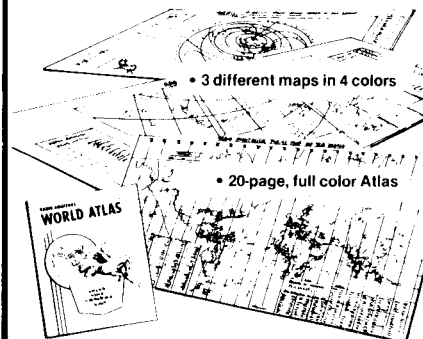

Here's an offer you can't refuse! You receive three, information-packed, Amateur Callbook maps, folded, plus the World Atlas for only \$4.50 plus \$1.50 shipping and handling. If purchased separately, total value of map/atlas offer would be \$7.50 plus shipping. You save \$3.00 and get these invaluable radio amateur aids!

1. **Prefix Map of the World**, folded. World-wide prefixes. Shows 40-zone map on one side, 90-zone map on the other. Size 40" x 28"
2. **Map of North America**, folded. Includes Central America and Caribbean to the Equator. Shows call areas, zone boundaries, prefixes, etc. Size 30" x 25"
3. **Great Circle Chart of World**, folded. Centered on 40°N, 100°W. Shows cities, latitude, longitude, great circle bearings and more! Size 30" x 25"

Plus special FREE bonus!
The Callbook's own **Radio Amateur World Atlas**, FREE with the purchase of the 3 maps. Contains eleven full color maps of the world, looking at things from the radio amateurs point of view.

Callbook Map Library	\$4.50
Shipping	1.50
Total	\$6.00



Special Offer!
**Amateur Radio
Emblem Patch
only \$2.50 prepaid**

Pegasus on blue field, red lettering. 3" wide x 3" high. Great on jackets and caps. Sorry, no call letters.

ORDER TODAY!

Order from your favorite electronics dealer or direct from the publisher. All direct orders add \$1.50 for shipping. Illinois residents add 5% Sales Tax.

RADIO AMATEUR **callbook** INC.
Dept. FN
925 Sherwood Drive
Lake Bluff, ILL 60044



VJ90SSB

POWER-UP FOR ONLY \$79.95

AMPLIFIER ONLY

SPECIAL PACKAGE DEAL

FACTORY DIRECT ONLY

That's right — 90 watts of linear power for 2 meters for only \$79.95. Check out the VJ90SSB Power Chart, and you'll see the real value — 8 watts out for one watt drive, 16 out with two watts drive! Now you can put that new HT to mobile use, for only \$79.95. As a special deal, we've designed a 19dB gain in-line preamp with integrated T/R relay. A \$29.95 value, for only \$20.00 when purchased with the VJ90SSB Amplifier.

But that's not all! We've built a 15 amp (20 amp surge) 13.8VDC power supply just for this combo, the VJ15. When you buy the VJ90SSB and Preamp, we'll sell you this super power supply for only \$79.95. It all adds up to over \$225.00 worth of gear for only \$179.90. Don't wait. Order Today!



VJ15

Each VJ Product component is hand wired and individually tuned for maximum reliability and performance. VJ Products are guaranteed to be free of defects in parts or workmanship for 1 year from the date of purchase. POWER TRANSISTORS ARE EXCLUDED. BUT WARRANTED FOR 90 DAYS. Visa accepted. Immediate shipment guaranteed by VJ Products, Inc.

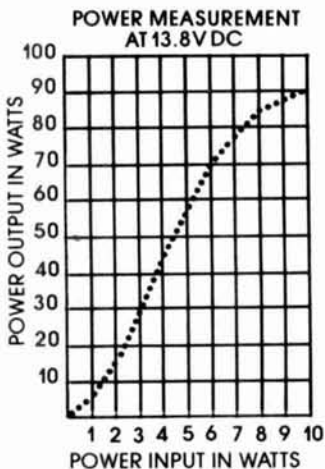

POWER CHART



Please ship: VJ90SSB @ \$79.97 + \$2.00 shipping
 VJ90SSB/Preamp @ \$99.95 + \$3.50 shipping
 VJ15 P/S @ \$79.95 + \$2.50 shipping

Name _____ Call _____
 Street _____
 City _____ State _____ Zip _____
 Send Check, M/O, or Visa # _____ Exp. Date _____

SERVING THE ELECTRONICS INDUSTRY SINCE 1965 V-J Products, Inc. 505 E. Shaw Street, Pasadena, Texas 77506 (713) 477-0134

Factory Direct Only!

THE WORLD'S FIRST

1800 CHANNEL FULLY SYNTHESIZED
COMPACT VHF FM MONITOR

AR-22
FACTORY DIRECT
PRICE \$125.00

This price in U.S. only



- FULL BAND COVERAGE
141.000-149.995 MHZ
5 KHZ Steps by digital switches.
- SLIM SIZE AND LIGHT-WEIGHT.
5 1/4" (H) x 2 1/2" (W) x 1" (D)
7.1 oz with NiCd Battery Pack



- COMMERCIAL BAND TYPE (151-159 MHZ) IS ALSO AVAILABLE.
- CREDIT CARDS/MONEY ORDER OR ANY COMMERCIAL GUARANTEED CHECK...U.P.S. COD

ACE COMMUNICATIONS, INC.
2832-D Walnut Avenue, Tustin, California 92680
Phone (714)544-8281

new COAX SWITCHES

from Barker & Williamson

Model 593

- Single Pole 3 Position with grounding of all unused positions
- Crosstalk (measured at 30 MHz) is -45db between adjacent outlets and 60 db between alternate outlets



Model 594

- 2 Pole 2 Position
- Crosstalk 45db (measured at 30 MHz)



Specifications for both switches

- Power 1 KW-2 KW PEP
- Impedance 50-75 ohms
- VSWR 1.2:1 up to 150 MHz
- Dimensions 1 3/4" high, 5" wide, 3" deep
- Weight 1 lb.
- Mount Wall or desk

Available at your B&W dealer



Barker & Williamson, Inc.
10 Canal St. Bristol, Pa. 19007
Telephone: (215) 788-5581

With the Yaesu FT-480R . . .

TWO METERS COMES ALIVE!



SSB activity is flourishing, repeater activity is at an all-time high, and OSCAR users are breaking records every day. Let the FT-480R step you up to space-age performance on SSB, CW, and FM.

Features

- Coverage of 143.5 - 148.5 MHz (good news for you MARS operators)
- USB, LSB, CW and FM operation are all built-in
- Four channels of memory, with priority channel
- Two VFOs for unusual repeater splits
- Convenient synthesizer steps: 10 Hz, 100 Hz, or 1 kHz per step on SSB/CW, 1 kHz, 20 kHz, or 100 kHz per step on FM
- Scanning control from microphone
- Highly effective noise blanker
- Receiver offset tuning for following Doppler-shifted signals
- SAT switch allows shifting of transmit frequency during OSCAR operation (many rigs cannot QSY on TX)
- 30 watts DC input on FM/CW, 30 watts PEP input on SSB, HI/LOW power selection on FM and CW
- Built-in tone burst generator
- Bright LED signal strength/relative power output level meter
- Easy-to-read fluorescent display of operating frequency and memory channel
- Front panel switch for zeroing synthesizer to convenient step when changing modes from SSB/CW to FM
- Requires 13.8 VDC, negative ground

Available Options:

- FP-80 AC Power Supply
- FTS-64E Synthesized CTCSS/Burst Encoder

Price and specifications subject to change without notice or obligation

Did You Know . . .

Yaesu now has a crystal-controlled 220 MHz FM rig — The FT-127

FLASH!
Also Now Available
NEW FT-680R USB/CW/AM/FM
6 Meter Transceiver

YAESU
The radio.



1080

EIMAC's new high-mu triode/cavity combination. It takes the hassle out of 10 kW VHF transmitter design.

Relax. Now EIMAC offers you the best triode available and a cavity that has been custom designed for it. All you have to do is design them in.

The advantages are impressive. EIMAC's ceramic-metal high-mu triode (3CX10000U7) gives you peak sync power output of 10 kW and a stage gain of 14 dB. That's 2 dB more than with comparable tetrodes.

And there's more. Driving requirements are reduced; screen power supply and screen circuitry are eliminated; and cooling requirements are lessened. The result is ease of maintenance and substantial cost reduction.

There are two EIMAC cavities for your 10 kW combination, the CV-2240 for channels 2-6, and the CV-2250 for channels 7-13. For further information contact Varian, EIMAC Division, 301 Industrial Way, San Carlos, California 94070, (415) 592-1221. Or call any of the more than 30 Varian Electron Device Group Sales Offices throughout the world.

